

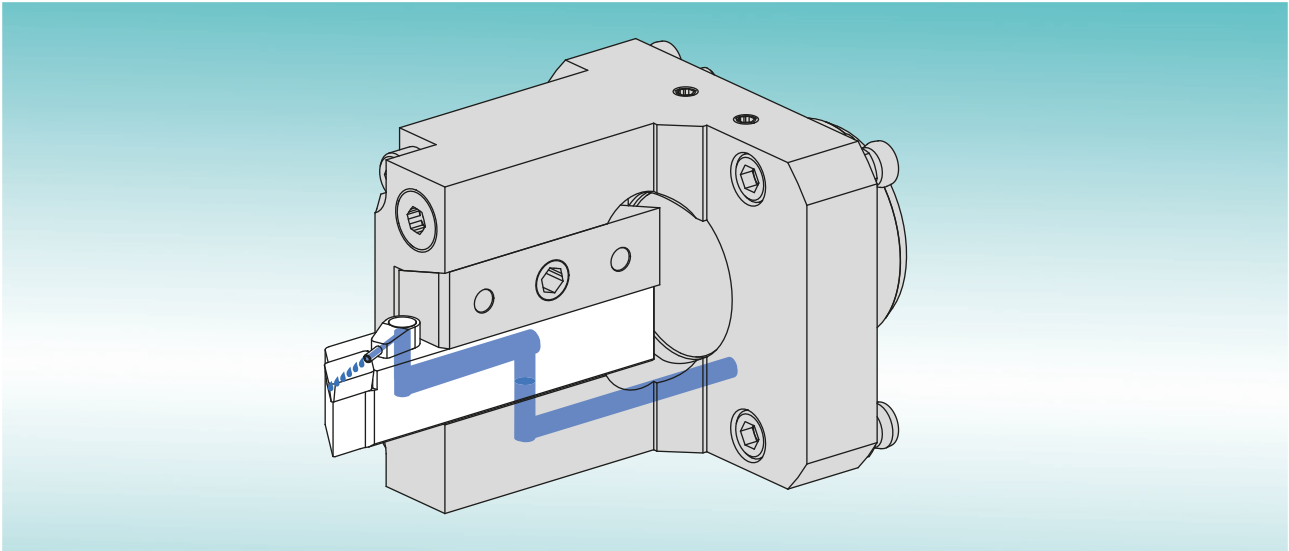

Turning and grooving tool holders with internal cooling lubricant supply

Turning and grooving tool holders with internal cooling lubricant supply



With the new turning and grooving tool holders for cutting tools with internal cooling lubricant supply, you increase process reliability and productivity through:

- improved chip control
- longer service lives
- enhanced surface finish

Significant benefits for grooving and cutting off:

- the cutting edge is reached on deep grooves
- increased process reliability by targeted rinsing off the chips from the groove

Turning and grooving tool holders for cutting tools with internal cooling lubricant supply no longer require any additional coolant pipes. This eliminates the adjusting of coolant pipes and chip accumulations are avoided.

Of course, this solution can be used up to 120 bar depending on the machine. Available for all common INDEX or TRAUB machines.

Please feel free to contact us if you have any further questions +49 711 3191-9854 or visit us online: ixshop.ixworld.com

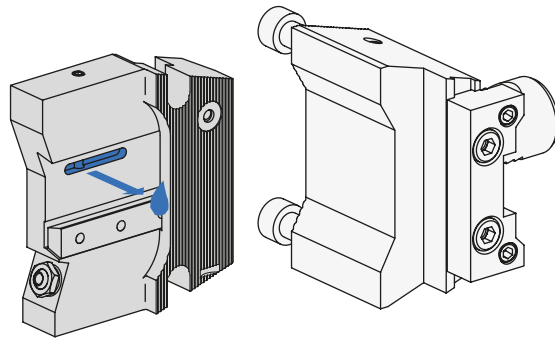

VDI tool holders

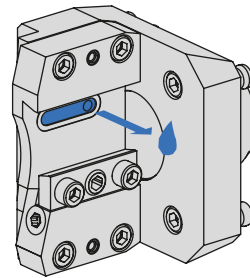

Compact shank tool holders

**Grooving tool holder /
grooving tool holder blocks
with internal cooling lubricant supply**

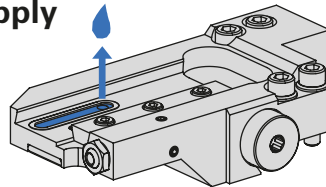

INDEX MS

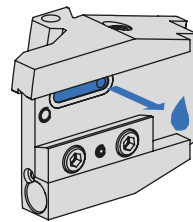

TRAUB TNK/TNL

**Turning tool holder
with internal cooling lubricant supply**

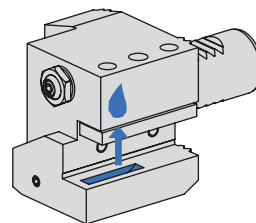

VDI tool holders

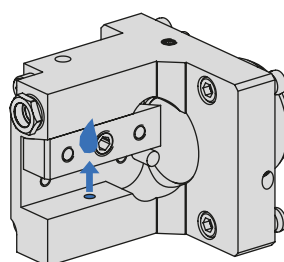

Compact shank tool holders

INDEX

INDEX-Werke GmbH & Co. KG Hahn & Tessky

Plochinger Straße 92
D-73730 Esslingen

Fon +49 711 3191-0
Fax +49 711 3191-587

info@index-werke.de
www.index-werke.de