

# Tool Holder Catalog

**TRAUB TNL 18P**

**TRAUB TNL 18-7**

**TRAUB TNL 18-7B**

**TRAUB TNL 18-9**



# Tool Holder Catalog

**TRAUB TNL 18P**

**TRAUB TNL 18-7**

**TRAUB TNL 18-7B**

Technical information

Usage information

## **Disclaimer**

The illustrations in this documents may deviate from the delivered product. We reserve the right to make changes due to errors or based on technical advances.

## **Abbreviations used in the catalog:**

EC = external cooling lubricant supply

approx.= approximately

D = diameter

max = maximum

min = minimum

IC = internal cooling lubricant supply

MT = Morse taper

R = radius

s = wrench size

ST = steep taper

SQ = square

## **A word on copyright**

This document is proprietary and was originally written in German. Its reproduction and distribution in whole or in individual parts without permission of the copyright owner is prohibited and will be prosecuted under criminal or civil law. All rights reserved, including for translation.

© Copyright by INDEX-Werke GmbH & Co. KG Esslingen 2014

© Copyright by TRAUB Drehmaschinen GmbH & Co. KG Reichenbach 2014

---

Table of contents .....	0
Technical Information TRAUB TNL 18 .....	1
Usage information TRAUB TNL 18.....	2
Stationary tool holder, turret head.....	3
Live tool holder, turret head.....	4
Stationary tool holder, rear end machining unit .....	5
Live tool holder, rear end machining unit.....	6
Accessories – Quick-change inserts.....	7
Accessories – TRAUB TNL 18 .....	8
Product information.....	9

For accessories for tool holders visit <http://infoshop.index-werke.de/>



## **Table of Contents**





	<b>Catalog page</b>
<b>Warranty</b>	<b>1-2</b>
<b>Information on wear parts</b>	
<b>Inspection of live tool holders and guide bushings</b>	
<hr/>	
<b>Coolant supply</b>	<b>1-3</b>
<b>Cooling lubricant filtering</b>	
<b>Cleaning</b>	
<hr/>	
<b>Speed ratio specifications for tool holders</b>	<b>1-4</b>
<hr/>	
<b>Direction-of-rotation information of tool holders</b>	<b>1-5</b>
<hr/>	
<b>Notes on how to use the chart when using tool holders</b>	<b>1-6</b>
<hr/>	
<b>Tool turrets</b>	<b>1-7</b>
<b>Swivel drive as rotary axis</b>	
<b>Turret head</b>	
<b>Live tool holder, turret head</b>	
<hr/>	
<b>Tool holder system on tool turret</b>	<b>1-8</b>

**Catalog page**

---

**Attaching/detaching the tool holders  
to/from the tool turret** **1-9**

---

**Tool drive on the tool turret** **1-10**  
**Dry run for live tool holders**

---

**Cleaning the tool drive** **1-11**

---

**Tooling system on the rear end machining unit** **1-12**  
**Tool mounting - rear end machining unit**  
**Tool clamping - rear end machining unit**

---

**Tool drive - rear end machining unit** **1-13**

---

**External cooling lubricant supply** **1-14**  
**Internal cooling lubricant supply**

---

**Replacing cooling lubricant transfer valve** **1-15**

---

---

**Catalog page**

**Blanking plug**

**1-16**

---

**WFB interface,**

**1-17**

**Mounting**  
**Cleaning and care**  
**Tightening torques**

---

		Catalog page
	<b>Modular system of TRAUB TNL 18P, TNL 18-7, TNL 18-7B</b>	<b>2-2</b>
<b>901339</b>	<b>Work area TRAUB TNL 18P</b> Fixed headstock turning	<b>2-3</b>
<b>901339</b>	<b>Work area TRAUB TNL 18P</b> Sliding headstock turning	<b>2-4</b>
<b>901339</b>	<b>Work area TRAUB TNL 18P</b>	<b>2-5</b>
<b>901320</b>	<b>Work area TRAUB TNL 18-7</b> Fixed headstock turning	<b>2-6</b>
<b>901320</b>	<b>Work area TRAUB TNL 18-7</b> Sliding headstock turning	<b>2-7</b>
<b>901320</b>	<b>Work area TRAUB TNL 18-7</b>	<b>2-8</b>

		Catalog page
<b>901990</b>	<b>Work area TRAUB TNL 18-7B</b> B-axis 90° Fixed headstock turning	<b>2-9</b>
<b>901990</b>	<b>Work area TRAUB TNL 18-7B</b> B-axis 90° Sliding headstock turning	<b>2-10</b>
<b>901990</b>	<b>Work area TRAUB TNL 18-7B</b> B-axis -45°, machining to main spindle Sliding headstock turning	<b>2-11</b>
<b>901990</b>	<b>Work area TRAUB TNL 18-7B</b> B-axis -90°, machining to main spindle Sliding headstock turning	<b>2-12</b>
<b>901990</b>	<b>Work area TRAUB TNL 18-7B</b> B-axis 5° / -95°, machining to main spindle Sliding headstock turning	<b>2-13</b>
<b>901990</b>	<b>Work area TRAUB TNL 18-7B</b> B-axis -45°, machining to counter spindle Sliding headstock turning	<b>2-14</b>
<b>901990</b>	<b>Work area TRAUB TNL 18-7B</b>	<b>2-15</b>

	Catalog page
<b>901320</b> <b>Rear end machining unit</b> 3 stationary stations T16, T17, T18 for simultaneous machining	<b>2-16</b>
<b>901320</b> <b>Rear end machining unit</b> Station T15 for flushing	<b>2-17</b>
<b>901320</b> <b>Rear end machining unit</b> 4 stations T11, T12, T13, T14 for non-simultaneous machining  Stations T12, T13, T14 can be equipped with live tool holders	<b>2-18</b>
	<b>2-19</b>
	<b>2-20</b>
<b>Performance diagram</b> Live tools Counter spindle, lower tool turret Speed range 0-12000 rpm	<b>2-21</b>
<b>Performance diagram</b> Live tools Top tool turret Speed range 0-12000 rpm	<b>2-22</b>

Catalog page  
2-23

---

**Performance diagram**

Live tools  
Rear end machining unit, station T13  
Speed range 0-4000 rpm

---

2-24

**Performance diagram**

Live tools  
rear end machining unit, stations T12, T14  
Speed range 0-10000 rpm

---

2-25

**Quick-Change Insert WFB**

Operating Instructions  
2-piece shrink fit chuck

---





## **Technical Information**

**TRAUB TNL 18P**

**TRAUB TNL 18-7**

**TRAUB TNL 18-7B**

## Warranty



When using tool holders that have not been set, checked and labeled accordingly by INDEX TRAUB, warranty is not applicable to the tool drive.

## Information on wear parts

Tool holders and guide bushings are wear parts that require correct handling.

In order to ensure a long service life, compressed air or cooling lubricant must not enter the gap seals of the holders or of the guide bushings.

## Inspection of live tool holders and guide bushings



Tool holders and guide bushings must be inspected at regular intervals (at least twice a year) for smooth running and play.



The drive pinion and drive clutch of the live tool holders must be subjected to a visual inspection for damage or wear.

If one of the above-mentioned defects is detected during the inspection of the tool holders or guide bushings, they must be returned immediately for preventive maintenance or repair to the following address:

TRAUB Drehmaschinen GmbH & Co. KG  
Hauffstrasse 4  
D-73262 Reichenbach, Germany  
Phone +49 (0) 7153 502-554  
werkzeughalter@traub.de

### Tool holders with cooling lubricant supply



Tool holders marked with this symbol must be operated with cooling lubricant (no dry run permitted).



Tool holders marked with this symbol must be operated with cooling lubricant when converting from external cooling lubricant supply to internal cooling lubricant supply. Observe dry run capability of IC attachment!

### Cooling lubricant filtering

When using live tool holders with internal cooling lubricant supply, it is necessary to use a cooling lubricant filter system with a retained particle size  $\leq 50 \mu$ .

### Cleaning live tool holders

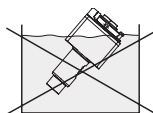

Live tool holders must never be immersed in cleaning fluid since mixing the cleaning fluid with the bearing grease will reduce the service life of the tool holders.

### Speed ratio specifications on tool holders

The value to be programmed is specified in the documentation and on the live tool holders  
( = the input in the NC program).

$$n_{\text{prog}} = n_{\text{TOOL}} \times i$$

$n_{\text{TOOL}}$  = speed at cutting tool edge

$n_{\text{PROG}}$  = speed to be programmed

$i$  = speed ratio in the tool holder

This means: the speed increase or speed reduction is not specified as a fraction but as **a number**.

This gives speed **increase** ratios as numbers **smaller than 1**.

Example:  $i = 0.333$  (corresponds to  $i = 1:3$ )  
 $i = 0.676$  (corresponds to  $i = 1:1.48$ )

Speed **reduction** ratios as numbers **greater than 1**

Example:  $i = 2$  (corresponds to  $i = 2:1$ )  
 $i = 1.333$  (corresponds to  $i = 4:3$ )



The tool holder speed ratio is engraved in TRAUB TNL tool holders.



Tool holders for the rear end machining unit can have a second speed ratio engraved in individual cases. Please consider the larger, integer speed ratio indicated in such a case.

### Direction of rotation specification

Definition of the viewing direction

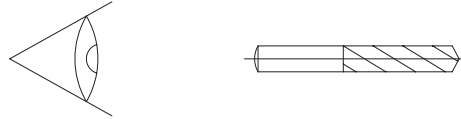

The viewing direction for determining the direction of rotation is always from the rear (i.e., from the drive direction) towards the shaft.



On the machine side, the direction of rotation has been set by parameters such that M03 always denotes clockwise rotation and M04 counter-clockwise run at the interface of the drive pinion of the tool holder.

The direction of rotation given on the holder therefore refers to a "change in direction within the holder".

M03 and M04 are machine functions to be programmed.

The  and  arrows indicate the direction of rotation of the cutting edges.

This means:

#### No reversal of direction of rotation



- When the holder drive shaft has the **same** direction of rotation as the tool cutting edge, the clockwise direction of run must be specified by M03 (clockwise rotation). Accordingly, counter-clockwise run must be specified by M04.



#### Reversal of direction of rotation

- When the holder drive shaft has the **opposite** direction of rotation as the tool cutting edge, the clockwise direction of rotation must be specified by M04. Accordingly, counter-clockwise run must be specified by M03.

Example

#### No reversal of direction of rotation

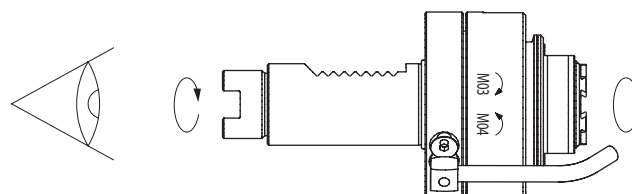

**Notes on how to use the chart  
when using tool holders**

The chart relates to the output speed **n** of the tool unit. The tool speed can be read directly from the chart only if the internal speed ratio **i** in the tool holder is 1:1.

For tool holders (e.g., VDI holders) with an internal speed ratio  $i \neq 1$ , the output speed **n** of the tool unit to be programmed must be calculated from the required tool speed and the speed ratio **i**. Afterwards, the actual powers or torques can be read off or determined.

Example (at 100% duty cycle):

<b>live tool unit, tool speed <math>n_{\text{Tool}} = 1000 \text{ rpm}</math></b>	
Internal speed ratio $i$ of the tool holder	$i = 4$
Programmed speed $n_{\text{prog}}$ for the drive of the unit	$n_{\text{prog}} = n_{\text{Tool}} \times i =$ $1000 \text{ rpm} \times 4 = 4000 \text{ rpm}$
Torque $M_{\text{Tool}}$ at the output of the tool holder	Read-out $M_d$ at speed $n_{\text{prog}} = 4000 \text{ rpm} = 1.6 \text{ Nm}$ $M_d = M_{\text{Tool}} : i$ Formula changed: $M_{\text{Tool}} = M_d \times i = 1.6 \text{ Nm} \times 4 = 6.4 \text{ Nm}$
Power $P$ at the output of the tool holder $\approx$ Power $P$ at the output of the setup	Read-out at 4000 rpm $\rightarrow P = 0.67 \text{ kW}$ calculated: $P = 2 \times \pi \times n_{\text{prog}} \times M_d$ $P = \frac{2 \times \pi \times 4000 \times 1.6 \text{ Nm}}{60 \times 1000} = 0.67 \text{ kW}$

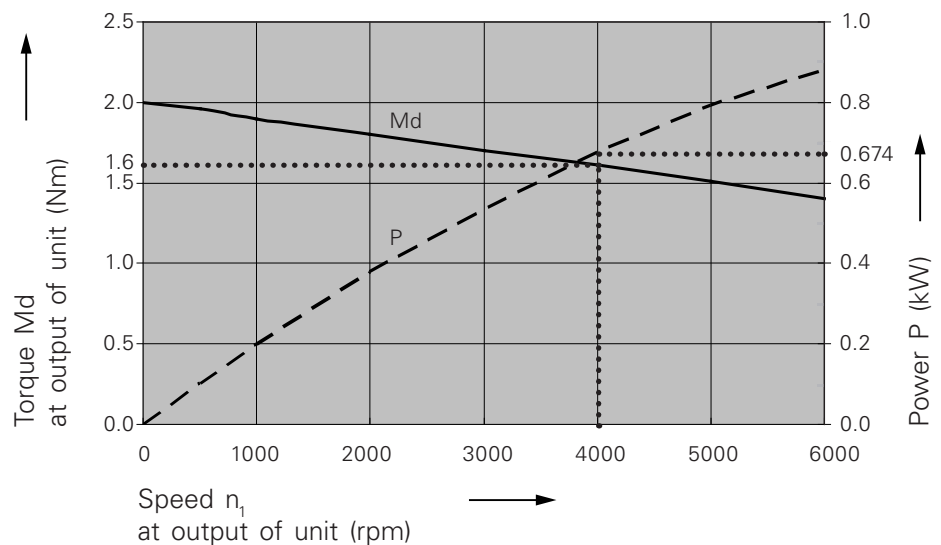

The speed ratio and the technical data of each tool holder are indicated on the next pages.

### Tool turrets

The TNL 18P, TNL 18-7 is equipped with 2 tool turrets: an upper tool turret and a counter spindle with a tool turret. The tool turrets consist of the swivel drive, turret head, tool drive, and axis drives.

For the TNL 18-7B, the upper tool turret is additionally equipped with a rotation axis (B axis).

### Swivel Drive as Rotary Axis

The tool turrets are equipped with a rotary axis. It consists of a cycloidal gearbox (eccentric gearbox) in which the torque is transmitted via curved disks.

This allows high impact loads on the drive (up to 500%), low-wear operation, and low friction losses.

The gearbox is not self-locking. Therefore, the turret head is connected directly with a measuring system that reports the exact position and compensates the cutting forces. This allows top precision turning and milling operations.

### Turret head

Each turret head has 8 tool stations for stationary and live tool holders. All stations are equipped with a cooling lubricant transfer unit. The tool stations 1 and 7 on the upper turret are equipped with an additional fluid transfer station. It can be used either as a sealing air port or as a high-pressure port for cooling lubricant. In this case, the appropriate tool holder and the valves must be available.

The turret heads have fixing inclines for the fixing pins of the tool holders on both sides along their circumference.

### Live tool holder, turret head



When using live tool holders in the turret head, only tool holders with a spur gear with 18 teeth may be used.

When using live tool holders with a different number of teeth, such as TRAUB TNL 32 with 23 teeth, the tool drive will be destroyed.

### Tool holder system on tool turret

The tool holder system is a TRAUB compact shank.

The turret head has a locally hardened fixing incline on both sides along its circumference.

When the tool holder is inserted into the turret head, the tool holder aligns itself automatically with the fixing inclines by means of the fixing pins. The tool holders are fastened to the face of the stations using cylinder head screws.

Most of the tool holders have elastic fixing pins. The elasticity of the fixing pins compensates the width tolerance of the turret head, and the turret head is not damaged in case of a collision.

The fixing pins are arranged eccentrically and are adjusted to their exact positions and sealed by TRAUB.



The customer may not manipulate the adjusted and sealed fixing pins of the tool holders.

The fixing pins can be replaced and readjusted by the manufacturer, e.g., after a collision.

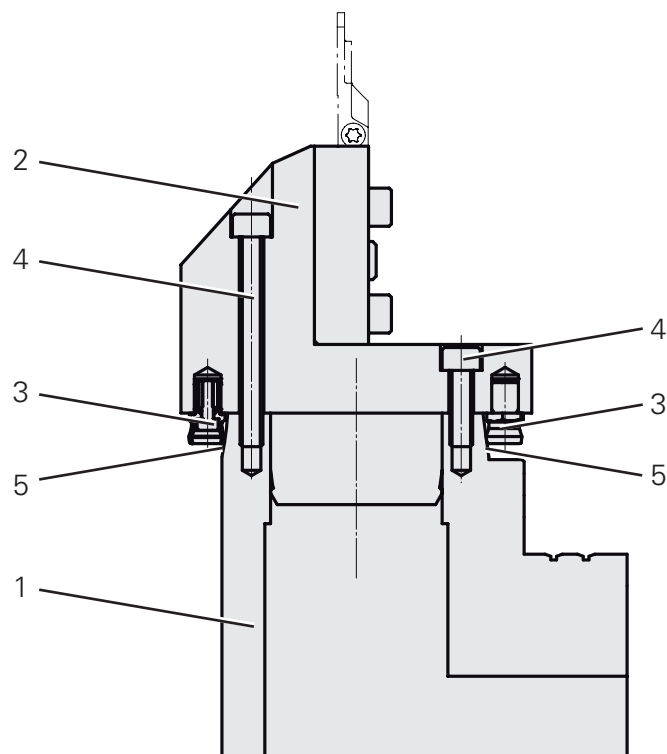

- 1 Turret head
- 2 Tool holder
- 3 Fixing pin
- 4 Cylinder head screws
- 5 Fixing incline



### Attaching/Detaching the Tool Holders to/from the Tool Turret

Swivel the turret head into the required position.  
Carefully remove chips and dirt from the tool holder (or the blanking plug) to be replaced and its surrounding area using a cleaning gun.



Chips and dirt must not enter into the inside of the turret head when tool holders are being replaced.

Clean the removed tool holder and tool receptacle.

Check that the proper mounting screws have been installed on the replacement tool holder. The mounting screws should not protrude more than 12 mm from the tool holder.

Clean and install the tool holder.

For live tool holders, the spindle must be slightly moved so that the drive gear can be pushed into crown wheel.

Tighten mounting screws. Tightening torque  $M_a=14$  Nm.

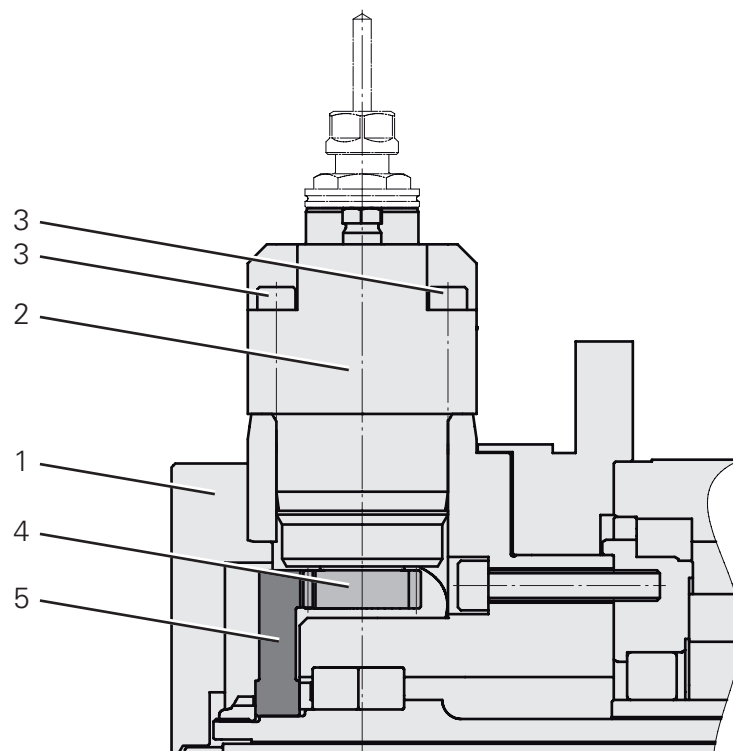

- 1 Turret head
- 2 Tool holder
- 3 Mounting screws
- 4 Drive gear
- 5 Crown wheel

### **Tool Drive on the Tool Turret**

All 8 tool stations on the upper turret and all 7 tool stations on the lower turret can be live.

The tool drive is designed as an overall drive consisting essentially of an AC motor, a drive shaft with a crown wheel, and a controller.

The tool drive's AC motor is designed for heavy duty cutting at low speeds and high torque.

For higher speeds at which lower torques are required, the transmission occurs inside the tool holders.

The counter spindle with a tool turret is live by the same motor as for the tool drive, and it is programmed that way.

The tool turret can be swiveled with the H axis while the tool drive is running.

Thanks to the overall drive, the drive shaft need not be disengaged/engaged from/with the tool holders and accelerated/decelerated.

This makes it possible to swivel the turret head with the H axis while the drive is running.

Depending on the direction of swivel or rotation, the speed is shortly increased or decreased when swiveling the turret.

When swiveling from station to station, the tool drive should not be operated at maximum speed in order to limit the load on the tool holders.

The drive pinion speed can be programmed in a range of 0 to 12,000 rpm via the AC-controlled 3-phase motor.

### **Dry Run for Live Tool Holders**

During setup and automatic mode, make sure that the tooling holder's sealing point at the cooling lubricant transfer is always wet with cooling lubricant.

Tool holders may be operated without cooling lubricant during setup only for a short time. During this time, the leakage of the adding valves and the reserves in the supply line are used for lubrication.

For the rear end machining unit, all tool holders are live simultaneously by the overall drive. This means that unused tool holders must also be supplied with cooling lubricant for a short time.

Therefore, all unused live tool holders should be removed and the corresponding tool receptacle should be closed with blanking plugs.

### Cleaning the tool drive

On the upper and lower tool turrets



When cleaning the tool drive inside the turret head, the flange must not be removed, because otherwise the machine needs to be readjusted.

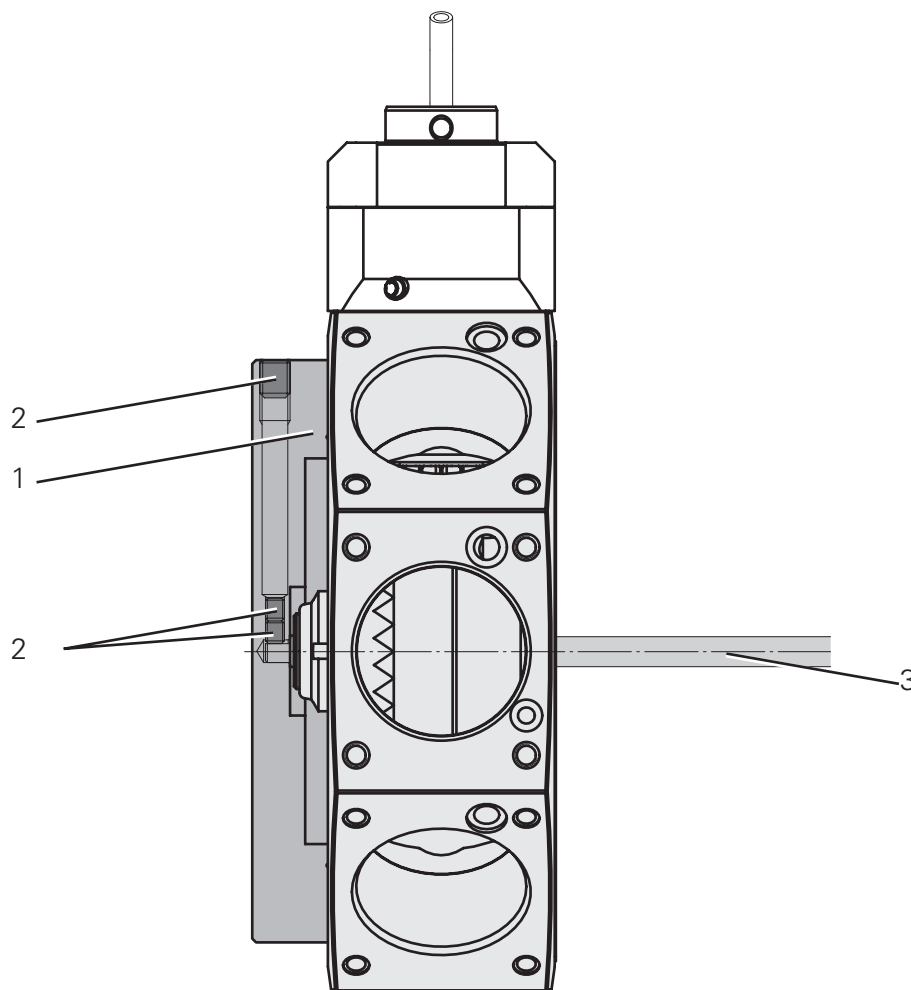

- 1 Flange
- 2 Sealed screw
- 3 Measuring bar

### Tooling system on the rear end machining unit

The rear end machining unit consists of a stationary body with 7 different tool receptacles of D36 mm and one tool flushing hole.

### Tool mounting - rear end machining unit

7 tool holders can be used on the rear end machining unit, 3 of which are rotating.

Each tool receptacle has an oval pin that serves as anti-twist lock and for the supply with cooling lubricant.

The tool holders are clamped via the clamping bolt and clamping wedge.

The tool holders have an insertion groove on their shanks to avoid tilting of the tools when inserting them into the tool mounting.

The max. tightening torque for the clamping bolt is 7-8 Nm.

### Tool clamping - rear end machining unit

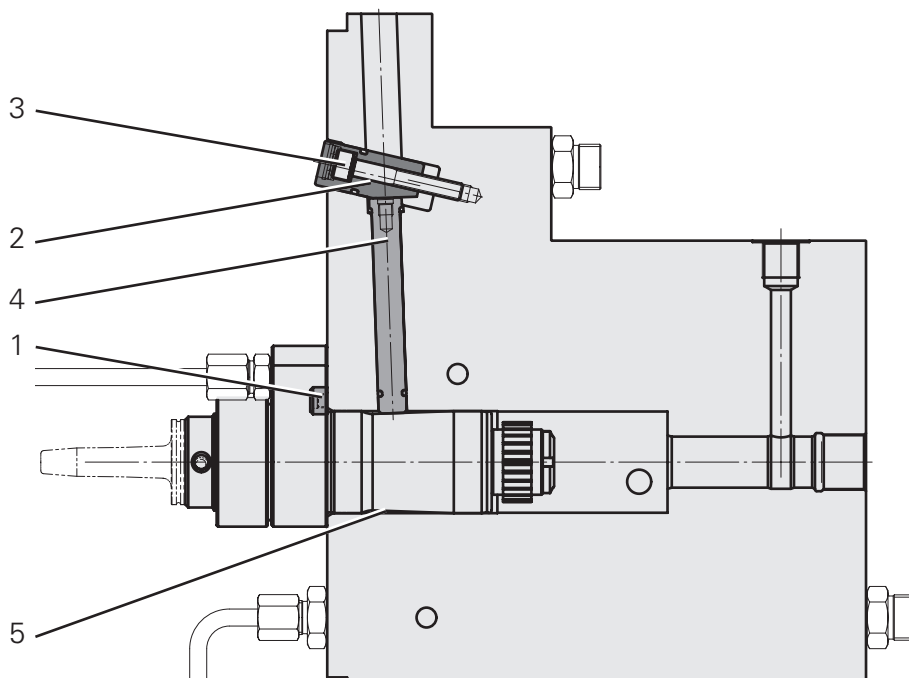

- 1 Oval pre-centering pin with coolant transfer
- 2 Clamping taper
- 3 Clamping screw
- 4 Clamping pin
- 5 2° clamping incline on shank

**Tool drive - rear end machining unit**

The tool drive is available for stations T12, T13 and T14.

The drive coupling is a combined gear with internal and external serration where the internal serration serves as the coupling.

The drive pinion is lubricated by the machine's central lubrication system.

The tool drive motor is an AC motor having a lower speed and higher torque for heavy duty cutting in the lower speed range.

For higher speeds at which lower torques are required, the transmission occurs via the external gear.

This makes the tool drive an overall drive.

**T12 and T14 Driven by external serration**

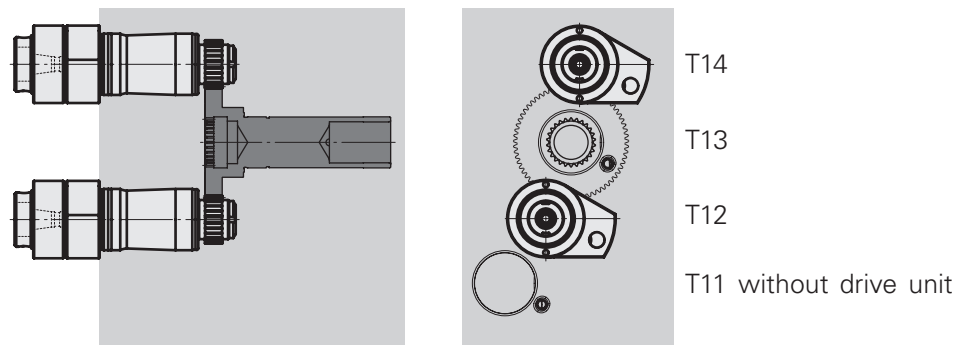

Stations T12 and T14 are live via the external serration. The tool holder runs 2.5 times faster in this case.

At the same time, the direction of rotation is reversed at the drive shaft. The transmission ratio for the same tool holder is  $i=0.4$ .

**T13 Driven by internal serration**

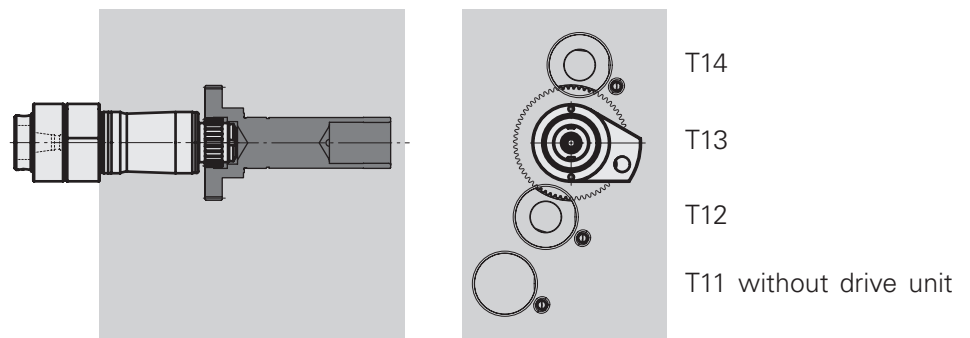

For station T13, the tool holder is live by the drive motor via the internal serration,  $i=1$ .



The indicated pressures are examples and may vary depending on machine equipment

### External cooling lubricant supply

The external cooling lubricant supply (EC), in its simplest design, occurs via the pin in the tool receptacle. The flexible injection tube is part of the tool holder and can be designed as appropriate for the workpieces and as required.

Pressure for fixed / live tools up to 8 bar

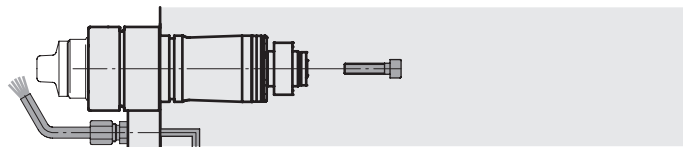

### Internal Cooling lubricant supply

The stations T12, T14, T16 and T17 can optionally be equipped with internal cooling lubricant supply (IC).

For the internal cooling lubricant supply option, a cooling lubricant transfer valve is installed in the rear end machining unit. This valve prevents unintended cooling lubricant leakage in case of a programming error and no rotary admission is installed.

When cutting with an internal cooling lubricant system (IC), the tool holders must be converted for the cooling lubricant supply:

Pressure for fixed tools up to 120 bar

Pressure for live tools up to 30 bar

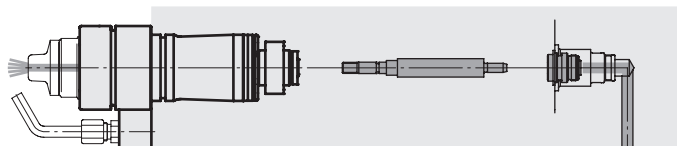

Pressure for live tools up to 120 bar

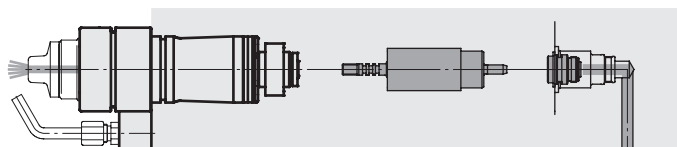

### Replacing the cooling lubricant transfer valve

The seal sets are subjected to natural wear and can be replaced using a socket key and an auxiliary bar. The auxiliary bar is used to hold the valve insert.



The socket key and the auxiliary bar are included in the machine accessories.



During replacement or maintenance of the valve insert, take care that the valve insert does not fall into the gear-box, because this would require very time-consuming dismantling. The auxiliary bar must be used for the replacement.

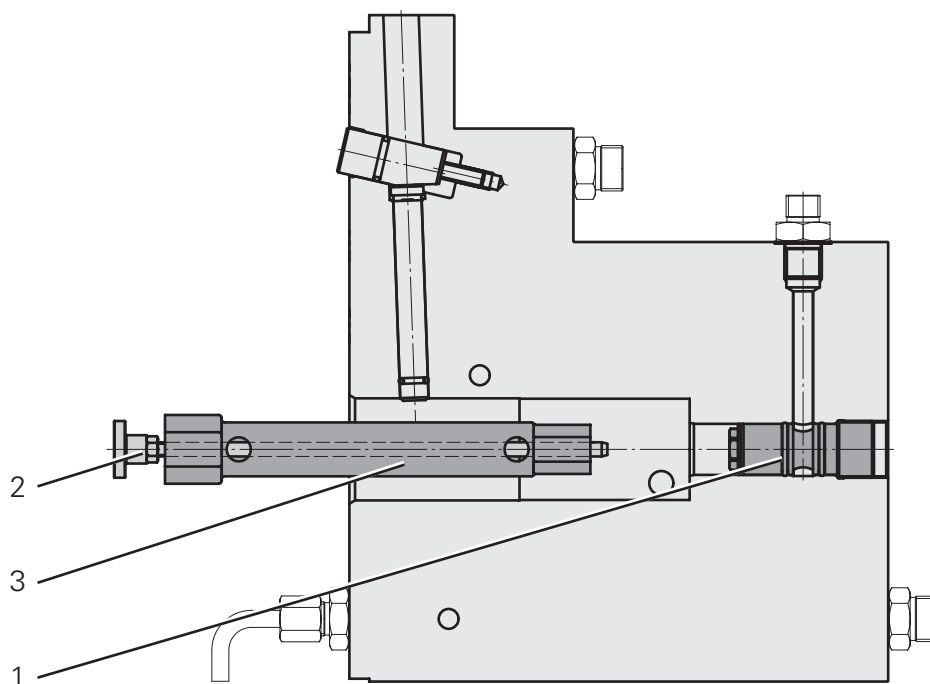

- 1 Sealing inserts
- 2 Auxiliary bar
- 3 Socket wrench

### Blanking plug



The machine may be operated only when all unused tool stations are closed with blanking plugs.



The blanking plugs are not included in the delivery and must be ordered separately.

on the tool turret

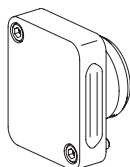

on the rear end machining unit

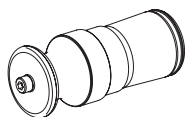



### **WFB Interface, Mounting**

First tighten a threaded taper pin by loosening and retightening it 1-2 times. This results in optimum positioning of the components. Now tighten the second threaded taper pin (in the same way as above). For the recommended torques, please see the table below.

### **WFB interface, service and maintenance**

The surfaces of the faces, taper bore and tapers must be cleaned and covered with an oil lubricating film. For best fastening results and to ensure that the threaded taper pins can easily be loosened, it is recommended to apply Molykote 1000 or a similar hot screw compound to the threaded taper pins.

### **WFB interface, tightening torques**

Recommended tightening torques		
Size	Threaded taper pin	Tightening torque
WFB 20-12	M6x1	4 Nm
WFB 24-16	M8x1	10 Nm
WFB 32-20	M10x1	20 Nm
WFB 40-25	M12x1	25 Nm
WFB 50-32	M14x1	30 Nm

Recommended tightening torques when using mandrel gauges		
Size	Threaded taper pin	Tightening torque
WFB 20-12	M6x1	5 Nm
WFB 24-16	M8x1	5 Nm
WFB 32-20	M10x1	10 Nm
WFB 40-25	M12x1	10 Nm
WFB 50-32	M14x1	15 Nm



## **Usage Information**

**TRAUB TNL 18P**

**TRAUB TNL 18-7**

**TRAUB TNL 18-7B**

**Modular system of TRAUB TNL 18P, TNL 18-7, TNL 18-7B**

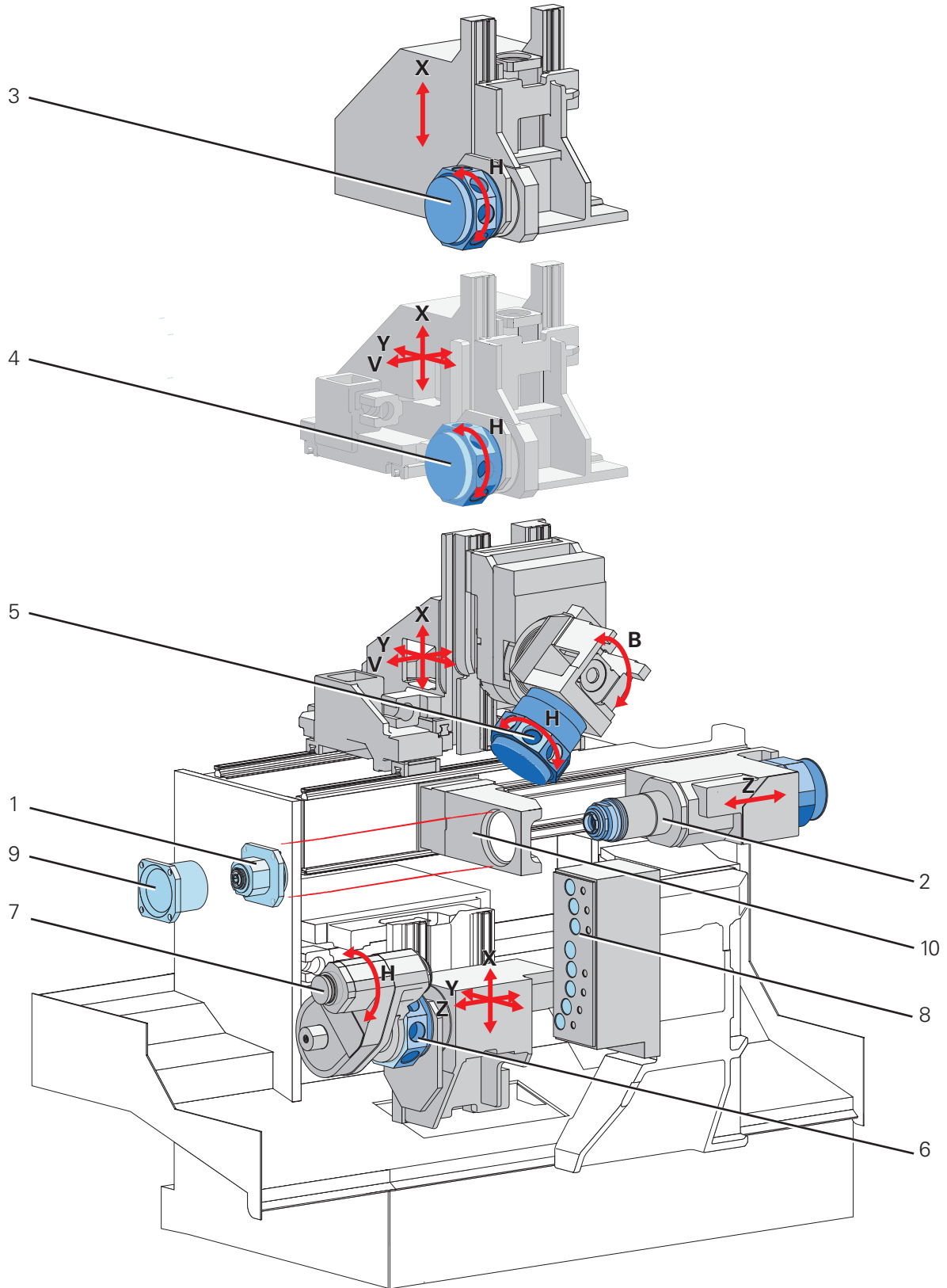

- 1 Guide bushing unit
- 2 Main spindle - Z
- 3 Upper tool turret - XH
- 4 Upper tool turret - XYVH
- 5 Upper tool turret - XYVHB

- 6 Lower tool turret - XYZH
- 7 Counter spindle on tool turret
- 8 Rear end machining unit - 7x
- 9 Guide bushing
- 10 Guide bushing carrier

**Work area TRAUB TNL 18P**

Fixed headstock turning

- ⊕ T = tool holder zero
- ⊕ B = reference point
- ⊕ R = reference point
- ⊕ M = machine zero

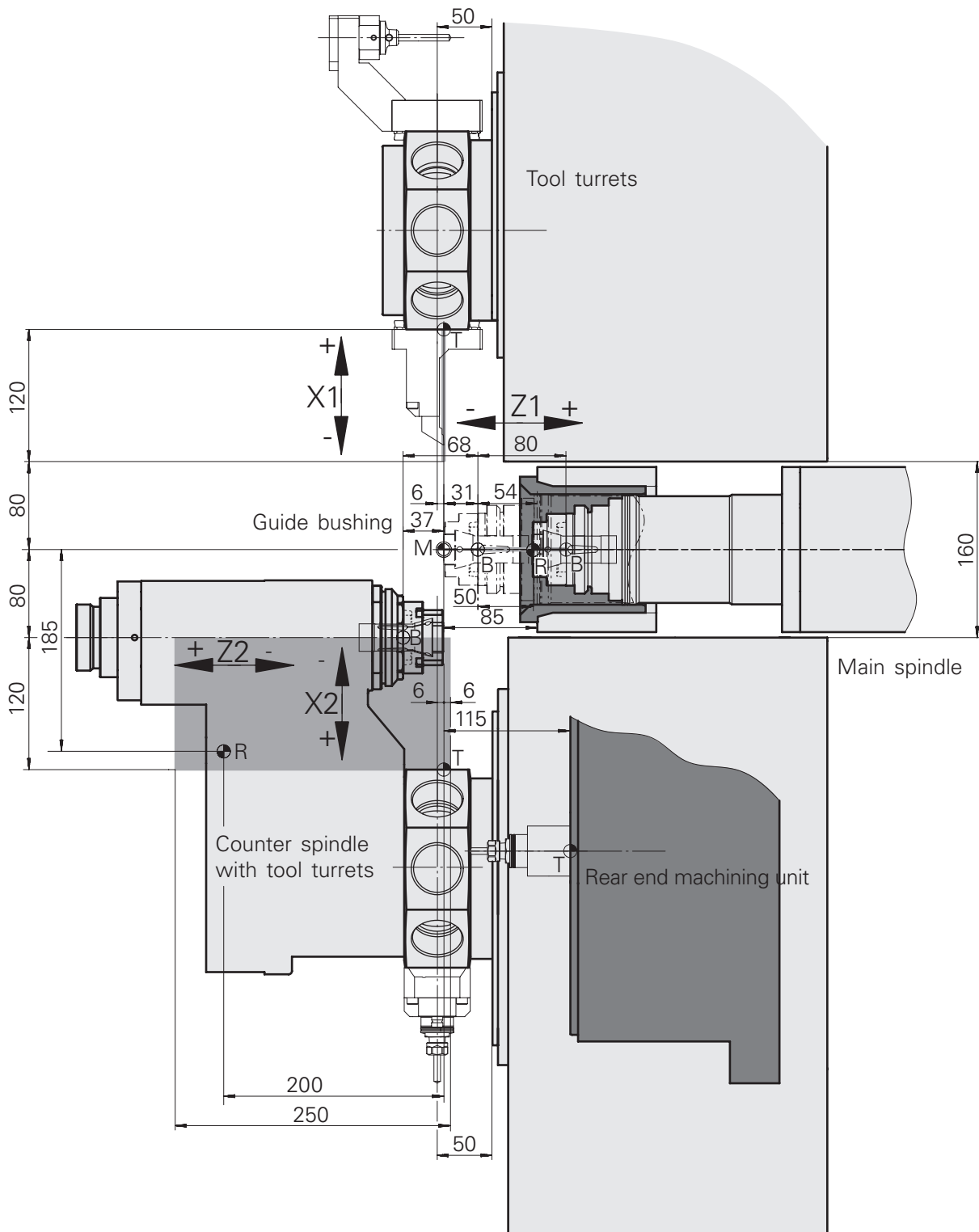

Work area TRAUB TNL 18P

Sliding headstock turning

- ⊕ T = tool holder zero
- ⊕ B = reference point
- ⊕ M = machine zero

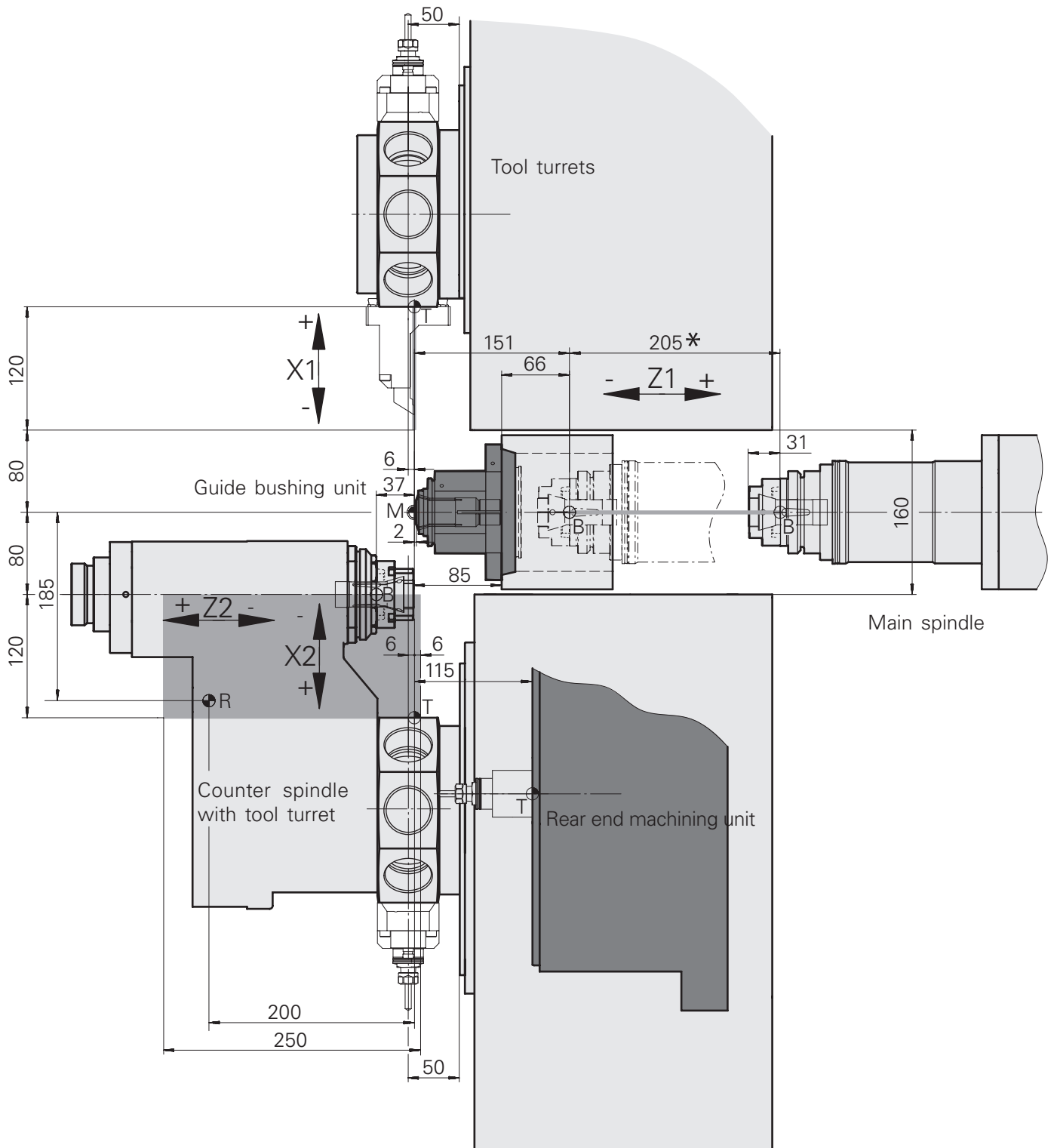

\*The stroke depends on the clamping device (Z1)

Work area TRAUB TNL 18P

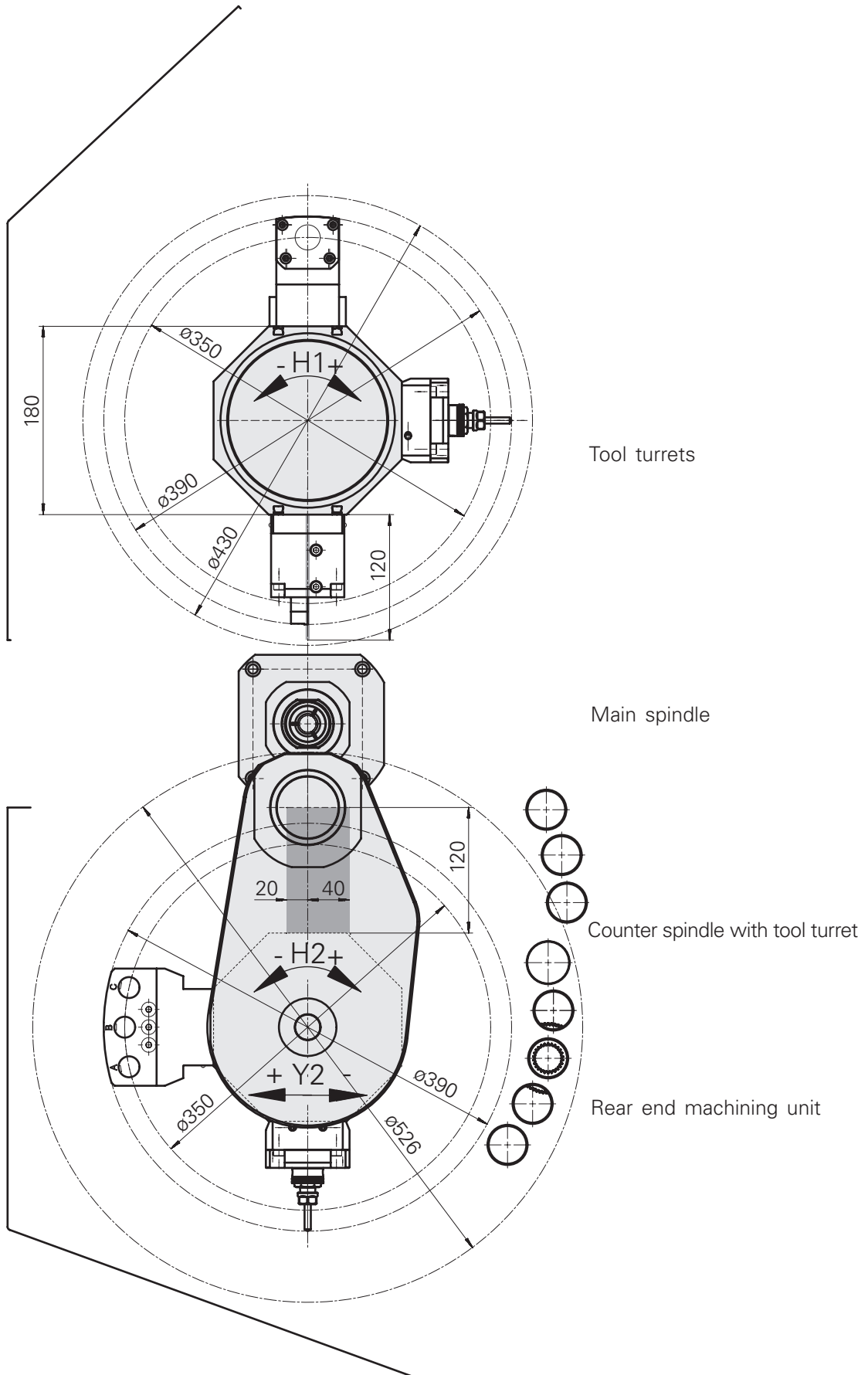

**Work area TRAUB TNL 18-7**

Fixed headstock turning

- ⊕ T = tool holder zero
- ⊕ B = reference point
- ⊕ R = reference point
- ⊕ M = machine zero

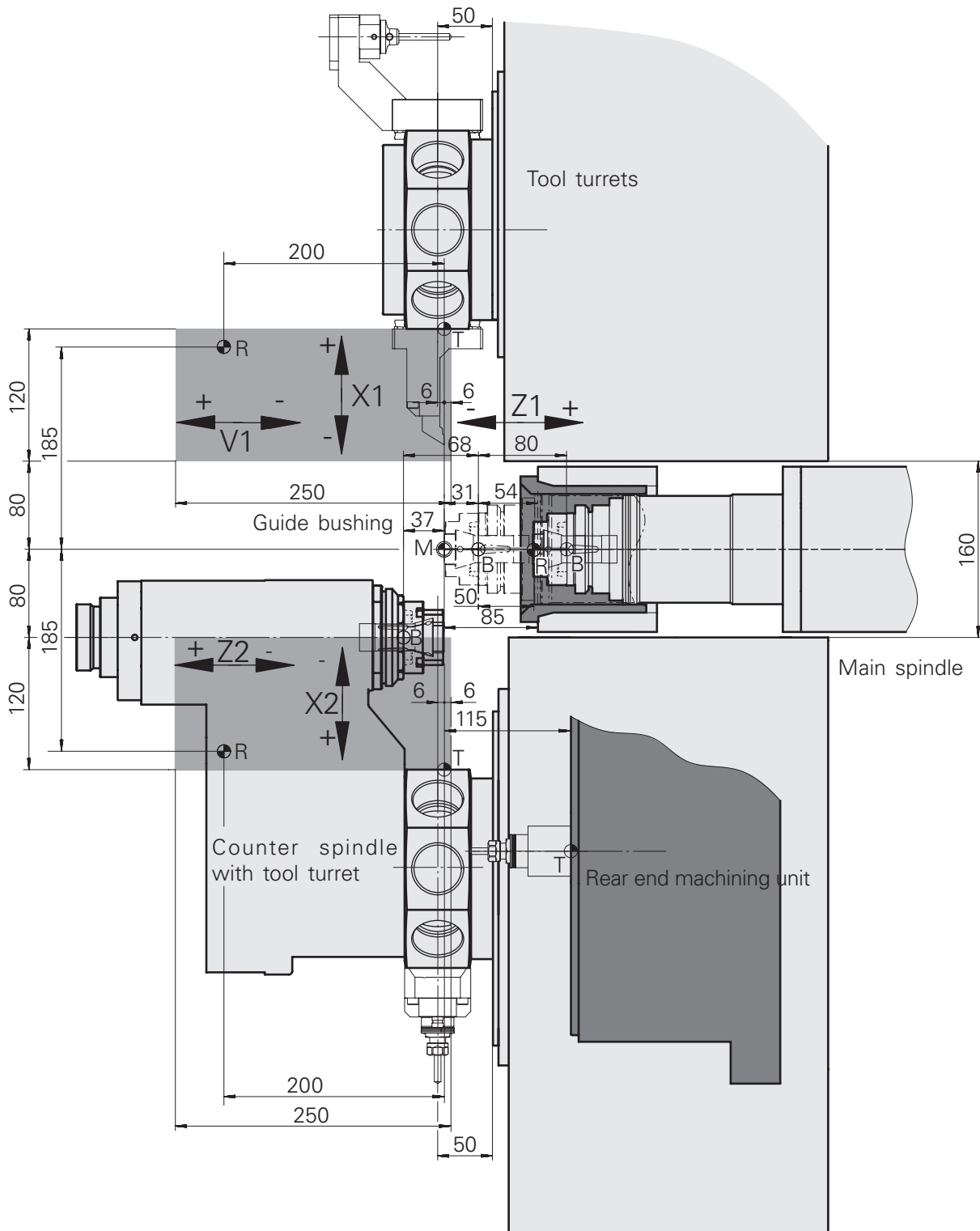



Work area TRAUB TNL 18-7

Sliding headstock turning

- ⊕ T = tool holder zero
- ⊕ B = reference point
- ⊕ M = machine zero

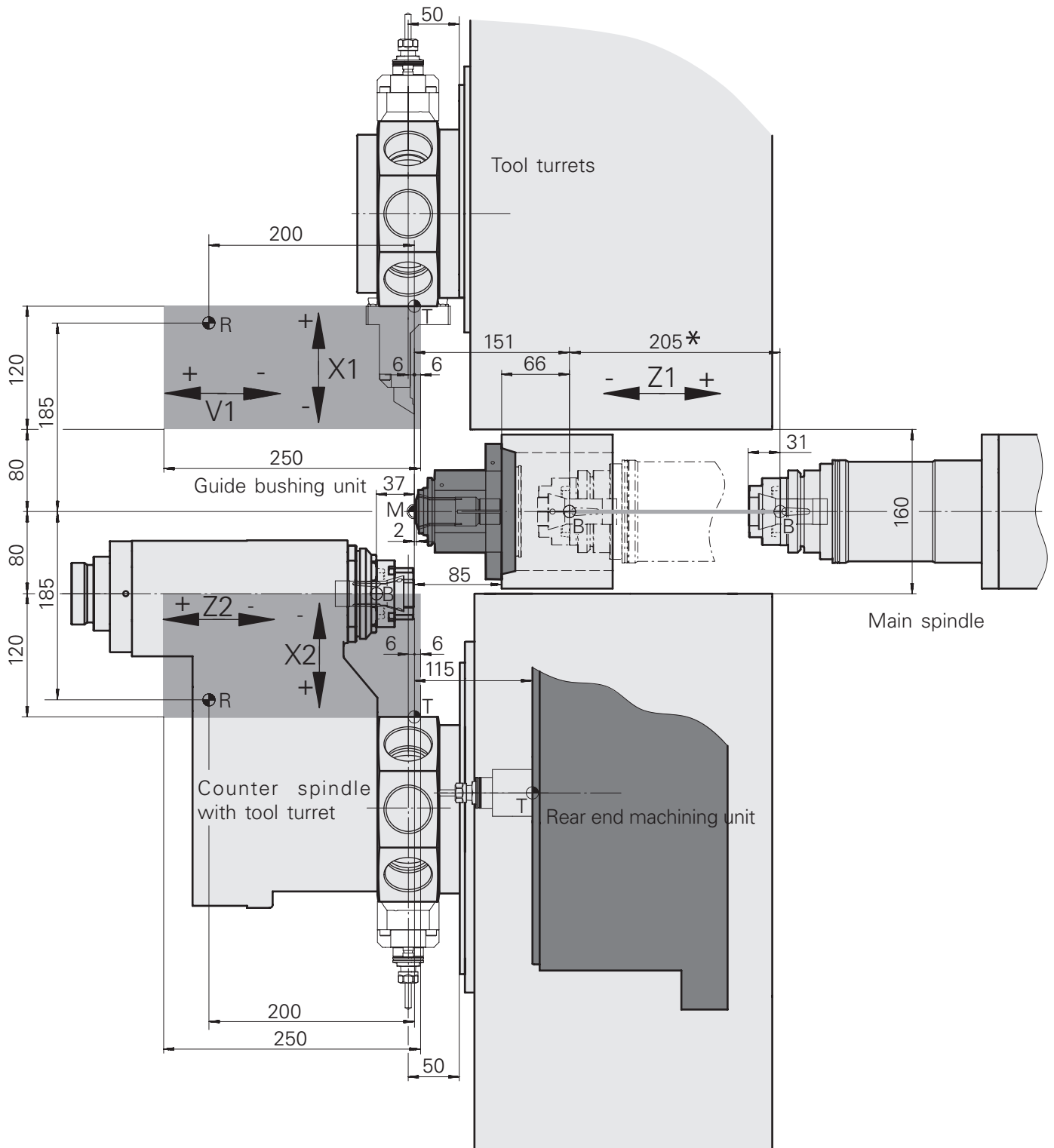

\*The stroke depends on the clamping device (Z1)

Work area TRAUB TNL 18-7

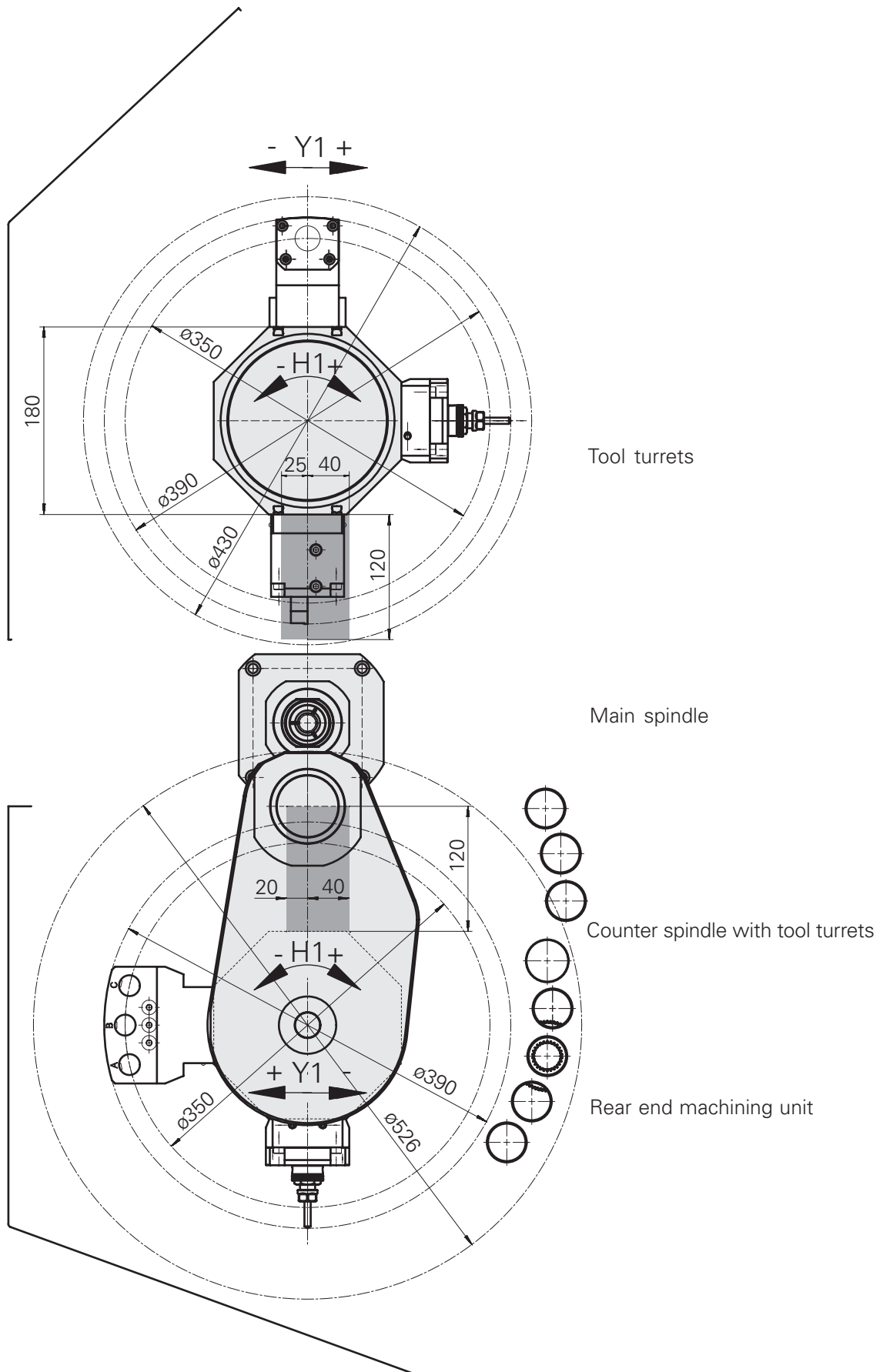

**Work area TRAUB TNL 18-7B**

B-axis 90°

Fixed headstock turning

- ⊕ T = tool holder zero
- ⊕ B = reference point
- R = reference point
- ⊕ M = machine zero

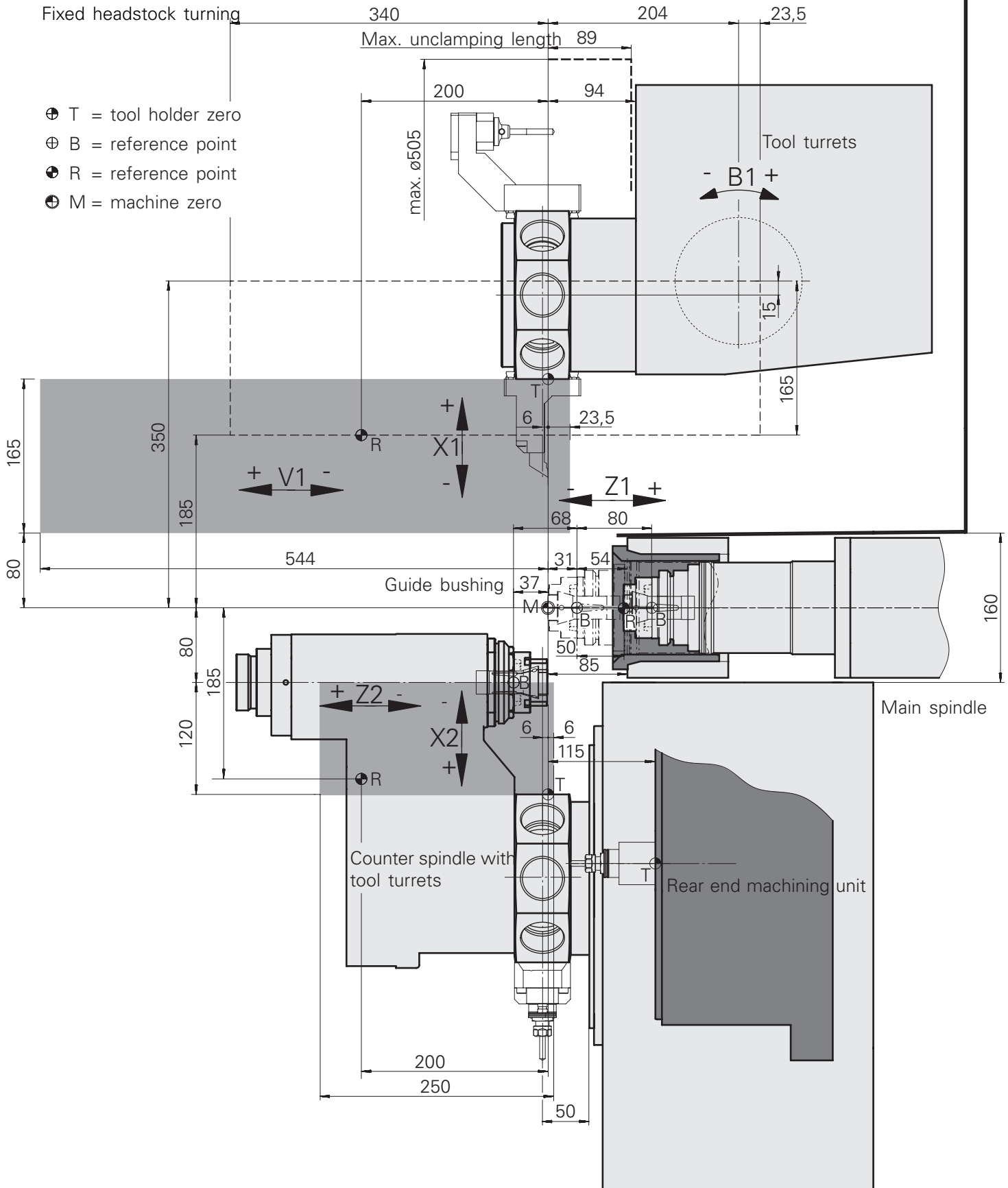

### Work area TRAUB TNL 18-7B

B-axis 90°

Sliding headstock turning

- ⊕ T = tool holder zero
- ⊕ B = reference point
- ⊕ M = machine zero

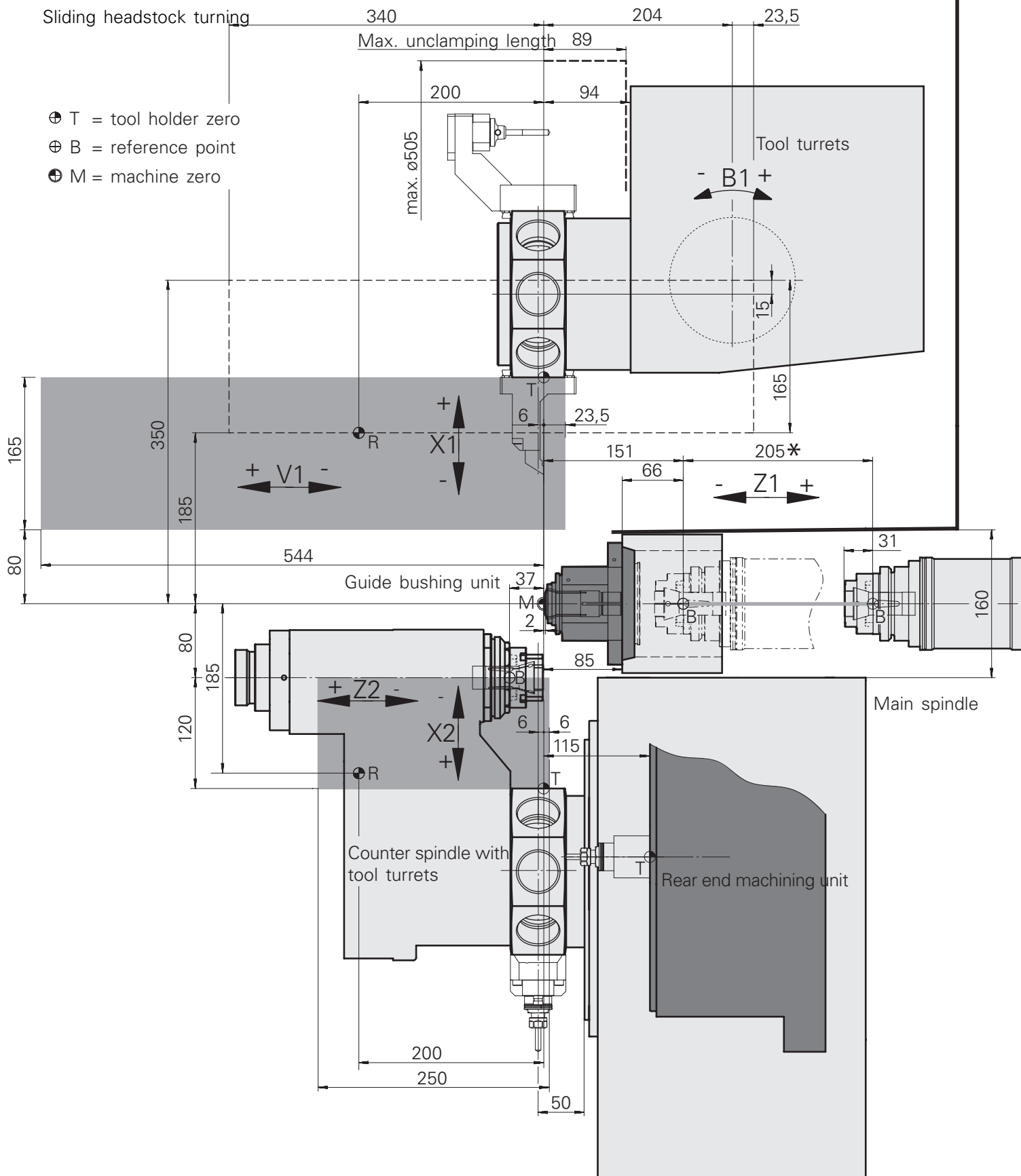

\*The stroke depends on the clamping device (Z1)

### Work area TRAUB TNL 18-7B

B-axis -45°, machining to main spindle  
Sliding headstock turning

- ⊕ T = tool holder zero
- ⊕ B = reference point
- ⊕ M = machine zero

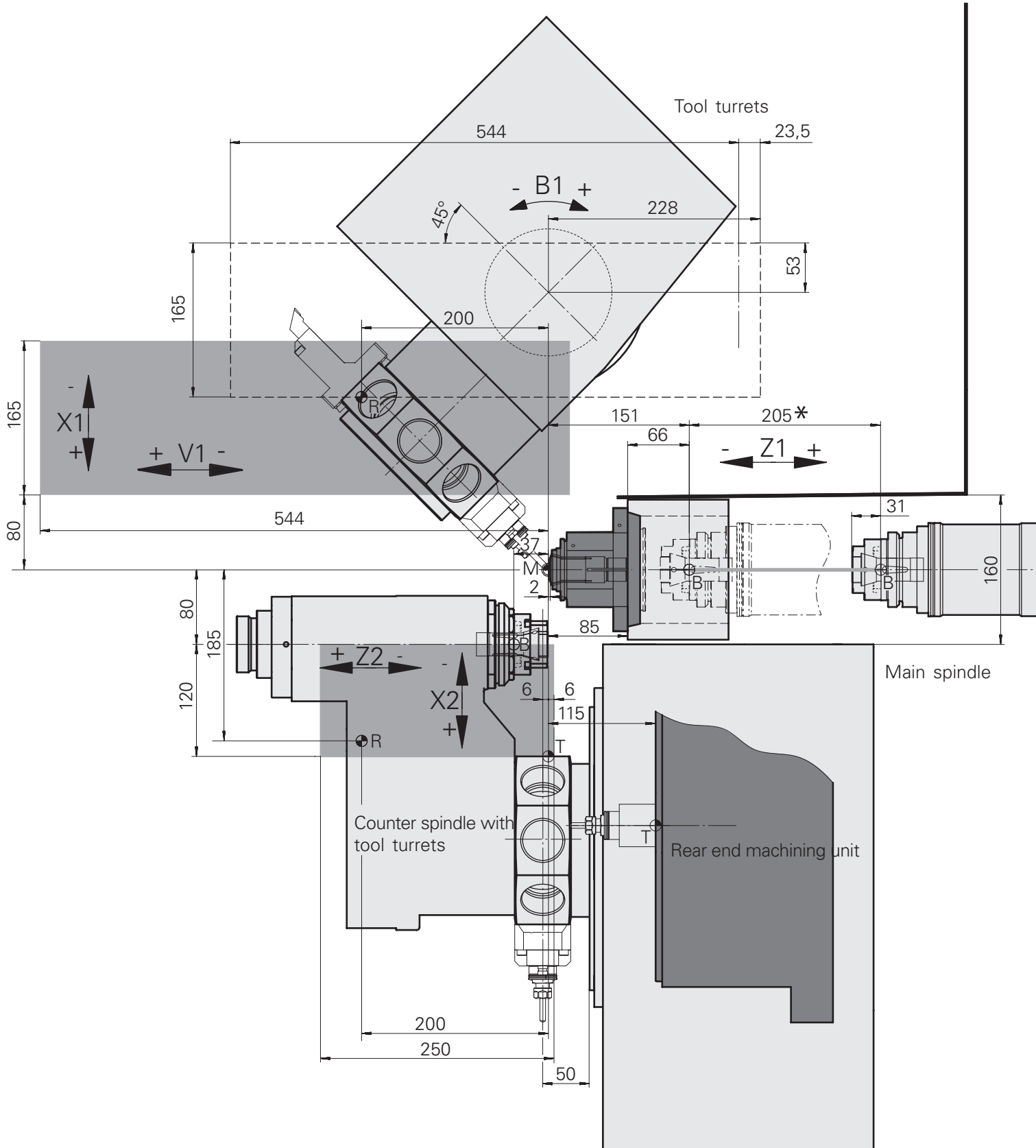

\*The stroke depends on the clamping device (Z1)

### Work area TRAUB TNL 18-7B

B-axis -90°, machining to main spindle  
Sliding headstock turning

- ⊕ T = tool holder zero
- ⊕ B = reference point
- ⊕ M = machine zero

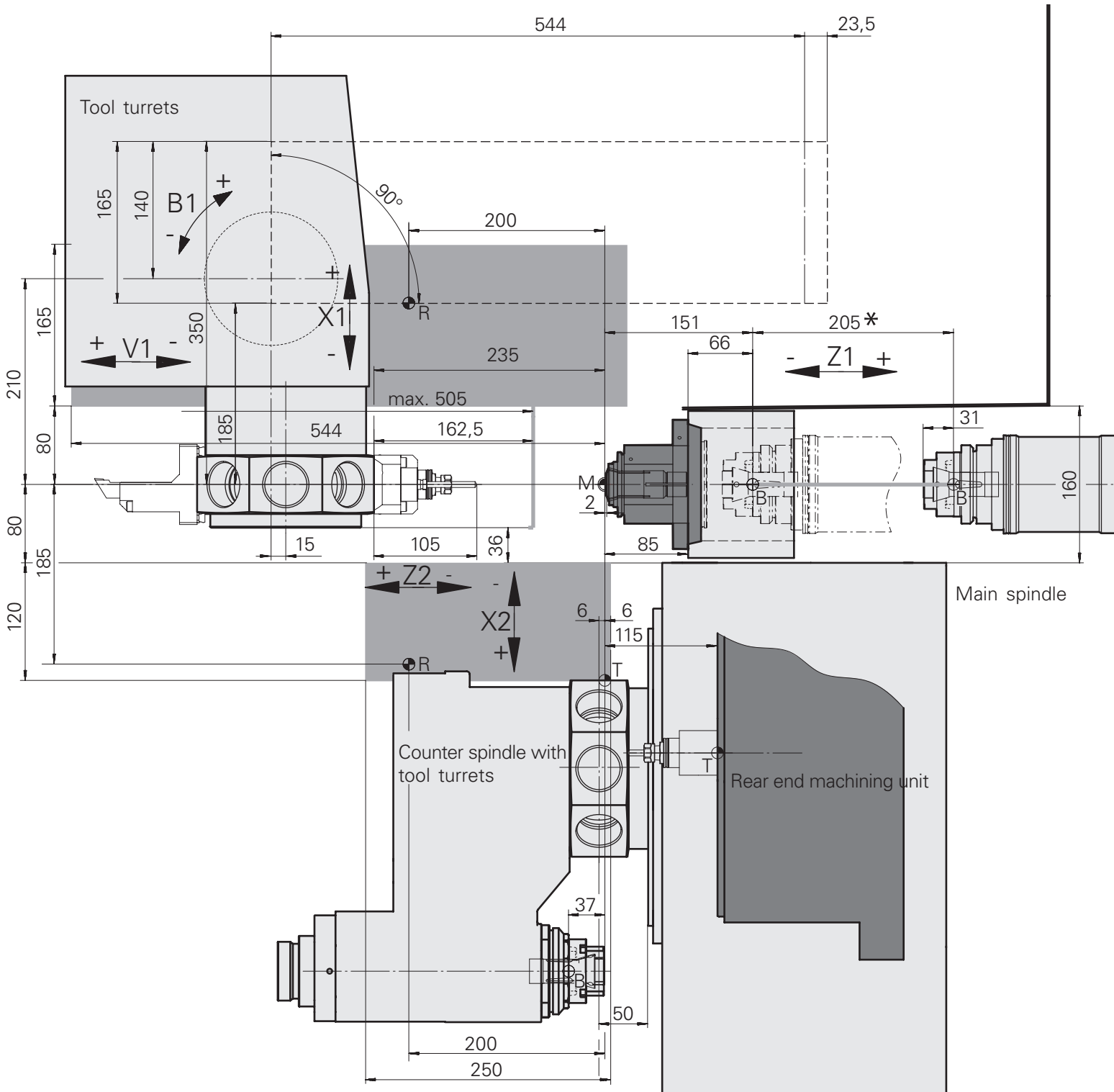

\*The stroke depends on the clamping device (Z1)

### Work area TRAUB TNL 18-7B

B-axis 5° / -95°, machining to main spindle  
 Sliding headstock turning

- ⊕ T = tool holder zero
- ⊕ B = reference point
- ⊕ M = machine zero

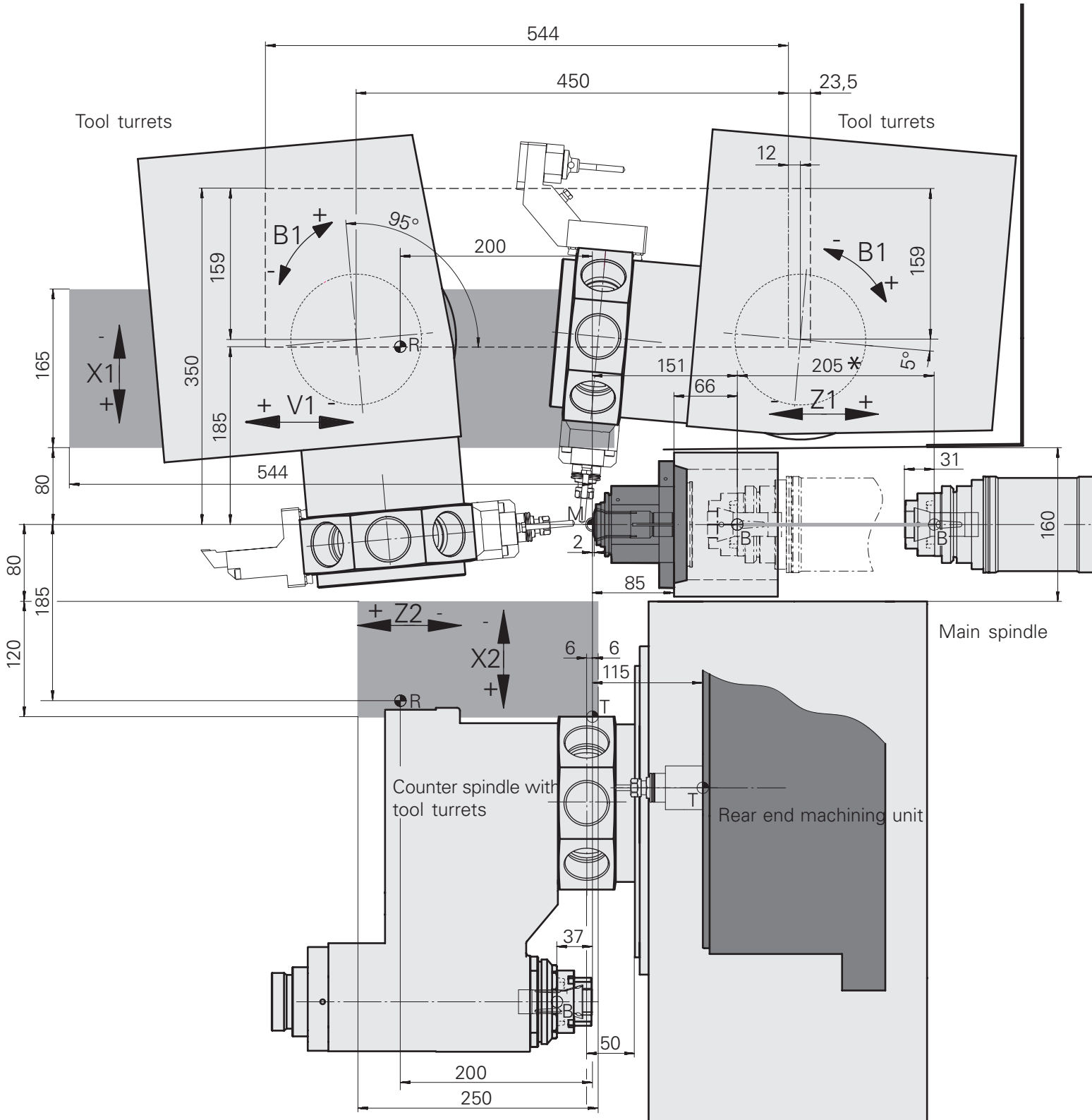

\*The stroke depends on the clamping device (Z1)

### Work area TRAUB TNL 18-7B

B-axis -45°, machining to counter spindle  
Sliding headstock turning

- ⊕ T = tool holder zero
- ⊕ B = reference point
- ⊕ M = machine zero

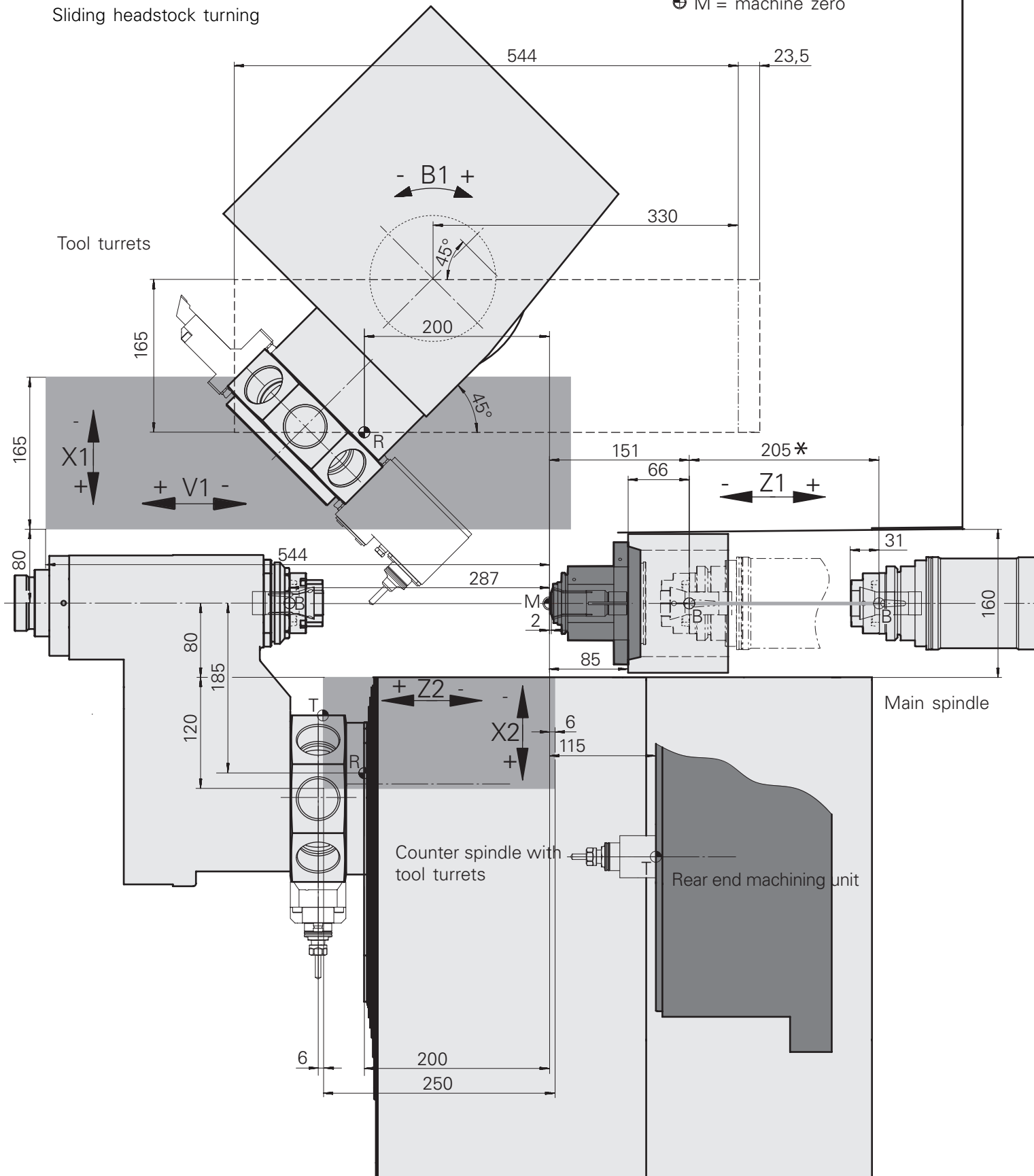

\*The stroke depends on the clamping device (Z1)



Work area TRAUB TNL 18-7B

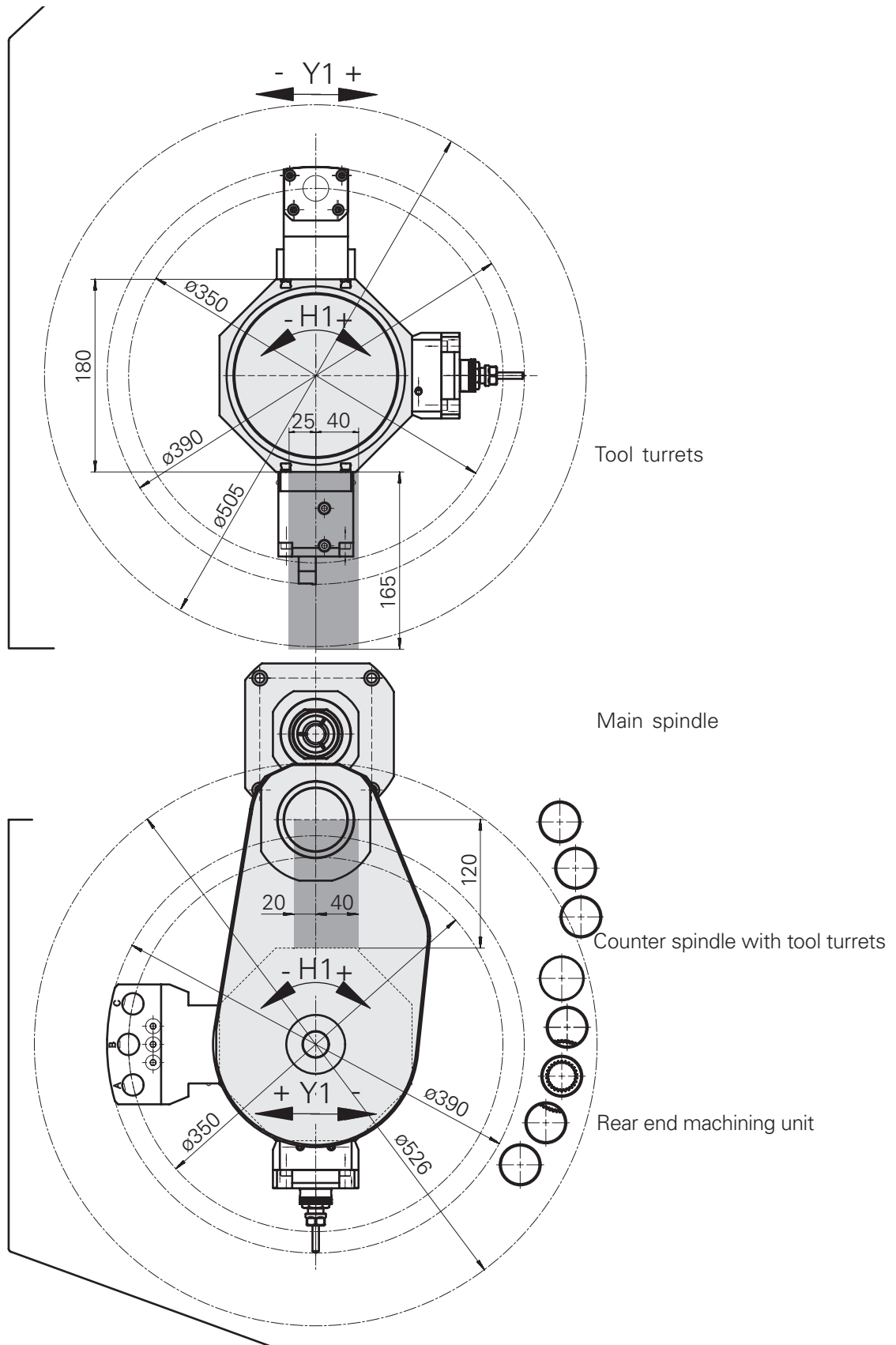

## Rear end machining unit

3 stationary stations T16, T17, T18 for simultaneous machining

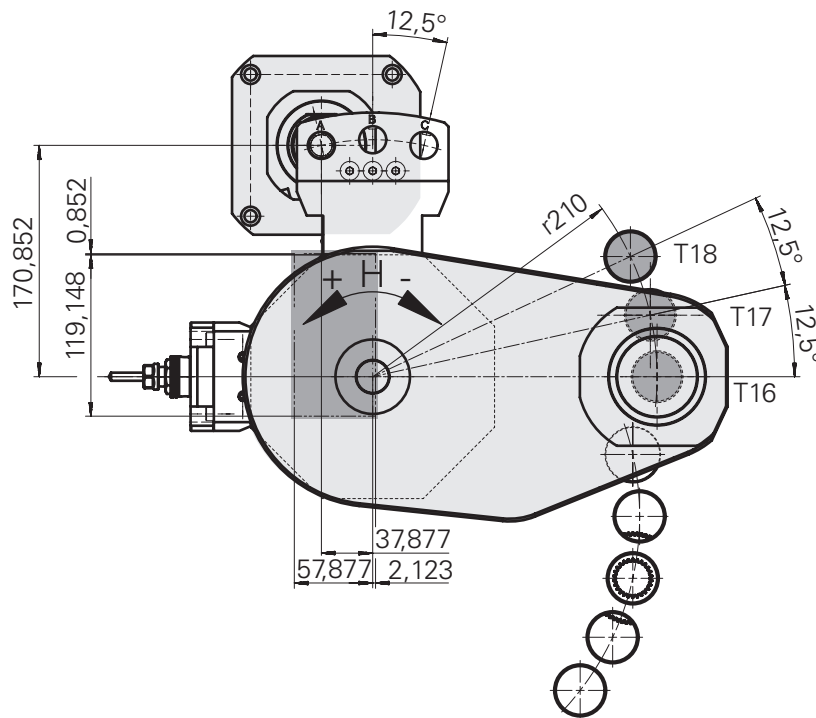
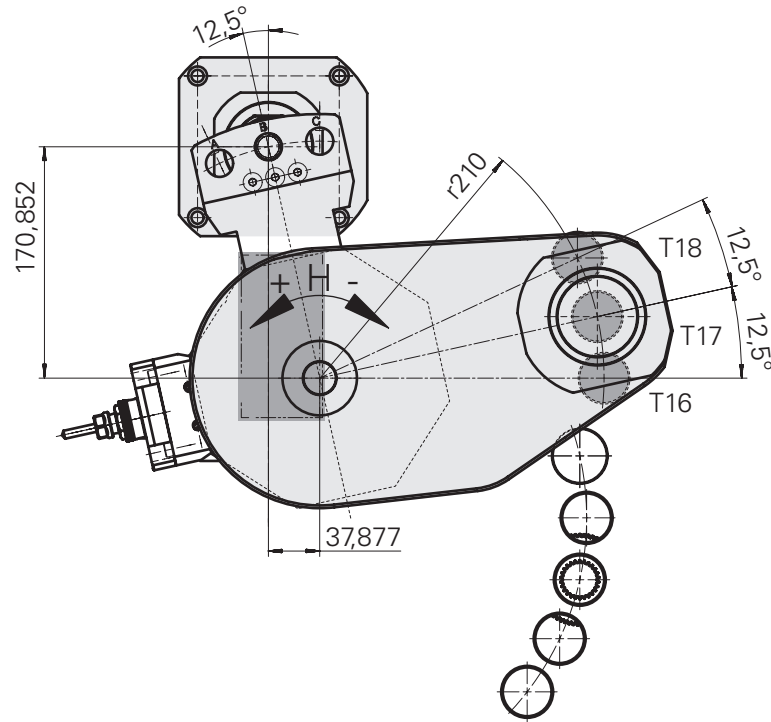

## Rear end machining unit

Station T15 for flushing

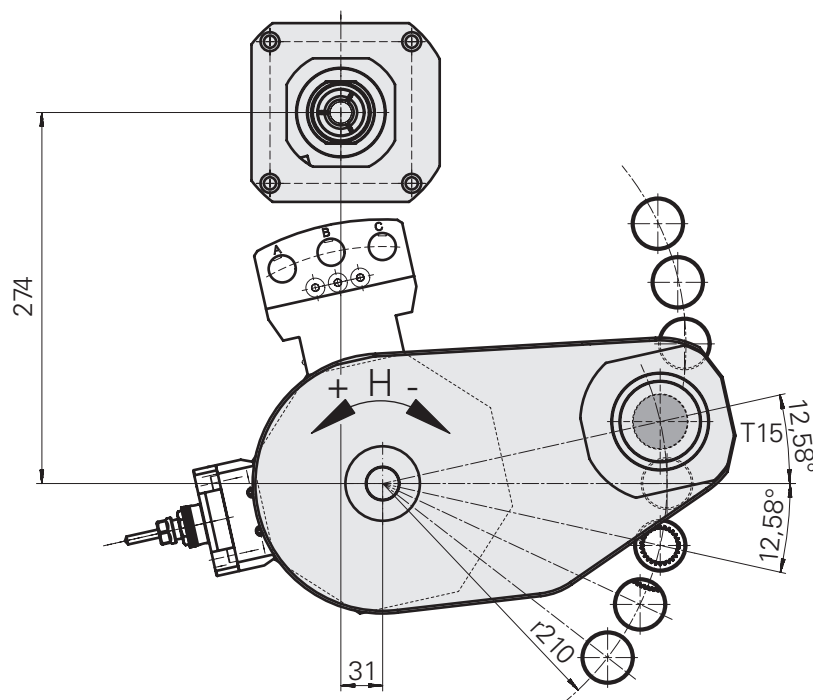

## Rear end machining unit

4 stations T11, T12, T13, T14 for non-simultaneous machining

Stations T12, T13, T14 can be equipped with live tool holders

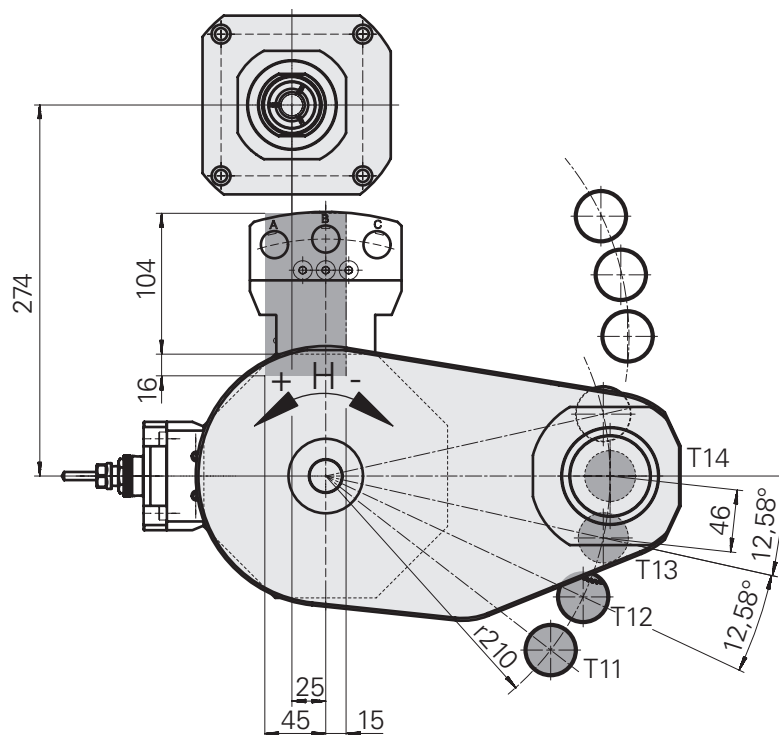

## Back Machining Device with Milling Unit, Single

$n_{max}$  10000 rpm

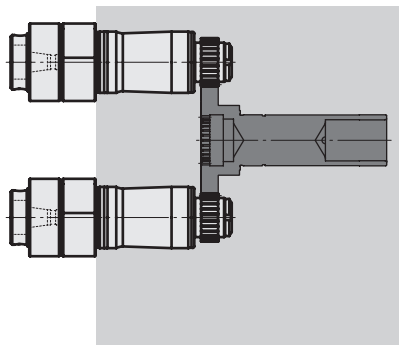

$n_{max}$  10000 rpm

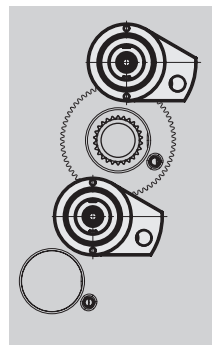

T14 Drive with external serration  
 $n_{max}$  10000 rpm

T13

T12 drive with external serration  
 $n_{max}$  10000 rpm

T11 Without drive unit

$n_{max}$  4000 rpm

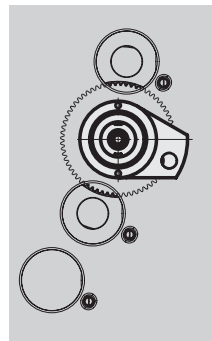
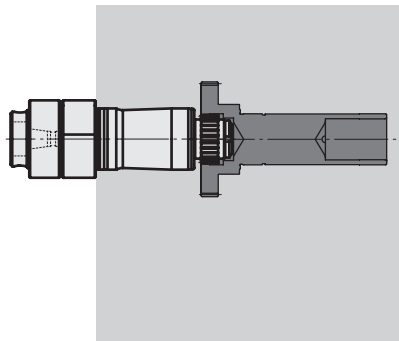

T14

T13 Drive with internal serration  
 $n_{max}$  4000 rpm

T12

T11

## Back Machining Device with Milling Unit, dual

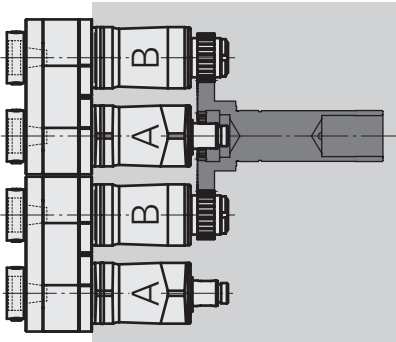
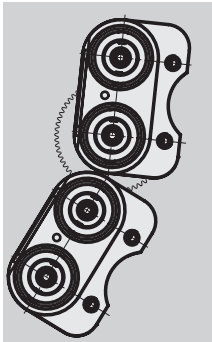
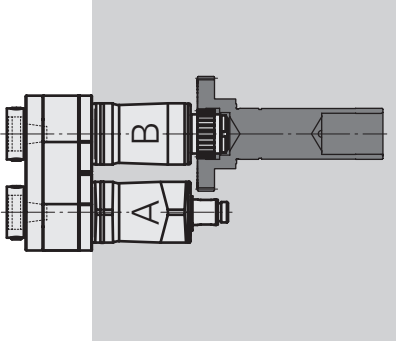
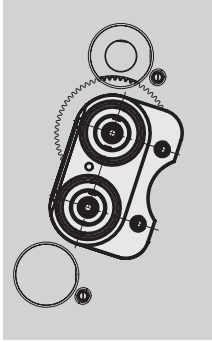
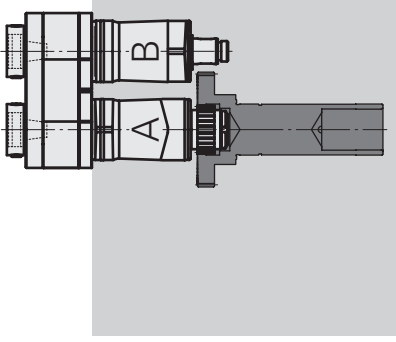
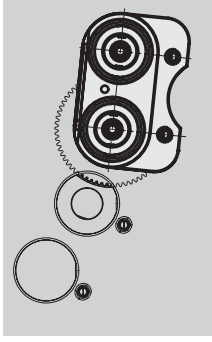
	Tool holder gear to spindle B		
$n_{max}$ 10000 rpm			T14 Drive with external serration $n_{max}$ 10000 rpm
$n_{max}$ 10000 rpm			T13
$n_{max}$ 10000 rpm			T12 drive with external serration $n_{max}$ 10000 rpm
$n_{max}$ 10000 rpm			T11 Without drive unit
	Tool holder gear to spindle B		
$n_{max}$ 4000 rpm			T14
$n_{max}$ 4000 rpm			T13 Drive with internal serration $n_{max}$ 4000 rpm
			T12
			T11
	Mount tool holder gear to spindle A		
$n_{max}$ 4000 rpm			T14
$n_{max}$ 4000 rpm			T13 Drive with internal serration $n_{max}$ 4000 rpm
			T12
			T11

## Performance diagram

Live tools  
Counter spindle, lower tool turret

Speed range 0-12000 rpm

 For information on how to use the chart, see Chapter "Technical Information."

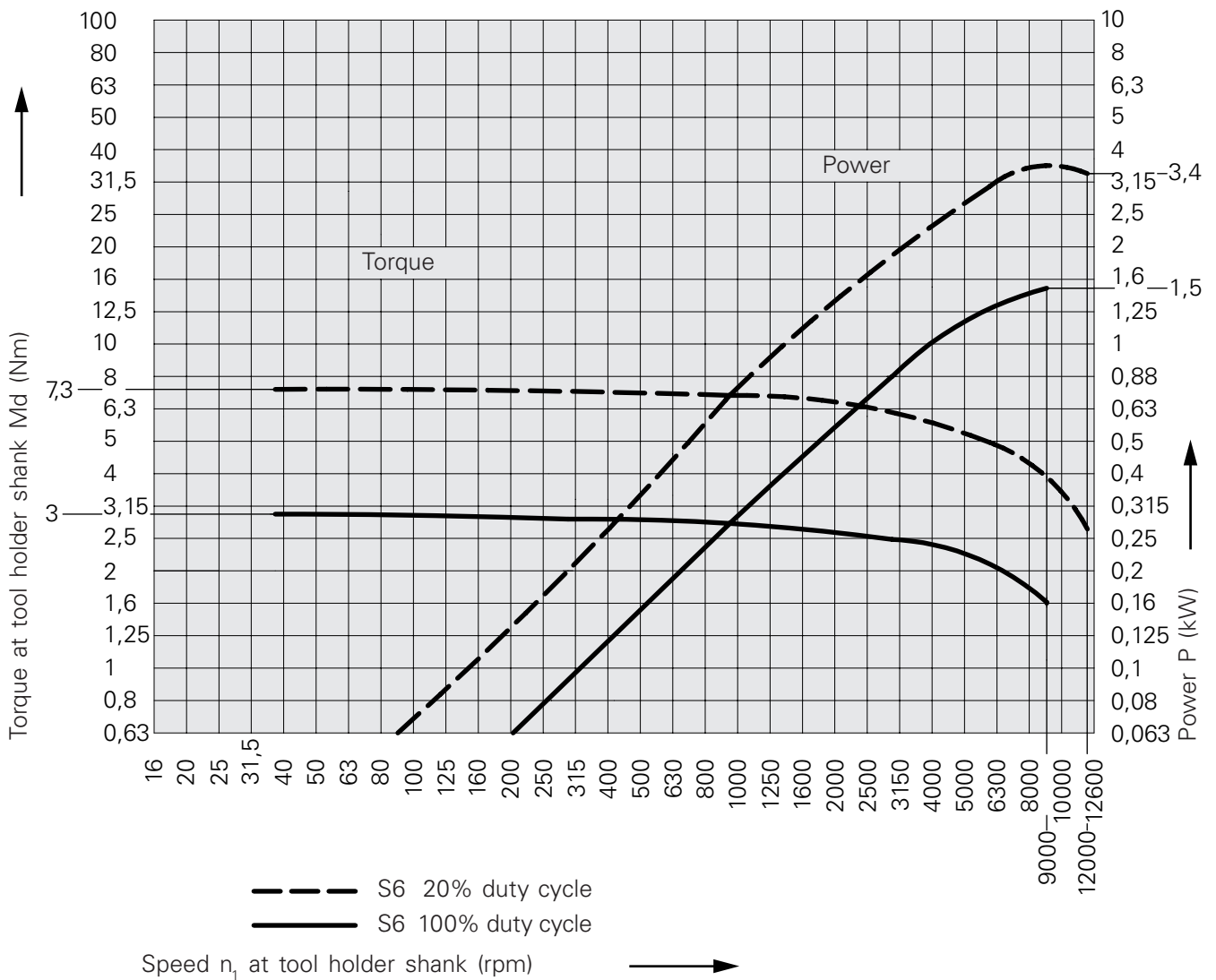

## Performance diagram

Live tools  
Top tool turret

 For information on how to use the chart, see Chapter "Technical Information."

Speed range 0-12000 rpm

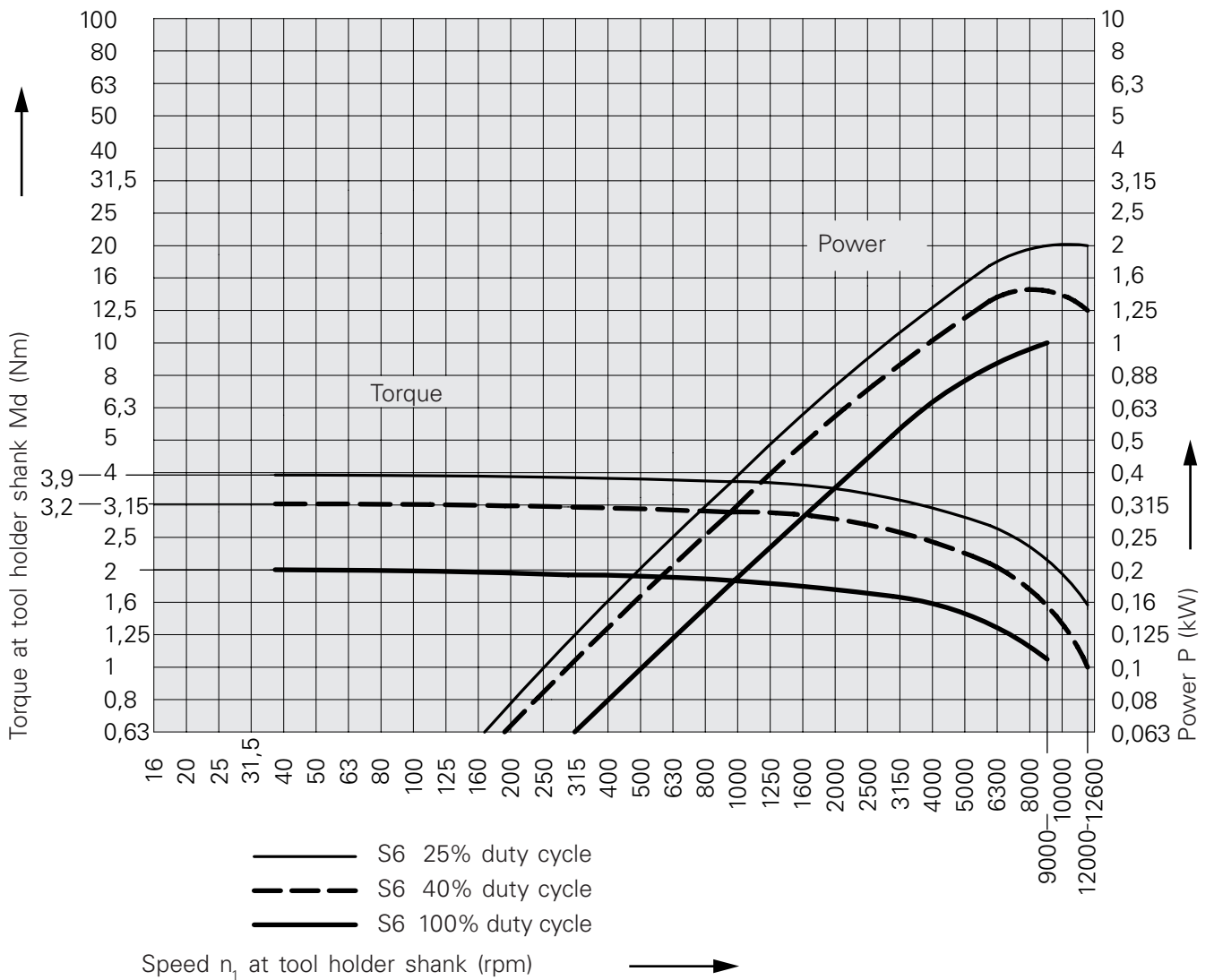



## Performance diagram

Live tools  
Rear end machining unit, station T13

Speed range 0-4000 rpm

 For information on how to use the chart, see Chapter "Technical Information."

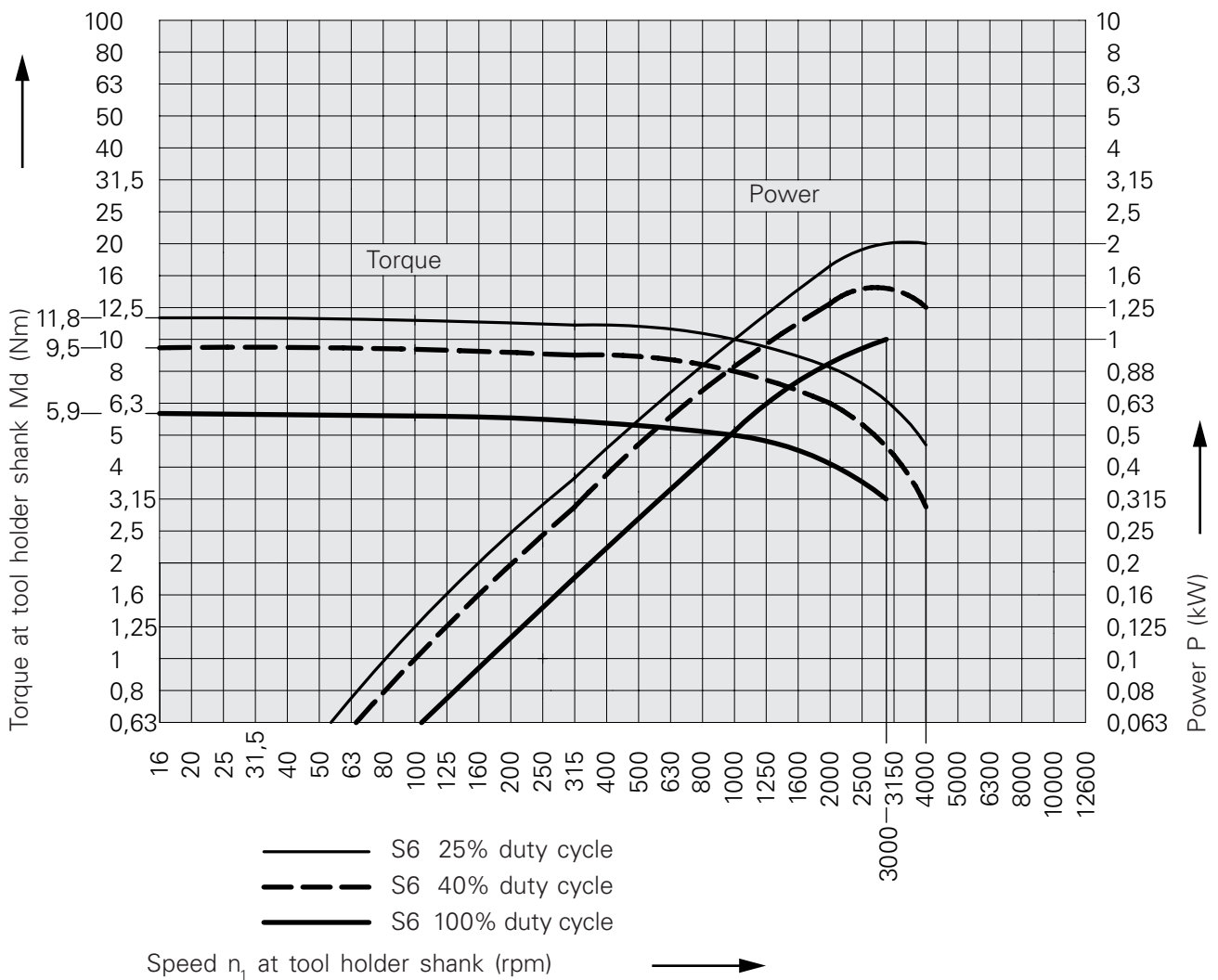

## Performance diagram

Live tools  
rear end machining unit, stations T12, T14

Speed range 0-10000 rpm

 For information on how to use the chart, see Chapter "Technical Information."

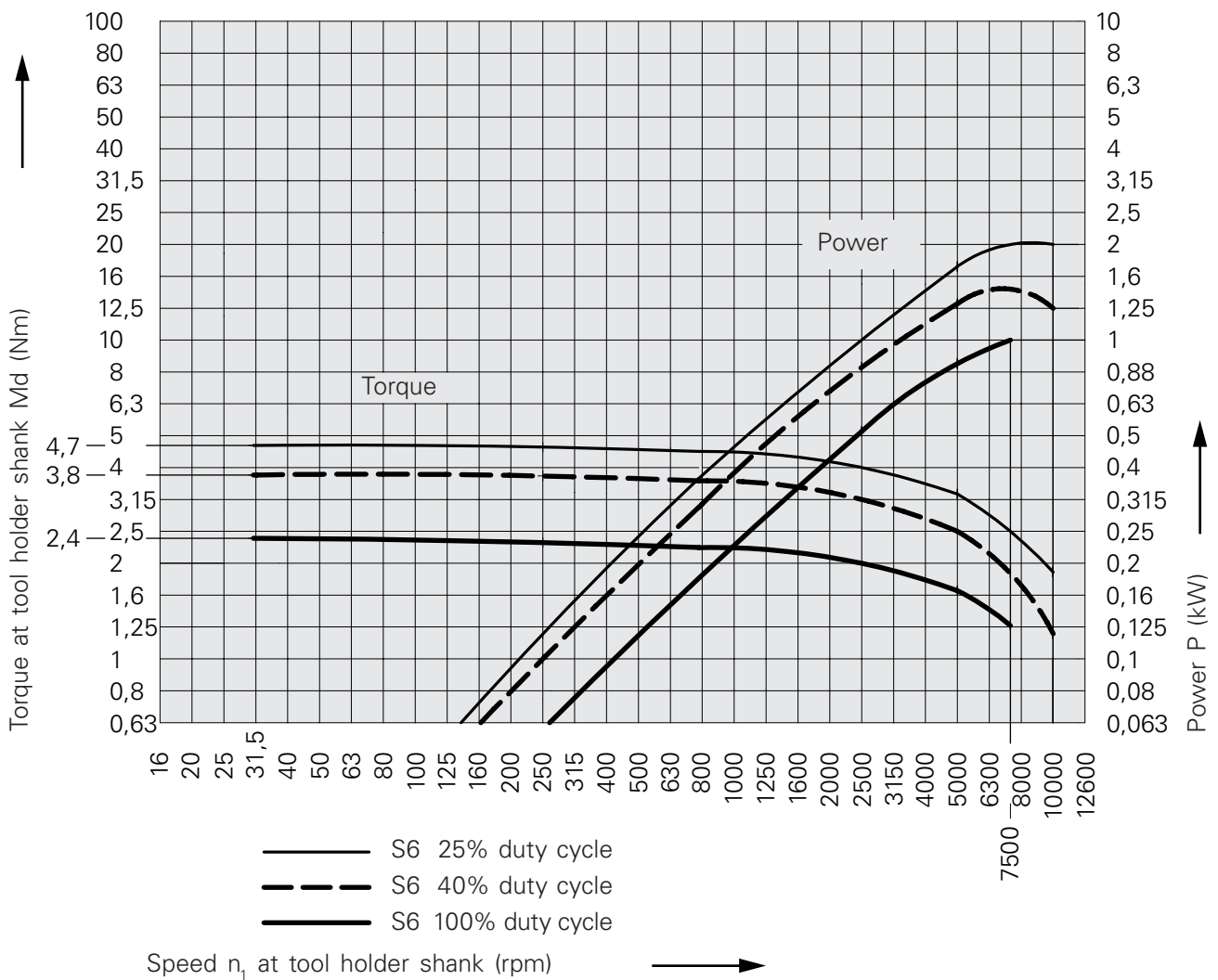

## Quick-Change Insert WFB

Operating Instructions  
2-piece shrink fit chuck

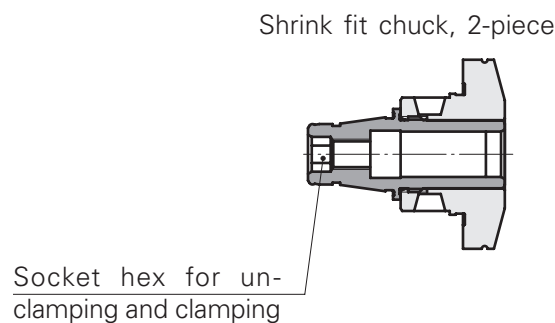
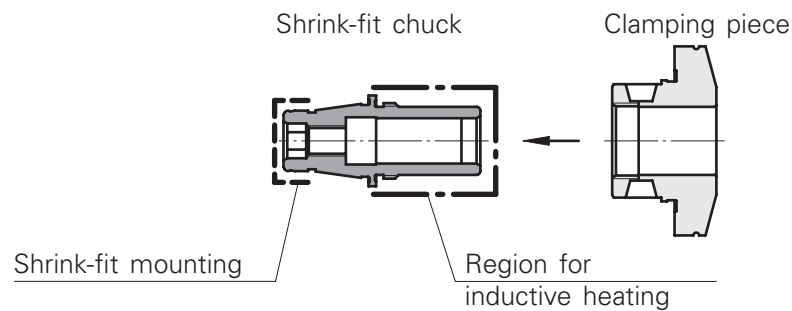

### Working Principle

- 1) Remove two-piece shrink fit chuck.  
Only the socket hex inside the shrink-fit chuck may be used for unclamping and clamping.
- 2) Accept the shrink-fit chuck into the basic mounting (collet chuck) on the clamping collar.
- 3) Use induction heating and shrink-fit cutting tool.
- 4) Let the shrink-fit chuck cool down.
- 5) Mount the clamping piece and shrink-fit chuck as a unit.

### Cleaning

After several shrink-fit cycles, the cylindrical section of the shrink-fit chuck should be cleaned with steel wool or the like.



Short type WFB shrink-fit chucks consist of the actual shrink-fit chuck and the clamping piece. The two parts are supplied assembled and bear the same label.

Only parts with identical labels may be assembled as a 2-piece shrink-fit chuck.





# INDEX



**INDEX-Werke GmbH & Co. KG  
Hahn & Tessky**  
Plochinger Straße 92  
D-73730 Esslingen, Germany  
[www.index-werke.de](http://www.index-werke.de)

**TRAUB-Drehmaschinen  
GmbH & Co. KG**  
Hauffstraße 4  
D-73262 Reichenbach, Germany  
[www.traub.de](http://www.traub.de)

**TECHNICAL ADVICE**  
Phone +49 (0) 711 3191-9854  
Fax +49 (0) 711 90129-343  
[werkzeughalter@traub.de](mailto:werkzeughalter@traub.de)

**TECHNICAL ADVICE**  
Phone +49 (0) 7153 502-9854  
Fax +49 (0) 711 90129-343  
[werkzeughalter@traub.de](mailto:werkzeughalter@traub.de)

**SPARE PARTS SALE**  
Phone +49 (0) 711 3191-600  
Fax +49 (0) 711 3191-790  
[ersatzteile@index-werke.de](mailto:ersatzteile@index-werke.de)

**SPARE PARTS SALE**  
Phone +49 (0) 7153 502-600  
Fax +49 (0) 7153 502-685  
[ersatzteile@traub.de](mailto:ersatzteile@traub.de)

# Tool Holder Catalog

**TRAUB TNL 18-9**

Technical information

Usage information

## **Disclaimer**

The illustrations in this documents may deviate from the delivered product. We reserve the right to make changes due to errors or based on technical advances.

## **Abbreviations used in the catalog:**

EC = external cooling lubricant supply

approx.= approximately

D = diameter

max = maximum

min = minimum

IC = internal cooling lubricant supply

MT = Morse taper

R = radius

s = wrench size

ST = steep taper

SQ = square

## **A word on copyright**

This document is proprietary and was originally written in German. Its reproduction and distribution in whole or in individual parts without permission of the copyright owner is prohibited and will be prosecuted under criminal or civil law. All rights reserved, including for translation.

© Copyright by INDEX-Werke GmbH & Co. KG Esslingen 2014

© Copyright by TRAUB Drehmaschinen GmbH & Co. KG Reichenbach 2014



---

Table of contents .....	0
Technical Information TRAUB TNL 18 .....	1
Usage information TRAUB TNL 18.....	2
Stationary tool holder, turret head.....	3
Live tool holder, turret head.....	4
Stationary tool holder, rear end machining unit .....	5
Live tool holder, rear end machining unit.....	6
Accessories – Quick-change inserts.....	7
Accessories – TRAUB TNL 18 .....	8
Product information.....	9

For accessories for tool holders visit <http://infoshop.index-werke.de/>



## **Table of Contents**



---

	<b>Catalog page</b>
<b>Warranty</b>	<b>1-2</b>
<b>Information on wear parts</b>	
<b>Inspection of live tool holders and guide bushings</b>	

---

<b>Coolant supply</b>	<b>1-3</b>
<b>Cooling lubricant filtering</b>	
<b>Cleaning</b>	

---

<b>Speed ratio specifications for tool holders</b>	<b>1-4</b>
--	------------

---

<b>Direction-of-rotation information of tool holders</b>	<b>1-5</b>
--	------------

---

<b>Notes on how to use the chart when using tool holders</b>	<b>1-6</b>
--	------------

---

<b>Tool turrets</b>	<b>1-7</b>
<b>Swivel drive as rotary axis</b>	
<b>Turret head</b>	
<b>Live tool holder, turret head</b>	

---

<b>Tool holder system on tool turret</b>	<b>1-8</b>
--	------------

---

**Catalog page**

---

**Attaching/detaching the tool holders  
to/from the tool turret** **1-9**

---

**Tool drive on the tool turret** **1-10**  
**Dry run for live tool holders**

---

**Cleaning the tool drive** **1-11**

---

**Blanking plug** **1-12**

---

**WFB interface,** **1-13**  
**Mounting**  
**Cleaning and care**  
**Tightening torques**

---

---

		Catalog page
	<b>Modular system of the TRAUB TNL 18-9</b>	<b>2-2</b>
<b>904060</b>	<b>Work area TRAUB TNL 18-9</b> Fixed headstock turning	<b>2-3</b>
<b>904060</b>	<b>Work area TRAUB TNL 18-9</b> Sliding headstock turning	<b>2-4</b>
<b>904060</b>	<b>Work area TRAUB TNL 18-9</b>	<b>2-5</b>
	<b>Performance chart</b> Driven tools Bottom tool turret Speed range 0-12000 rpm	<b>2-6</b>
	<b>Performance chart</b> Driven tools Top tool turret Speed range 0-12000 rpm	<b>2-7</b>
	<b>Quick-Change Insert WFB</b> Operating Instructions 2-piece shrink fit chuck	<b>2-8</b>

---





## **Technical Information**

### **TRAUB TNL 18-9**

## Warranty



When using tool holders that have not been set, checked and labeled accordingly by INDEX TRAUB, warranty is not applicable to the tool drive.

## Information on wear parts

Tool holders and guide bushings are wear parts that require correct handling.

In order to ensure a long service life, compressed air or cooling lubricant must not enter the gap seals of the holders or of the guide bushings.

## Inspection of live tool holders and guide bushings



Tool holders and guide bushings must be inspected at regular intervals (at least twice a year) for smooth running and play.



The drive pinion and drive clutch of the live tool holders must be subjected to a visual inspection for damage or wear.

If one of the above-mentioned defects is detected during the inspection of the tool holders or guide bushings, they must be returned immediately for preventive maintenance or repair to the following address:

TRAUB Drehmaschinen GmbH & Co. KG  
Hauffstrasse 4  
D-73262 Reichenbach, Germany  
Phone +49 (0) 7153 502-554  
werkzeughalter@traub.de

### Tool holders with cooling lubricant supply



Tool holders marked with this symbol must be operated with cooling lubricant (no dry run permitted).



Tool holders marked with this symbol must be operated with cooling lubricant when converting from external cooling lubricant supply to internal cooling lubricant supply. Observe dry run capability of IC attachment!

### Cooling lubricant filtering

When using live tool holders with internal cooling lubricant supply, it is necessary to use a cooling lubricant filter system with a retained particle size  $\leq 50 \mu$ .

### Cleaning live tool holders

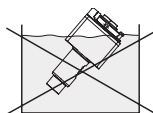

Live tool holders must never be immersed in cleaning fluid since mixing the cleaning fluid with the bearing grease will reduce the service life of the tool holders.

### Speed ratio specifications on tool holders

The value to be programmed is specified in the documentation and on the live tool holders  
( = the input in the NC program).

$$n_{\text{prog}} = n_{\text{TOOL}} \times i$$

$n_{\text{TOOL}}$  = speed at cutting tool edge

$n_{\text{PROG}}$  = speed to be programmed

$i$  = speed ratio in the tool holder

This means: the speed increase or speed reduction is not specified as a fraction but as **a number**.

This gives speed **increase** ratios as numbers **smaller than 1**.

Example:  $i = 0.333$  (corresponds to  $i = 1:3$ )  
 $i = 0.676$  (corresponds to  $i = 1:1.48$ )

Speed **reduction** ratios as numbers **greater than 1**

Example:  $i = 2$  (corresponds to  $i = 2:1$ )  
 $i = 1.333$  (corresponds to  $i = 4:3$ )



The tool holder speed ratio is engraved in TRAUB TNL tool holders.

### Direction of rotation specification

Definition of the viewing direction

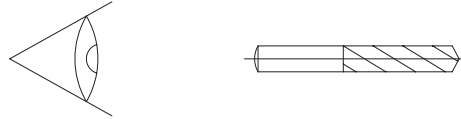

The viewing direction for determining the direction of rotation is always from the rear (i.e., from the drive direction) towards the shaft.



On the machine side, the direction of rotation has been set by parameters such that M03 always denotes clockwise rotation and M04 counter-clockwise run at the interface of the drive pinion of the tool holder.

The direction of rotation given on the holder therefore refers to a "change in direction within the holder"

M03 and M04 are machine functions to be programmed.

The  and  arrows indicate the direction of rotation of the cutting edges.

This means:

#### No reversal of direction of rotation



- When the holder drive shaft has the **same** direction of rotation as the tool cutting edge, the clockwise direction of run must be specified by M03 (clockwise rotation). Accordingly, counter-clockwise run must be specified by M04.

#### Reversal of direction of rotation



- When the holder drive shaft has the **opposite** direction of rotation as the tool cutting edge, the clockwise direction of rotation must be specified by M04. Accordingly, counter-clockwise run must be specified by M03.

Example

#### No reversal of direction of rotation

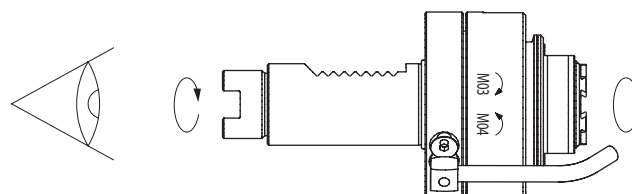

**Notes on how to use the chart  
when using tool holders**

The chart relates to the output speed **n** of the tool unit. The tool speed can be read directly from the chart only if the internal speed ratio **i** in the tool holder is 1:1.

For tool holders (e.g., VDI holders) with an internal speed ratio  $i \neq 1$ , the output speed **n** of the tool unit to be programmed must be calculated from the required tool speed and the speed ratio **i**. Afterwards, the actual powers or torques can be read off or determined.

Example (at 100% duty cycle):

<b>live tool unit, tool speed <math>n_{\text{Tool}} = 1000 \text{ rpm}</math></b>	
Internal speed ratio $i$ of the tool holder	$i = 4$
Programmed speed $n_{\text{prog}}$ for the drive of the unit	$n_{\text{prog}} = n_{\text{Tool}} \times i =$ $1000 \text{ rpm} \times 4 = 4000 \text{ rpm}$
Torque $M_{\text{Tool}}$ at the output of the tool holder	Read-out $M_d$ at speed $n_{\text{prog}} = 4000 \text{ rpm} = 1.6 \text{ Nm}$ $M_d = M_{\text{Tool}} : i$ Formula changed: $M_{\text{Tool}} = M_d \times i = 1.6 \text{ Nm} \times 4 = 6.4 \text{ Nm}$
Power $P$ at the output of the tool holder $\approx$ Power $P$ at the output of the setup	Read-out at 4000 rpm $\rightarrow P = 0.67 \text{ kW}$ calculated: $P = 2 \times \pi \times n_{\text{prog}} \times M_d$ $P = \frac{2 \times \pi \times 4000 \times 1.6 \text{ Nm}}{60 \times 1000} = 0.67 \text{ kW}$

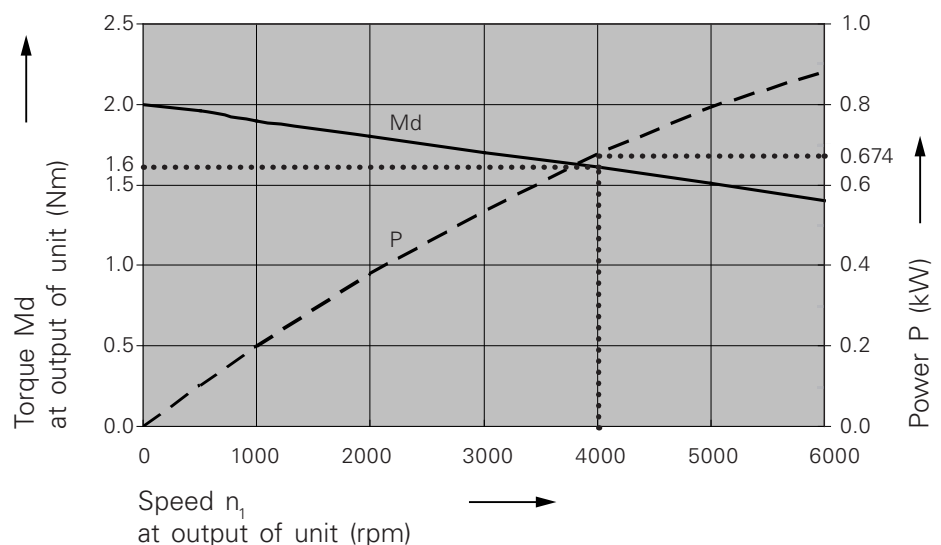

The speed ratio and the technical data of each tool holder are indicated on the next pages.

## Tool turrets

The TNL 18-9 is equipped with 2 tool turrets: The tool turrets consist of the swivel drive, turret head, tool drive, and axis drives.

## Swivel drive as rotary axis

The tool turrets are equipped with a rotary axis. It consists of a cycloidal gearbox (eccentric gearbox) in which the torque is transmitted via curved disks.

This allows high impact loads on the drive (up to 500%), low-wear operation, and low friction losses.

The gearbox is not self-locking. Therefore, the turret head is connected directly with a measuring system that reports the exact position and compensates the cutting forces. This allows top precision turning and milling operations.

## Turret head

Each turret head has 8 tool stations for stationary and live tool holders. All stations are equipped with a cooling lubricant transfer unit. The tool stations 1 and 7 on the upper turret are equipped with an additional fluid transfer station. It can be used either as a sealing air port or as a high-pressure port for cooling lubricant. In this case, the appropriate tool holder and the valves must be available.

The turret heads have fixing inclines for the fixing pins of the tool holders on both sides along their circumference.

## Live tool holder, turret head



When using live tool holders in the turret head, only tool holders with a spur gear with 18 teeth may be used.

When using live tool holders with a different number of teeth, such as TRAUB TNL 32 with 23 teeth, the tool drive will be destroyed.

### Tool holder system on tool turret

The tool holder system is a TRAUB compact shank.

The turret head has a locally hardened fixing incline on both sides along its circumference.

When the tool holder is inserted into the turret head, the tool holder aligns itself automatically with the fixing inclines by means of the fixing pins. The tool holders are fastened to the face of the stations using cylinder head screws.

Most of the tool holders have elastic fixing pins. The elasticity of the fixing pins compensates the width tolerance of the turret head, and the turret head is not damaged in case of a collision.

The fixing pins are arranged eccentrically and are adjusted to their exact positions and sealed by TRAUB.



The customer may not manipulate the adjusted and sealed fixing pins of the tool holders.

The fixing pins can be replaced and readjusted by the manufacturer, e.g., after a collision.

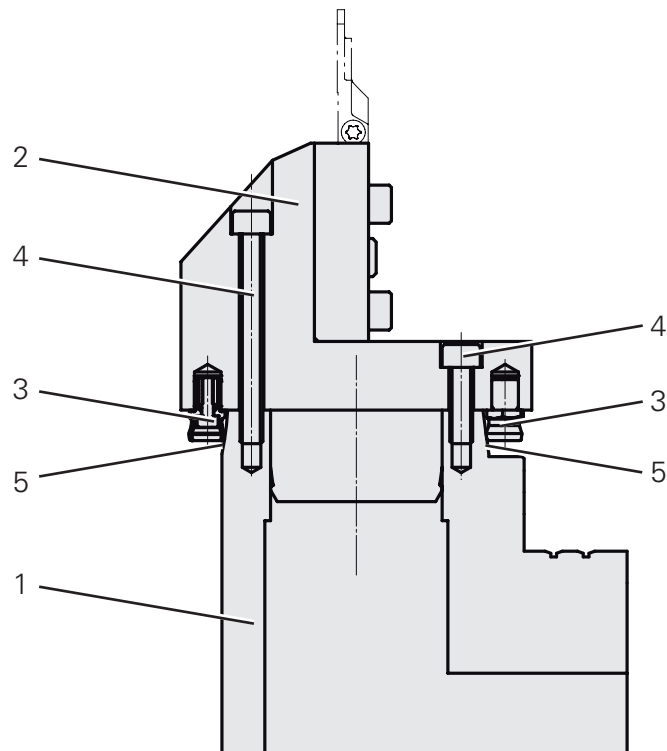

- 1 Turret head
- 2 Tool holder
- 3 Fixing pin
- 4 Cylinder head screws
- 5 Fixing incline



### Attaching/Detaching the Tool Holders to/from the Tool Turret

Swivel the turret head into the required position.  
Carefully remove chips and dirt from the tool holder (or the blanking plug) to be replaced and its surrounding area using a cleaning gun.



Chips and dirt must not enter into the inside of the turret head when tool holders are being replaced.

Clean the removed tool holder and tool receptacle.

Check that the proper mounting screws have been installed on the replacement tool holder. The mounting screws should not protrude more than 12 mm from the tool holder.

Clean and install the tool holder.

For live tool holders, the spindle must be slightly moved so that the drive gear can be pushed into crown wheel.

Tighten mounting screws. Tightening torque  $M_a=14$  Nm.

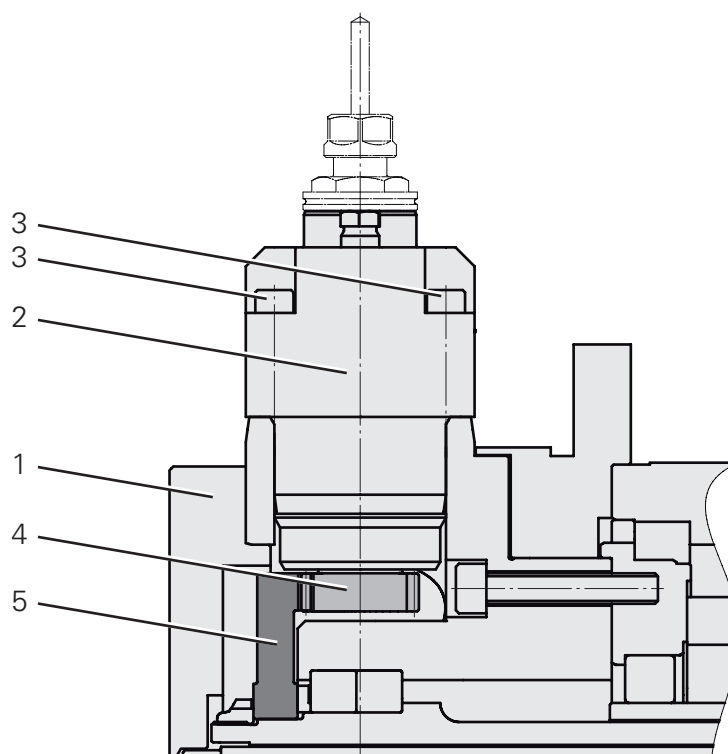

- 1 Turret head
- 2 Tool holder
- 3 Mounting screws
- 4 Drive gear
- 5 Crown wheel

### **Tool Drive on the Tool Turret**

All 8 tool stations on the upper turret and all 7 tool stations on the lower turret can be live.

The tool drive is designed as an overall drive consisting essentially of an AC motor, a drive shaft with a crown wheel, and a controller.

The tool drive's AC motor is designed for heavy duty cutting at low speeds and high torque.

For higher speeds at which lower torques are required, the transmission occurs inside the tool holders.

The counter spindle with a tool turret is live by the same motor as for the tool drive, and it is programmed that way.

The tool turret can be swiveled with the H axis while the tool drive is running.

Thanks to the overall drive, the drive shaft need not be disengaged/engaged from/with the tool holders and accelerated/decelerated.

This makes it possible to swivel the turret head with the H axis while the drive is running.

Depending on the direction of swivel or rotation, the speed is shortly increased or decreased when swiveling the turret.

When swiveling from station to station, the tool drive should not be operated at maximum speed in order to limit the load on the tool holders.

The drive pinion speed can be programmed in a range of 0 to 12,000 rpm via the AC-controlled 3-phase motor.

### **Dry Run for Live Tool Holders**

During setup and automatic mode, make sure that the tooling holder's sealing point at the cooling lubricant transfer is always wet with cooling lubricant.

Tool holders may be operated without cooling lubricant during setup only for a short time. During this time, the leakage of the adding valves and the reserves in the supply line are used for lubrication.

For the rear end machining unit, all tool holders are live simultaneously by the overall drive. This means that unused tool holders must also be supplied with cooling lubricant for a short time.

Therefore, all unused live tool holders should be removed and the corresponding tool receptacle should be closed with blanking plugs.

### Cleaning the tool drive

On the upper and lower tool turrets



When cleaning the tool drive inside the turret head, the flange must not be removed, because otherwise the machine needs to be readjusted.

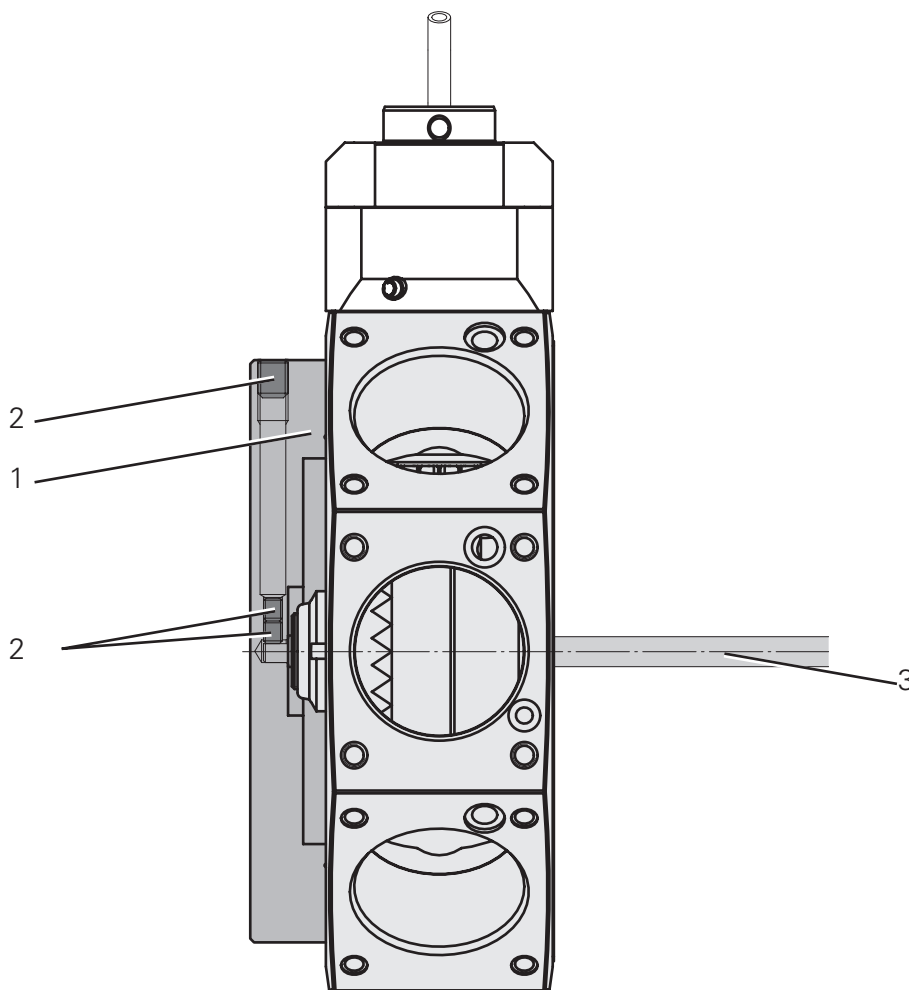

- 1 Flange
- 2 Sealed screw
- 3 Measuring bar

### Blanking plug



The machine may be operated only when all unused tool stations are closed with blanking plugs.



The blanking plugs are not included in the delivery and must be ordered separately.

on the tool turret

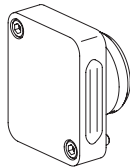

### **WFB Interface, Mounting**

First tighten a threaded taper pin by loosening and retightening it 1-2 times. This results in optimum positioning of the components. Now tighten the second threaded taper pin (in the same way as above). For the recommended torques, please see the table below.

### **WFB interface, service and maintenance**

The surfaces of the faces, taper bore and tapers must be cleaned and covered with an oil lubricating film. For best fastening results and to ensure that the threaded taper pins can easily be loosened, it is recommended to apply Molykote 1000 or a similar hot screw compound to the threaded taper pins.

### **WFB interface, tightening torques**

Recommended tightening torques		
Size	Threaded taper pin	Tightening torque
WFB 20-12	M6x1	4 Nm
WFB 24-16	M8x1	10 Nm
WFB 32-20	M10x1	20 Nm
WFB 40-25	M12x1	25 Nm
WFB 50-32	M14x1	30 Nm

Recommended tightening torques when using mandrel gauges		
Size	Threaded taper pin	Tightening torque
WFB 20-12	M6x1	5 Nm
WFB 24-16	M8x1	5 Nm
WFB 32-20	M10x1	10 Nm
WFB 40-25	M12x1	10 Nm
WFB 50-32	M14x1	15 Nm



## **Usage Information**

### **TRAUB TNL 18-9**

## Modular system of the TRAUB TNL 18-9

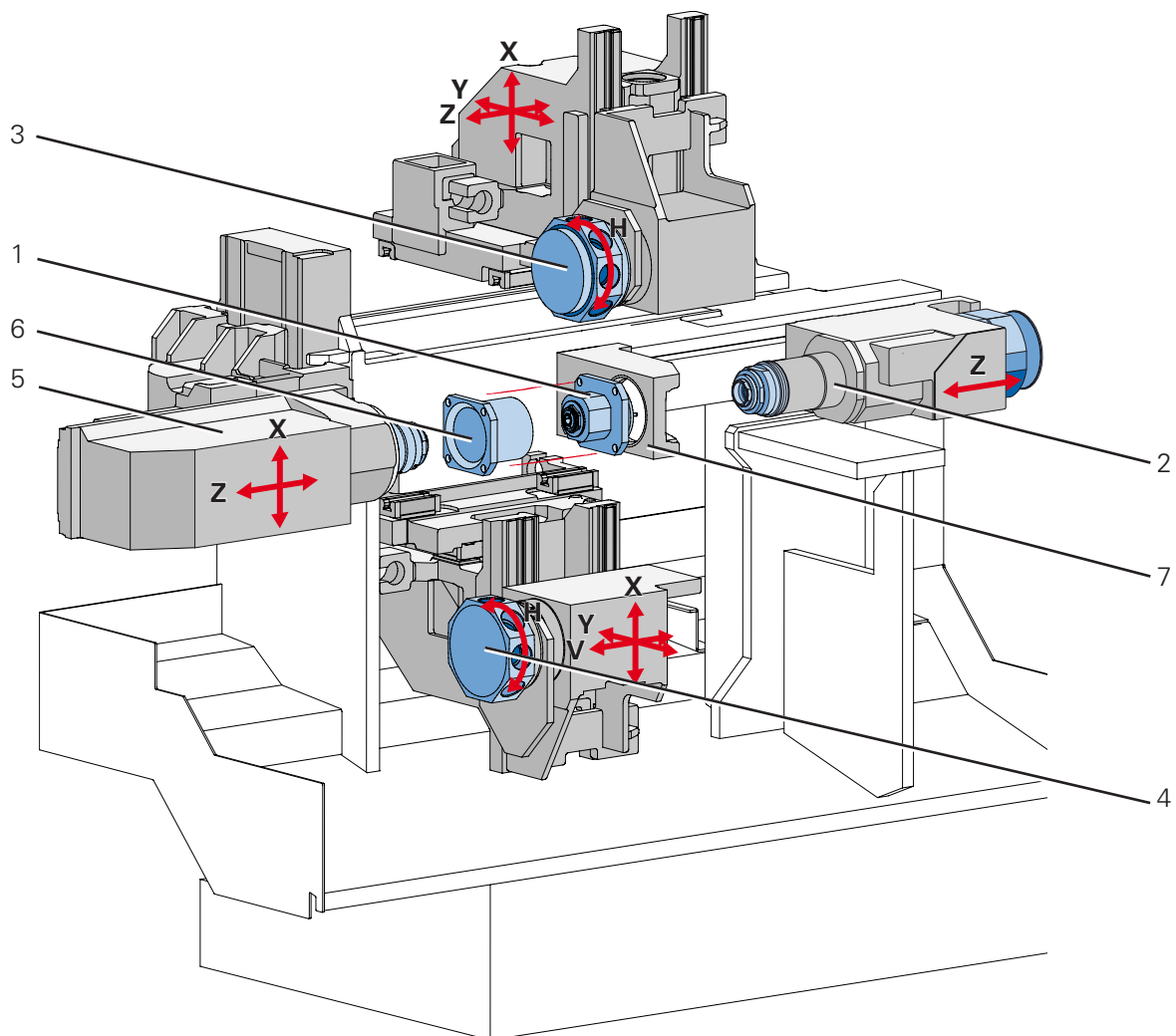

- 1 Guide bushing unit
- 2 Main spindle - Z
- 3 Turret top - XYZH
- 4 Turret bottom - XYVH

- 5 Counter spindle - XZ
- 6 Guide bushing
- 7 Guide bushing carrier



Work area TRAUB TNL 18-9

Fixed headstock turning

- ⊕ T = tool holder zero
- ⊕ B = reference point
- R = Reference point
- ⊕ M = machine zero point

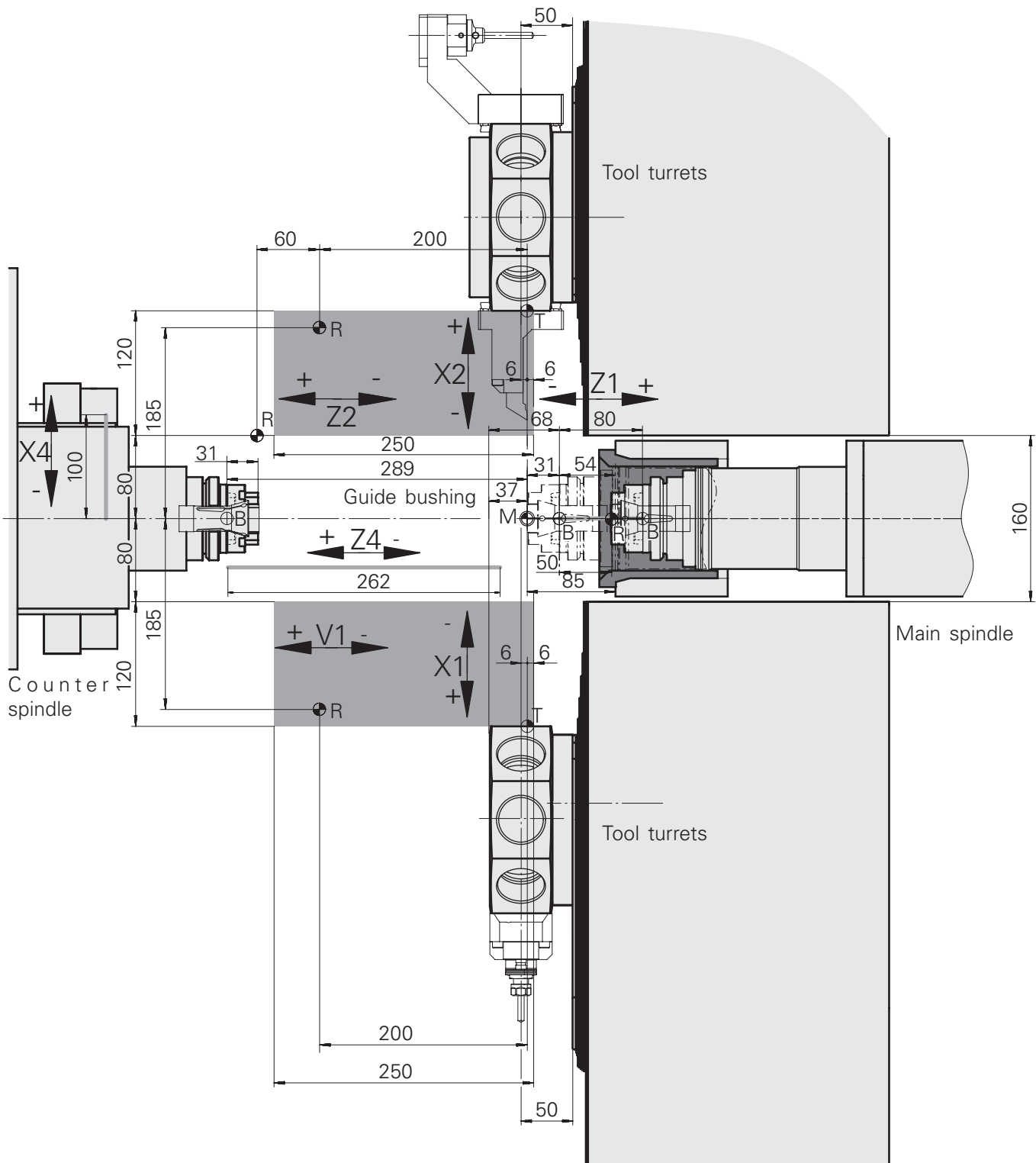

Work area TRAUB TNL 18-9

Sliding headstock turning

- ⊕ T = tool holder zero
- ⊕ B = reference point
- ⊕ M = machine zero point

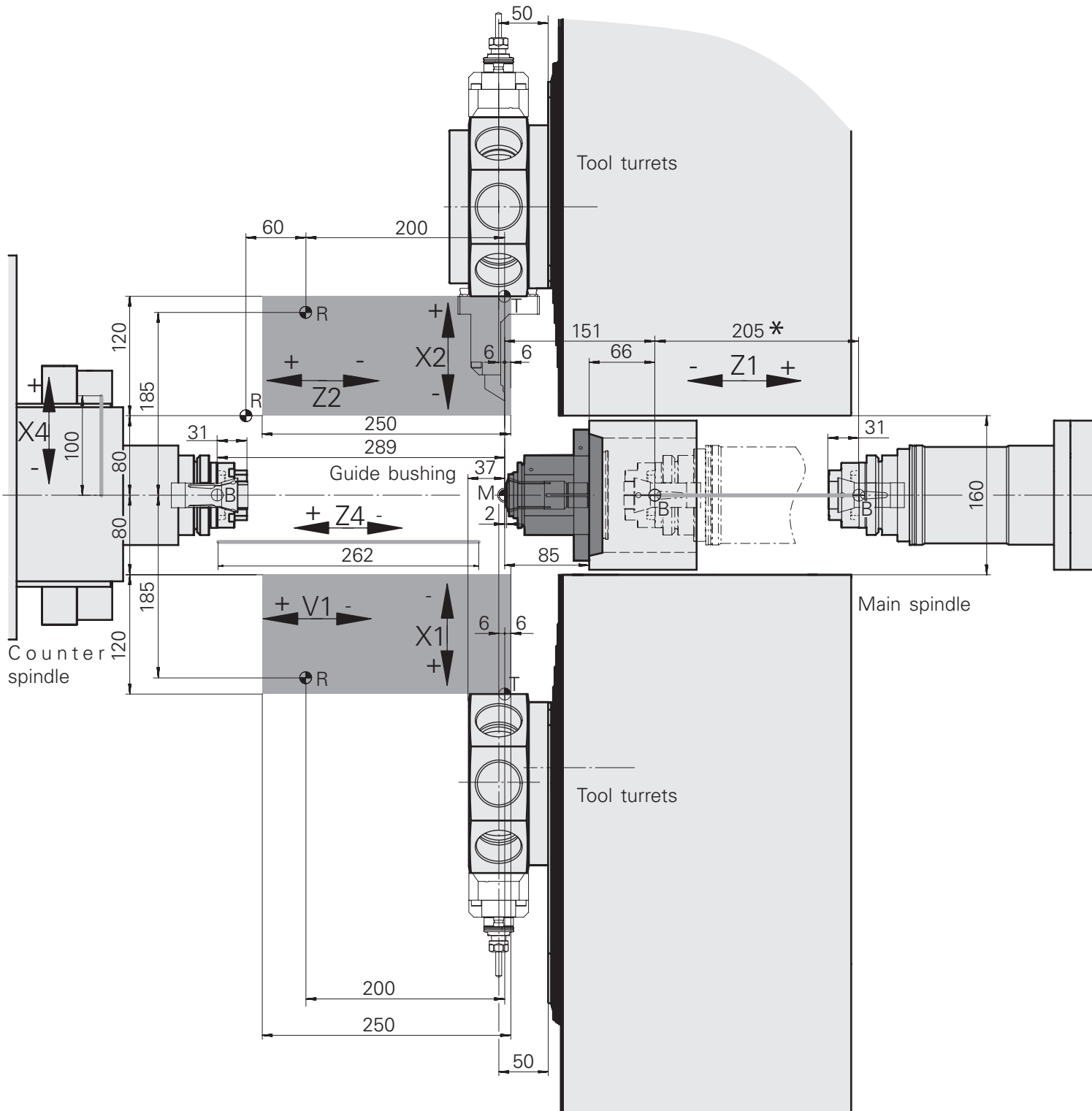

\*The stroke depends on the clamping device (Z1)

Work area TRAUB TNL 18-9

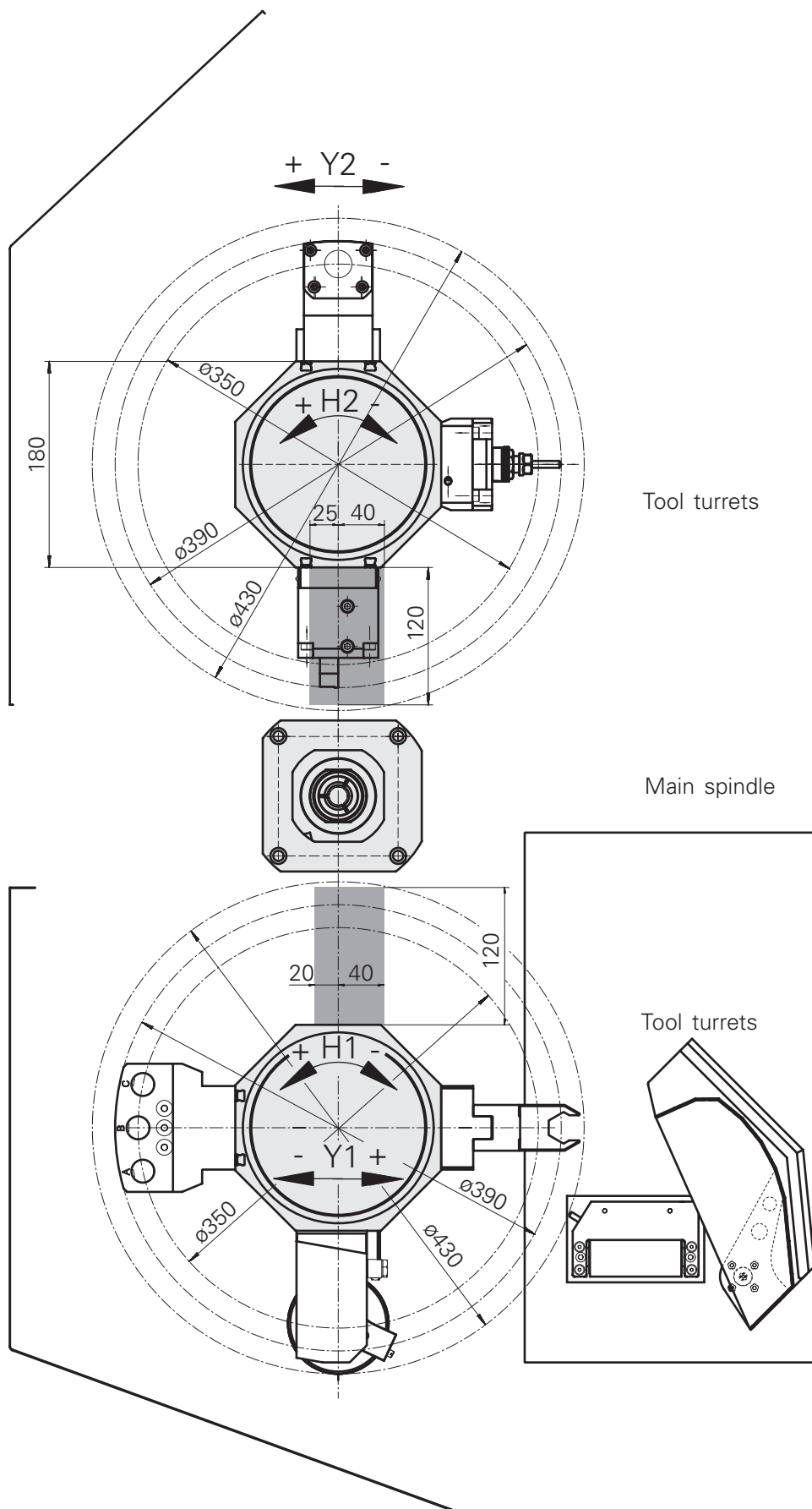

## Performance chart

Driven tools  
Bottom tool turret

 For information on how to use the diagram, see Chapter "Technical Information."

Speed range 0-12000 rpm

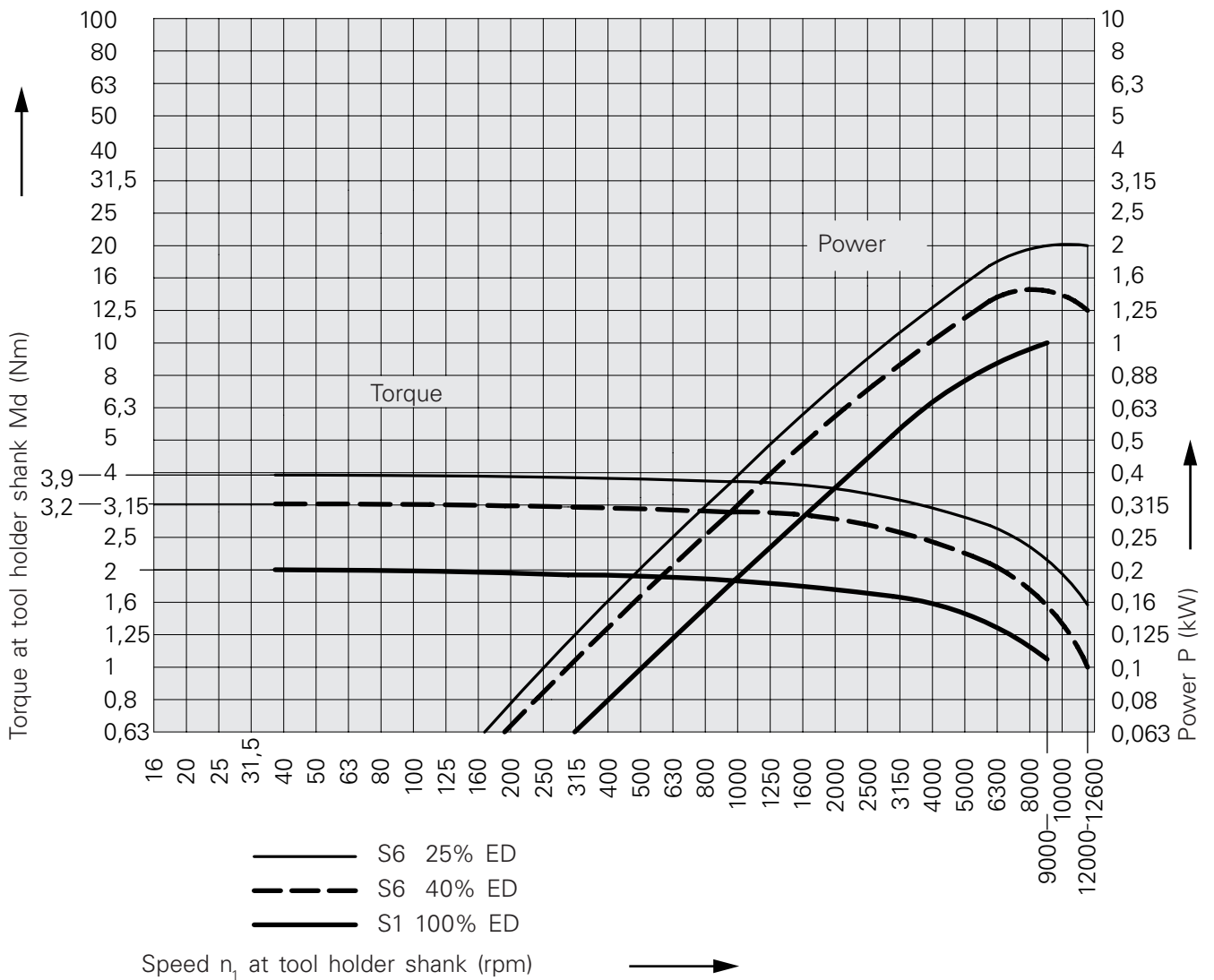

## Performance chart

Driven tools  
Top tool turret

 For information on how to use the diagram, see Chapter "Technical Information."

Speed range 0-12000 rpm

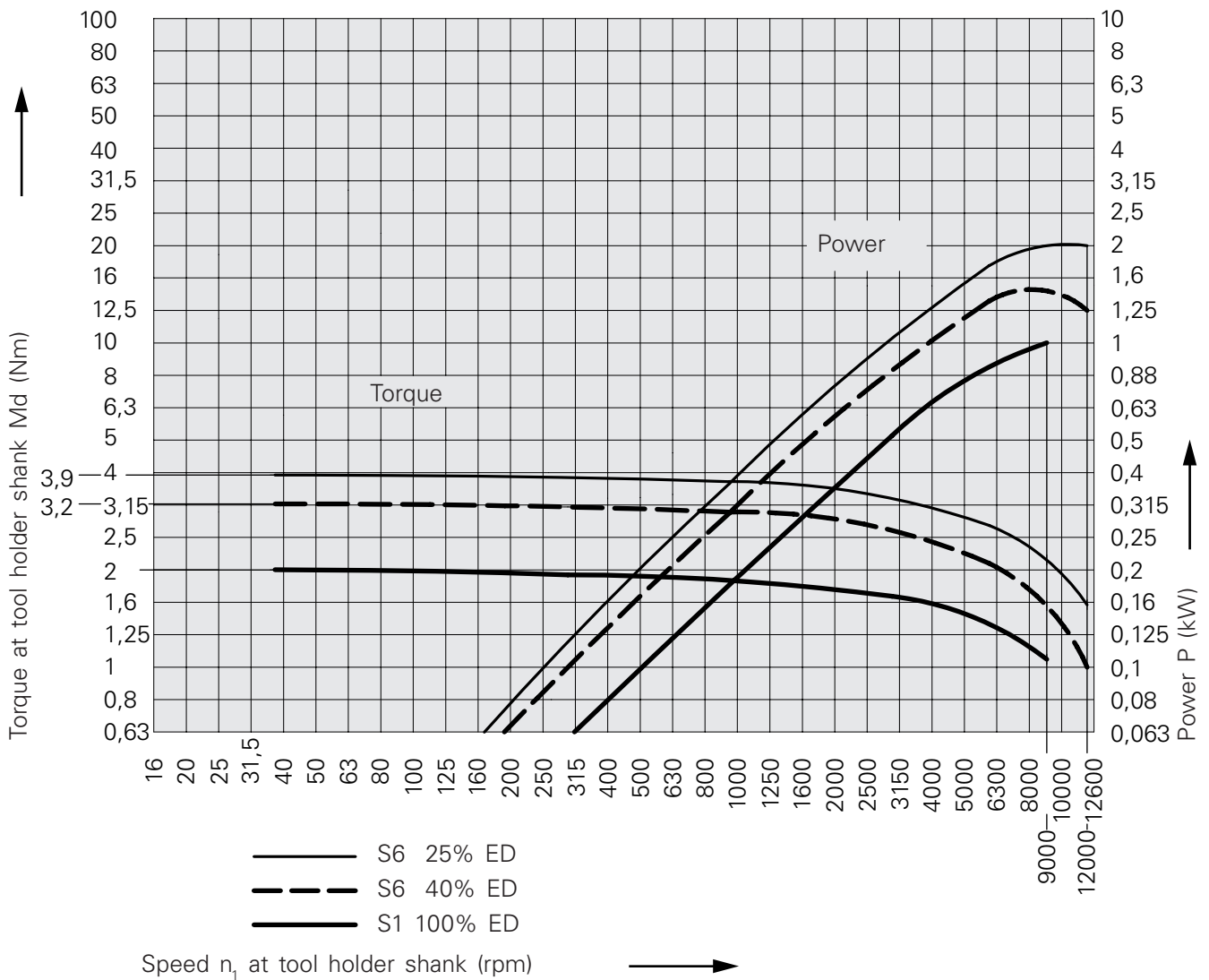

## Quick-Change Insert WFB

Operating Instructions  
2-piece shrink fit chuck

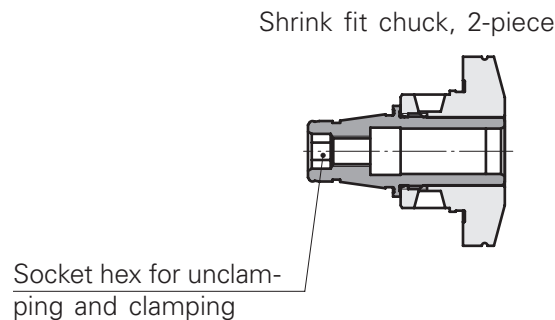
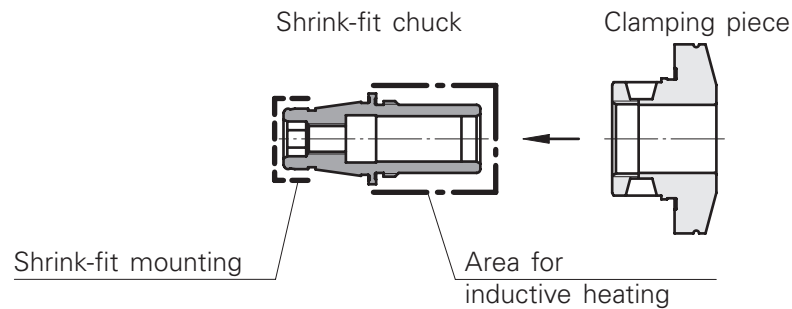

### Working Principle

- 1) Remove the 2-piece shrink-fit chuck.  
Only the socket hex inside the shrink-fit chuck may be used for unclamping and clamping.
- 2) Accept the shrink-fit chuck into the basic mounting (collet chuck) on the clamping collar.
- 3) Use induction heating and shrink-fit cutting tool.
- 4) Let the shrink-fit chuck cool down.
- 5) Mount the clamping piece and shrink-fit chuck as a unit.

### Cleaning

After several shrink-fit cycles, the cylindrical section of the shrink-fit chuck should be cleaned with steel wool or the like.



Short type WFB shrink-fit chucks consist of the actual shrink-fit chuck and the clamping piece. The two parts are supplied assembled and bear the same label.

Only parts with identical labels may be assembled as a 2-piece shrink-fit chuck.









# INDEX



**INDEX-Werke GmbH & Co. KG  
Hahn & Tessky**  
Plochinger Straße 92  
D-73730 Esslingen, Germany  
[www.index-werke.de](http://www.index-werke.de)

**TRAUB-Drehmaschinen  
GmbH & Co. KG**  
Hauffstraße 4  
D-73262 Reichenbach, Germany  
[www.traub.de](http://www.traub.de)

**TECHNICAL ADVICE**  
Phone +49 (0) 711 3191-9854  
Fax +49 (0) 711 90129-343  
[werkzeughalter@traub.de](mailto:werkzeughalter@traub.de)

**TECHNICAL ADVICE**  
Phone +49 (0) 7153 502-9854  
Fax +49 (0) 711 90129-343  
[werkzeughalter@traub.de](mailto:werkzeughalter@traub.de)

**SPARE PARTS SALE**  
Phone +49 (0) 711 3191-600  
Fax +49 (0) 711 3191-790  
[ersatzteile@index-werke.de](mailto:ersatzteile@index-werke.de)

**SPARE PARTS SALE**  
Phone +49 (0) 7153 502-600  
Fax +49 (0) 7153 502-685  
[ersatzteile@traub.de](mailto:ersatzteile@traub.de)

# Tool Holder Catalog

**TRAUB TNL 18P**

**TRAUB TNL 18-7**

**TRAUB TNL 18-7B**

**TRAUB TNL 18-9**

Tool holder

Quick-change inserts

Accessories

Product information

## **Disclaimer**

The illustrations in this documents may deviate from the delivered product. We reserve the right to make changes due to errors or based on technical advances.

## **Abbreviations used in the catalog:**

EC = external cooling lubricant supply

approx.= approximately

D = diameter

max = maximum

min = minimum

IC = internal cooling lubricant supply

MT = Morse taper

R = radius

s = wrench size

ST = steep taper

SQ = square

## **A word on copyright**

This document is proprietary and was originally written in German. Its reproduction and distribution in whole or in individual parts without permission of the copyright owner is prohibited and will be prosecuted under criminal or civil law. All rights reserved, including for translation.

© Copyright by INDEX-Werke GmbH & Co. KG Esslingen 2014

© Copyright by TRAUB Drehmaschinen GmbH & Co. KG Reichenbach 2014

---

<b>Table of contents</b> .....	<b>0</b>
<b>Technical Information TRAUB TNL 18</b> .....	<b>1</b>
<b>Usage information TRAUB TNL 18</b> .....	<b>2</b>
<b>Stationary tool holder, turret head</b> .....	<b>3</b>
<b>Live tool holder, turret head</b> .....	<b>4</b>
<b>Stationary tool holder, rear end machining unit</b> .....	<b>5</b>
<b>Live tool holder, rear end machining unit</b> .....	<b>6</b>
<b>Accessories – Quick-change inserts</b> .....	<b>7</b>
<b>Accessories – TRAUB TNL 18</b> .....	<b>8</b>
<b>Product information</b> .....	<b>9</b>

**For accessories for tool holders visit <http://infoshop.index-werke.de/>**



## **Table of Contents**





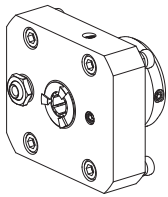

**W7040050 Drilling tool holder**

**3-2**

**Mounting** ER 16  
**Cooling** external and internal,  $p_{max}$  80 bar  
**X / Y / Z** 20 (0.79) / - / - mm (")

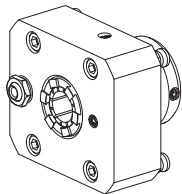

**W7040051 Drilling tool holder**

**3-3**

**Mounting** ER 25  
**Cooling** external and internal,  $p_{max}$  80 bar  
**X / Y / Z** 30 (1.18) / - / - mm (")

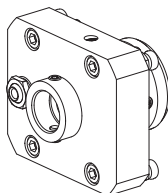

**W7040052 Drilling tool holder**

**3-4**

**Mounting** WFB 20-12  
**Cooling** external and internal,  $p_{max}$  80 bar  
**X / Y / Z** 20 (0.79) / - / - mm (")

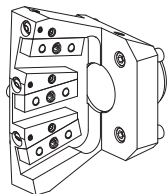

**W7040012 Turning tool holder, triple**

**3-5**

**Mounting** Square 12x12  
**Cooling** external,  $p_{max}$  10 bar  
**X / Y / Z** 85 (3.35) /  $\pm 13^\circ$  / -10 (-0.39) mm (")

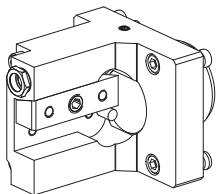

**W7040024 Turning tool holder**

**3-6**

**Mounting** square 16x16  
**Cooling** external,  $p_{max}$  80 bar  
**X / Y / Z** 79 (3.11) / - / -14 (-0.55) mm (")

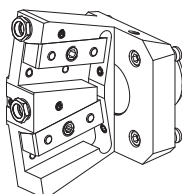

**W7040027 Turning tool holder, double**

**3-7**

**Mounting** square 16x16  
**Cooling** external,  $p_{max}$  80 bar  
**X / Y / Z** 84 (3.31) /  $\pm 10^\circ$  / -14 (-0.55) mm (")

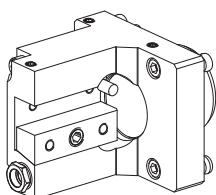

**W7040038 Turning tool holder, left-handed run**

**3-8**

**Mounting** square 16x16  
**Cooling** external,  $p_{max}$  80 bar  
**X / Y / Z** 79 (3.11) / - / -14 (-0.55) mm (")

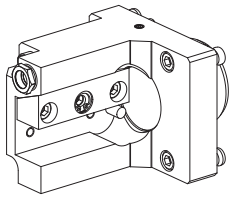

**W7040043 Turning tool holder**

3-9

**Mounting** square 20x20  
**Cooling** external,  $p_{max}$  80 bar  
**X / Y / Z** 85 (3.35) / - / -19 (-0.75) mm (")

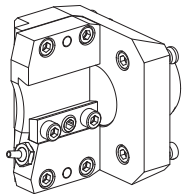

**W7040017 Grooving tool holder**

3-10

**Mounting** Trapezoid 26x8  
**Cooling** external,  $p_{max}$  80 bar  
**X / Y / Z** 68 (2.68) / - / -6 (-0.24) mm (")

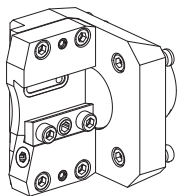

**W7040096 Grooving tool holder**

3-11

**Mounting** Trapezoid 26x8  
**Cooling** external and internal,  $p_{max}$  80 bar  
**X / Y / Z** 68 (2.68) / - / 6 (0.24) mm (")

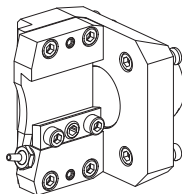

**W7040048 Grooving tool holder**

3-12

**Mounting** Trapezoid 32x8  
**Cooling** external,  $p_{max}$  80 bar  
**X / Y / Z** 68 (2.68) / - / -6 (-0.24) mm (")

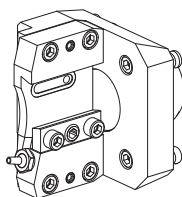

**W7040097 Grooving tool holder**

3-13

**Mounting** Trapezoid 32x8  
**Cooling** external and internal,  $p_{max}$  80 bar  
**X / Y / Z** 68 (2.68) / - / 6 (0.24) mm (")

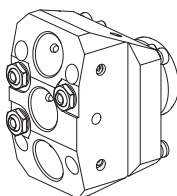

**W7040057 Basic holder, triple**

3-14

**Mounting** D24  
**Cooling** external and internal,  $p_{max}$  80 bar  
**X / Y / Z** 52 (25) /  $\pm 13^\circ$  / 0 mm (")

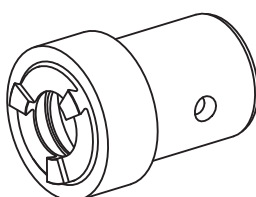

**W9990703 Mount**

3-15

**Mounting** ER 16  
**Cooling** internal,  $p_{max}$  80 bar  
**X / Y / Z** 12 (0.47) / - / - mm (")

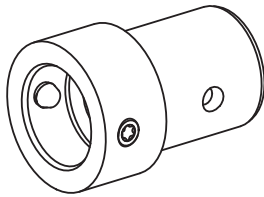

**W9990704 Mount**

**3-16**

**Mounting** WFB 20-12  
**Cooling** internal,  $p_{max}$  80 bar  
**X / Y / Z** 15 (0.59) / - / - mm (")

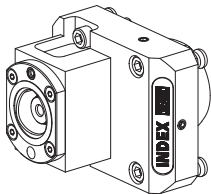

**W7040091 Basic holder**

**3-17**

**Mounting** INDEX TRAUB CAPTO C3  
**Cooling** internal,  $p_{max}$  80 bar  
**X / Y / Z** 57 (2.24) / - / 16 (0.63) mm (")

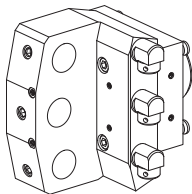

**W7040014 Basic holder, triple**

**3-18**

**Mounting** D20  
**Cooling** external, internal optional,  $p_{max}$  80 bar  
**X / Y / Z** 85 (3.35) /  $\pm 12.5^\circ$  / 16 (0.63) mm (")

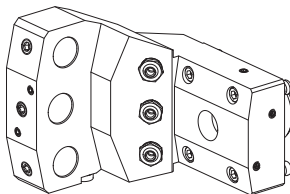

**W7040069 Basic holder, triple**

**3-19**

**Mounting** D20  
**Cooling** external, internal optional,  $p_{max}$  80 bar, internal 160 bar optional  
**X / Y / Z** 85 (3.35) /  $\pm 12.5^\circ$  / -82 (-3.23) mm (")

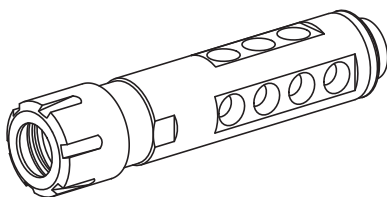

**W9990344 Mount**

**3-20**

**Mounting** ER 16  
**Cooling** internal,  $p_{max}$  80 bar  
**X / Y / Z** - / - / - mm (")

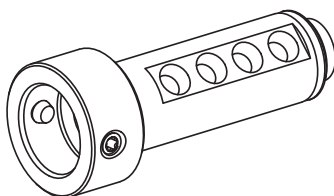

**W9990107 Mount**

**3-21**

**Mounting** WFB 20-12  
**Cooling** internal,  $p_{max}$  80 bar  
**X / Y / Z** - / - / - mm (")

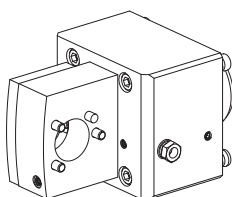

**W7040015 Basic holder**

**3-22**

**Mounting** D24  
**Cooling** external and internal,  $p_{max}$  80 bar  
**X / Y / Z** 85 (3.35) / - / 16 (0.63) mm (")

Catalog page

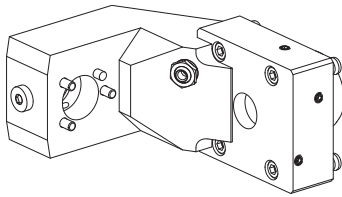

**W7040087 Basic holder**

**3-23**

**Mounting** D24  
**Cooling** external and internal,  $p_{max}$  80 bar  
**X / Y / Z** 85 (3.35) / - / -71 (-2.8) mm (")

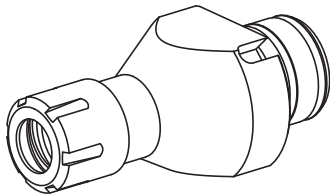

**W9990346 Mount**

**3-24**

**Mounting** ER 16  
**Cooling** internal,  $p_{max}$  80 bar  
**X / Y / Z** 54 (2.13) / - / - mm (")

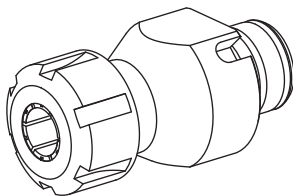

**W9990541 Mount**

**3-25**

**Mounting** ER 20  
**Cooling** internal,  $p_{max}$  80 bar  
**X / Y / Z** 54 (2.13) / - / - mm (")

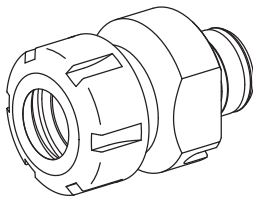

**W9990562 Mount**

**3-26**

**Mounting** ER 25  
**Cooling** internal,  $p_{max}$  80 bar  
**X / Y / Z** 47 (1.85) / - / - mm (")

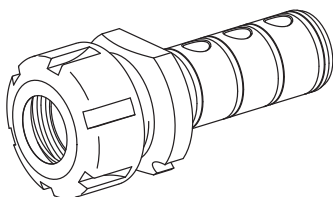

**W9990575 Mount**

**3-27**

**Mounting** ER 25  
**Cooling** internal,  $p_{max}$  80 bar  
**X / Y / Z** - / - / - mm (")

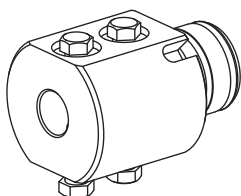

**W9990530 Mount**

**3-28**

**Mounting** D12  
**Cooling** internal,  $p_{max}$  80 bar  
**X / Y / Z** 36 (1.42) / - / - mm (")

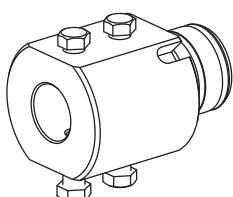

**W9990105 Mount**

**3-29**

**Mounting** D16  
**Cooling** internal,  $p_{max}$  80 bar  
**X / Y / Z** 36 (1.42) / - / - mm (")

Catalog page  
**3-30**

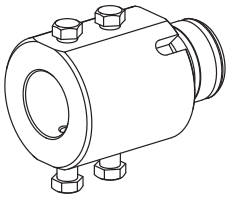

**W9990506 Mount**

**Mounting** D20  
**Cooling** internal,  $p_{max}$  80 bar  
**X / Y / Z** 40 (1.57) / - / - mm (")

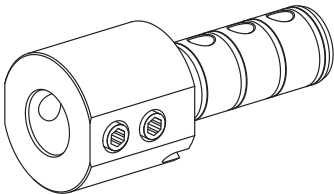

**W9990577 Mount**

**3-31**

**Mounting** D20  
**Cooling** internal,  $p_{max}$  80 bar  
**X / Y / Z** - / - / - mm (")

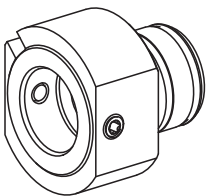

**W9990106 Mount**

**3-32**

**Mounting** WFB 20-12  
**Cooling** internal,  $p_{max}$  80 bar  
**X / Y / Z** 19 (0.75) / - / - mm (")

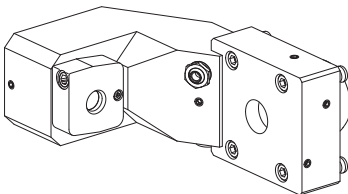

**W7040083 Basic holder**

**3-33**

**Mounting** Hydraulic expansion chuck D12  
**Cooling** external and internal,  $p_{max}$  80 bar, internal 160 bar optional  
**X / Y / Z** 85 (3.35) / - / -75 (2.95) mm (")

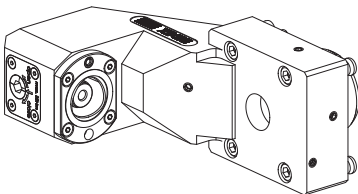

**W7040092 Basic holder**

**3-34**

**Mounting** INDEX TRAUB CAPTO C3  
**Cooling** internal,  $p_{max}$  120 bar  
**X / Y / Z** 85 (3.35) / - / -71 (-2.8) mm (")

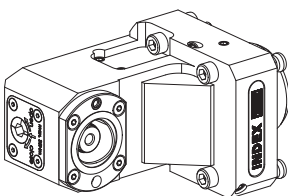

**W7040093 Basic holder**

**3-35**

**Mounting** INDEX TRAUB CAPTO C3  
**Cooling** internal,  $p_{max}$  120 bar  
**X / Y / Z** 85 (3.35) / - / 6 (0.24) mm (")

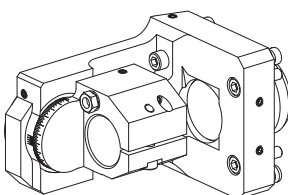

**W7040023 Basic holder, angle-adjustable**

**3-36**

**Mounting** D28  
**Cooling** external,  $p_{max}$  80 bar  
**X / Y / Z** 98 (3.86) / - / - mm (")

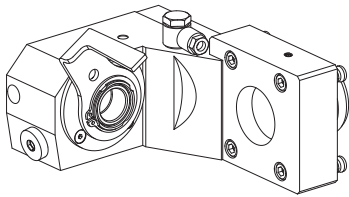

**W7040010 Closing tool holder, for rolling head of Fette**

**3-37**

**Mounting** D3/4"/D25  
**Cooling** external, p<sub>max</sub> 80 bar  
**X / Y / Z** 81 (3.19) / – / -63 (-2.48) mm (")

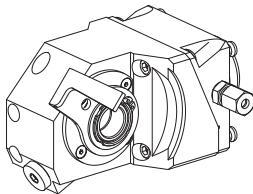

**W7040011 Closing tool holder, for rolling head of Fette**

**3-38**

**Mounting** D3/4"/D25  
**Cooling** external, p<sub>max</sub> 80 bar  
**X / Y / Z** 81 (3.19) / – / 22.5 (0.89) mm (")

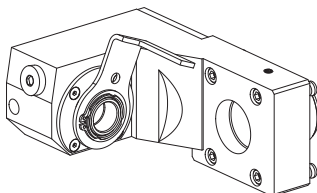

**W7040034 Closing tool holder, for rolling head of Wagner**

**3-39**

**Mounting** D3/4"/D25  
**Cooling** external, p<sub>max</sub> 80 bar  
**X / Y / Z** 81 (3.19) / – / -63 (-2.48) mm (")

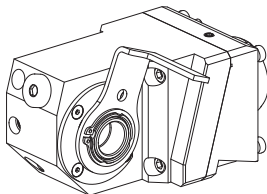

**W7040074 Closing tool holder, for rolling head of Wagner**

**3-40**

**Mounting** D3/4"/D25  
**Cooling** external, p<sub>max</sub> 80 bar  
**X / Y / Z** 96 (3.78) / – / 28 (1.10) mm (")

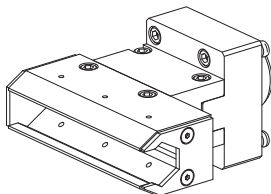

**W7040013 Receiving tray**

**3-41**

**Mounting** –  
**Cooling** –  
**X / Y / Z** 121 (4.76) / – / 80.5 (3.17) mm (")

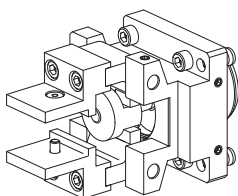

**W7040021 Gripper**

**3-42**

**Mounting** –  
**Cooling** –  
**X / Y / Z** 102 (42) / – / – mm (")

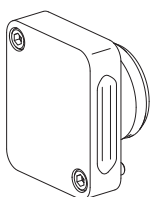

**W9990770 Blanking plug, Plastic**

**3-43**

**Mounting** –  
**Cooling** –  
**X / Y / Z** 18 (0.71) / – / 0 mm (")

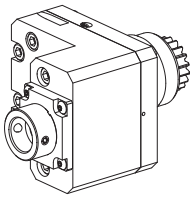

**W7045035 Drilling unit**

4-2

<b>Mounting</b>	WFB 20-12
<b>Cooling</b>	external, $p_{max}$ 80 bar
<b>Speed ratio</b>	1:2.53 (0.395)
<b>X / Y / Z</b>	84 (3.31) / – / 30 (1.18) mm (")

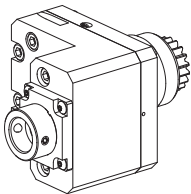

**W7045039 Drilling unit**

4-3

<b>Mounting</b>	WFB 20-12
<b>Cooling</b>	external, $p_{max}$ 80 bar, internal 160 bar optional
<b>Speed ratio</b>	1:2.53 (0.395)
<b>X / Y / Z</b>	84 (3.31) / – / 30 (1.18) mm (")

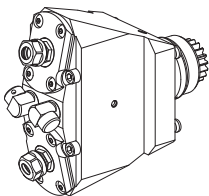

**W7045002 Milling unit, double**

4-4

<b>Mounting</b>	ER 11
<b>Cooling</b>	external, $p_{max}$ 80 bar
<b>Speed ratio</b>	1:1 (1)
<b>X / Y / Z</b>	102.5 (44) / $\pm 13^\circ$ / – mm (")

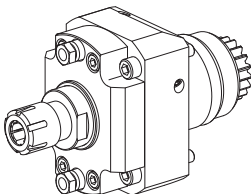

**W7045018 Milling unit**

4-5

<b>Mounting</b>	ER 16
<b>Cooling</b>	external, $p_{max}$ 80 bar
<b>Speed ratio</b>	1:1 (1)
<b>X / Y / Z</b>	79 (3.11) / – / – mm (")

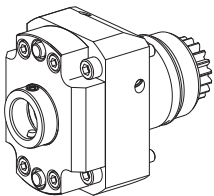

**W7045001 Milling unit**

4-6

<b>Mounting</b>	WFB 20-12
<b>Cooling</b>	external, $p_{max}$ 80 bar
<b>Speed ratio</b>	1:1 (1)
<b>X / Y / Z</b>	54 (2.13) / – / – mm (")

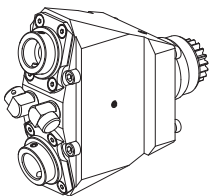

**W7045048 Milling unit, double**

4-7

<b>Mounting</b>	WFB 20-12
<b>Cooling</b>	external, $p_{max}$ 80 bar
<b>Speed ratio</b>	1:1 (1)
<b>X / Y / Z</b>	102 (42) / $\pm 13^\circ$ / 0 mm (")

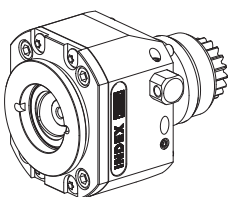

**W7045086 Milling unit**

4-8

<b>Mounting</b>	INDEX TRAUB CAPTO C3
<b>Cooling</b>	external, $p_{max}$ 80 bar
<b>Speed ratio</b>	1:1 (1)
<b>X / Y / Z</b>	56 (2.2) / – / 0 mm (")

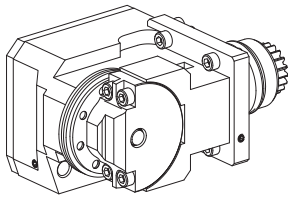

**W7045005 Circular saw unit**

4-9

<b>Mounting</b>	Milling tool mounting D22
<b>Cooling</b>	external, $p_{\max}$ 80 bar
<b>Speed ratio</b>	8.1:1 (8.1)
<b>X / Y / Z</b>	81.5 (3.21) / - / 4 (0.16) mm (")

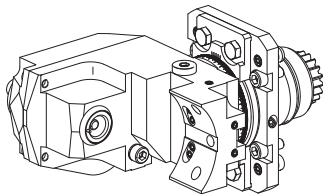

**W7045021 Gear cutting unit**

4-10

<b>Mounting</b>	-
<b>Cooling</b>	external, $p_{\max}$ 80 bar
<b>Speed ratio</b>	3:1 (3)
<b>X / Y / Z</b>	92 (3.62) / - / - mm (")

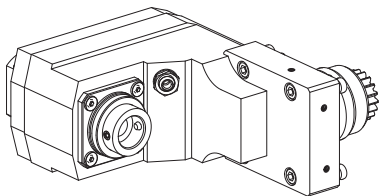

**W7045098 Drilling unit**

4-11

<b>Mounting</b>	WFB 20-12
<b>Cooling</b>	external, internal optional, $p_{\max}$ 160 bar
<b>Speed ratio</b>	1:1.66 (0.6)
<b>X / Y / Z</b>	95 (3.74) / - / -40 (-1.57) mm (")

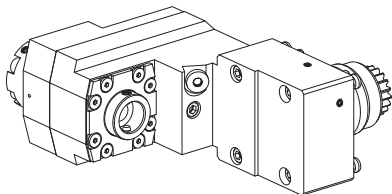

**W7045014 Drilling unit**

4-12

<b>Mounting</b>	WFB 20-12
<b>Cooling</b>	external, $p_{\max}$ 80 bar, internal 160 bar optional
<b>Speed ratio</b>	1:1 (1)
<b>X / Y / Z</b>	95 (3.74) / - / -60 (-2.36) mm (")

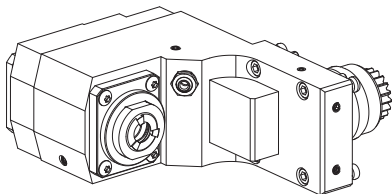

**W7045074 Milling unit**

4-13

<b>Mounting</b>	ER 16
<b>Cooling</b>	external and internal, $p_{\max}$ 80 bar
<b>Speed ratio</b>	1:1 (1)
<b>X / Y / Z</b>	95 (3.74) / - / -40 (-1.57) mm (")

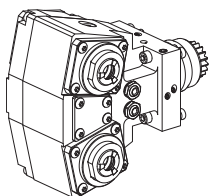

**W7045101 Milling unit, double**

4-14

<b>Mounting</b>	ER 16
<b>Cooling</b>	external, internal optional, $p_{\max}$ 80 bar
<b>Speed ratio</b>	1:1 (1)
<b>X / Y / Z</b>	95 (3.74) / $\pm 13^\circ$ / 55 (2.17) mm (")

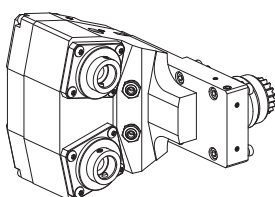

**W7045049 Milling unit, double**

4-15

<b>Mounting</b>	WFB 20-12
<b>Cooling</b>	external, internal optional, $p_{\max}$ 80 bar
<b>Speed ratio</b>	1:1.08 (0.93)
<b>X / Y / Z</b>	95 (3.74) / $\pm 13^\circ$ / -37 (-1.46) mm (")



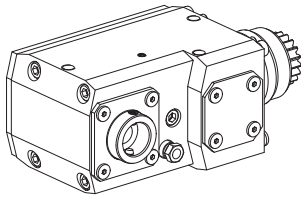

**W7045024 Milling unit**

**4-16**

<b>Mounting</b>	WFB 20-12
<b>Cooling</b>	external, $p_{\max}$ 80 bar
<b>Speed ratio</b>	1:1 (1)
<b>X / Y / Z</b>	95 (3.74) / – / 44 (1.73) mm (")

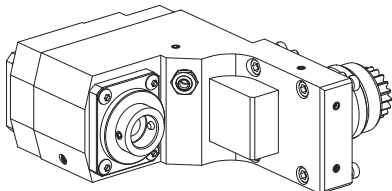

**W7045058 Milling unit**

**4-17**

<b>Mounting</b>	WFB 20-12
<b>Cooling</b>	external and internal, $p_{\max}$ 80 bar
<b>Speed ratio</b>	1:1 (1)
<b>X / Y / Z</b>	95 (3.74) / – / -37 (-1.46) mm (")

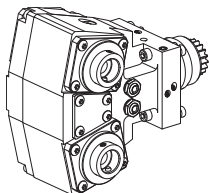

**W7045099 Milling unit, double**

**4-18**

<b>Mounting</b>	WFB 20-12
<b>Cooling</b>	external, internal optional, $p_{\max}$ 80 bar
<b>Speed ratio</b>	1:1 (1)
<b>X / Y / Z</b>	95 (3.74) / $\pm 13^\circ$ / 58 (2.28) mm (")

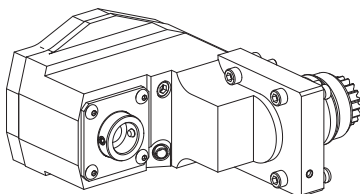

**W7045004 Milling unit**

**4-19**

<b>Mounting</b>	WFB 20-12
<b>Cooling</b>	external, $p_{\max}$ 80 bar
<b>Speed ratio</b>	3:1 (3)
<b>X / Y / Z</b>	95 (3.74) / – / -37 (-1.46) mm (")

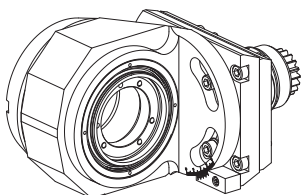

**W7045012 Thread whirling unit**

**4-20**

<b>Mounting</b>	–
<b>Cooling</b>	external, $p_{\max}$ 80 bar
<b>Speed ratio</b>	1.97:1 (1.97)
<b>X / Y / Z</b>	80 (3.15) / – / -4.5 (-0.18) mm (")

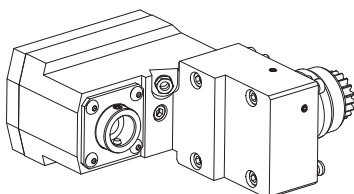

**W7045034 Broaching/ Slotting unit**

**4-21**

<b>Mounting</b>	WFB 20-12
<b>Cooling</b>	external, $p_{\max}$ 80 bar
<b>Speed ratio</b>	1:1 (1)
<b>X / Y / Z</b>	95 (3.74) / – / -37 (-1.46) mm (")

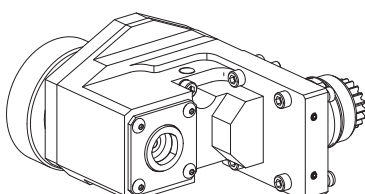

**W7045006 Polygon turning unit**

**4-22**

<b>Mounting</b>	WFK 20-12
<b>Cooling</b>	external, $p_{\max}$ 80 bar
<b>Speed ratio</b>	3:1 (3)
<b>X / Y / Z</b>	85 (3.35) / – / -13.5 (-0.53) mm (")

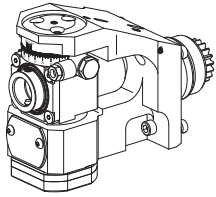

**W7045023 Milling unit, angle-adjustable**

Catalog page

**4-23**

<b>Mounting</b>	WFB 20-12
<b>Cooling</b>	external, $p_{\max}$ 80 bar
<b>Speed ratio</b>	1.03:1 (1.0267)
<b>X / Y / Z</b>	81 (3.19) / 17 (0.67) / – mm (")

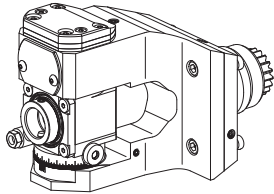

**W7045011 Milling unit, angle-adjustable**

**4-24**

<b>Mounting</b>	WFB 20-12
<b>Cooling</b>	external, $p_{\max}$ 80 bar
<b>Speed ratio</b>	1.15:1 (1.1499)
<b>X / Y / Z</b>	90 mm (3.54 ") / – / 21.5 (0.85) mm (")

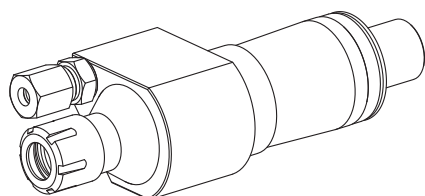

**W7140002 Porte-foret**

5-2

**Attachement** ER 16  
**Arrosage** extérieur, en option central,  $p_{max}$  80 bar, AC optionnel 160 bar  
**X / Y / Z** - / - / 71 mm

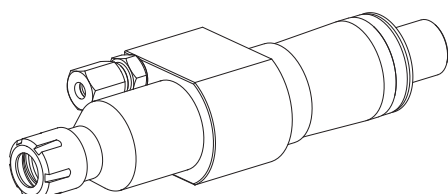

**W7140003 Porte-foret**

5-3

**Attachement** ER 16  
**Arrosage** extérieur, en option central,  $p_{max}$  80 bar, AC optionnel 160 bar  
**X / Y / Z** - / - / 101 mm

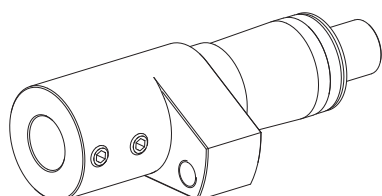

**W7140004 Porte-foret**

5-4

**Attachement** D20  
**Arrosage** extérieur, en option central,  $p_{max}$  80 bar, AC optionnel 160 bar  
**X / Y / Z** - / - / 65 mm

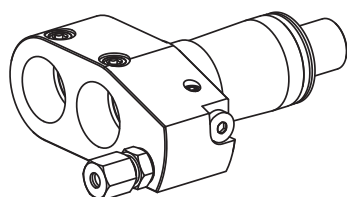

**W7140009 Porte-outil de base, double**

5-5

**Attachement** D25  
**Arrosage** central et extérieur,  $p_{max}$  80 bar, AC optionnel 160 bar  
**X / Y / Z** 35 / 0 + 33 / - mm

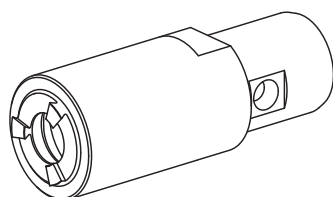

**W9990557 Attachement**

5-6

**Attachement** ER 16  
**Arrosage** central,  $p_{max}$  80 bar  
**X / Y / Z** 50 / - / - mm

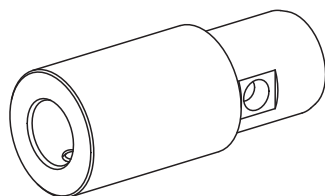

**W9990558 Attachement**

5-7

**Attachement** D16  
**Arrosage** central,  $p_{max}$  80 bar  
**X / Y / Z** 45 / - / - mm

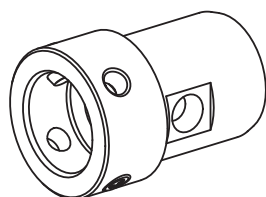

**W9990556 Attachement**

5-8

**Attachement** WFB 20-12  
**Arrosage** central,  $p_{max}$  80 bar  
**X / Y / Z** 15 / - / - mm

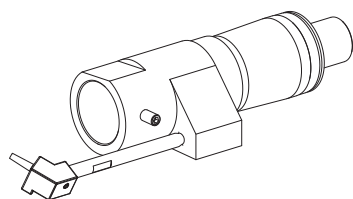

**W7140005 Porte-outil de base**

5-9

**Attachement** D28  
**Arrosage** extérieur,  $p_{max}$  10 bar  
**X / Y / Z** - / - / 54 mm

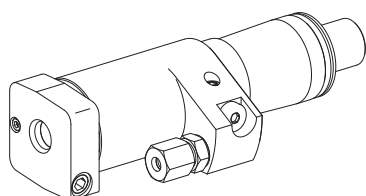

**W7140008 Porte-outil de base**

5-10

**Attachement** Hydroexpansible D12  
**Arrosage** central et extérieur,  $p_{max}$  80 bar, AC optionnel 160 bar  
**X / Y / Z** 85 / - / - mm

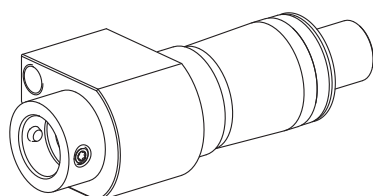

**W7140000 Porte-outil de base**

5-11

**Attachement** WFB 20-12  
**Arrosage** extérieur, en option central,  $p_{max}$  80 bar, AC optionnel 160 bar  
**X / Y / Z** - / - / 50 mm

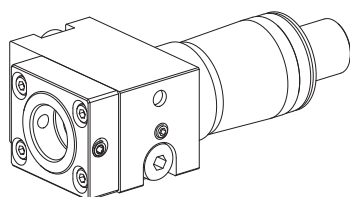

**W7140001 Porte-outil de base, réglable en XY**

5-12

**Attachement** WFB 20-12  
**Arrosage** extérieur, en option central,  $p_{max}$  80 bar, AC optionnel 160 bar  
**X / Y / Z** - / - / 50 mm

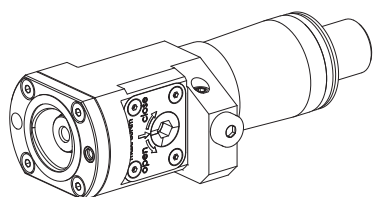

**W7140011 Porte-outil de base**

5-13

**Attachement** INDEX TRAUB CAPTO C3  
**Arrosage** central et extérieur,  $p_{max}$  120 bar  
**X / Y / Z** 60 / - / - mm

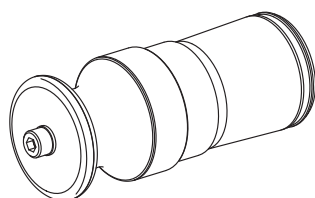

**W9990133 Obturateur, Acier**

5-14

**Attachement** -  
**Arrosage** -  
**X / Y / Z** - / - / 40 mm

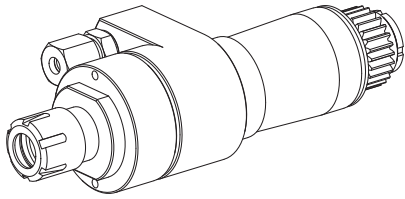

**W7145007 Milling unit**

**6-2**

<b>Mounting</b>	ER 16
<b>Cooling</b>	external, internal optional, $p_{max}$ 80 bar, internal 160 bar optional
<b>Speed ratio</b>	1:1 (1)
<b>X / Y / Z</b>	- / - / 80 (3.15) mm (")

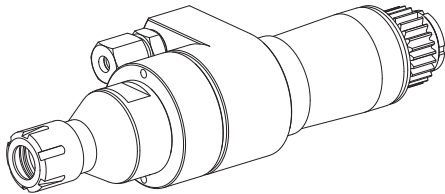

**W7145008 Milling unit**

**6-3**

<b>Mounting</b>	ER 16
<b>Cooling</b>	external, internal optional, $p_{max}$ 80 bar, internal 160 bar optional
<b>Speed ratio</b>	1:1 (1)
<b>X / Y / Z</b>	- / - / 103 (46) mm (")

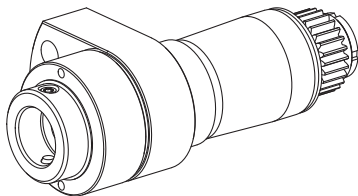

**W7145000 Milling unit**

**6-4**

<b>Mounting</b>	WFB 20-12
<b>Cooling</b>	external, internal optional, $p_{max}$ 80 bar, internal 160 bar optional
<b>Speed ratio</b>	1:1 (1)
<b>X / Y / Z</b>	- / - / 50 (1.97) mm (")

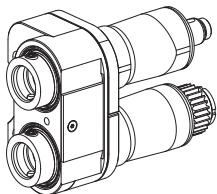

**W7145001 Milling unit, double**

**6-5**

<b>Mounting</b>	WFB 20-12
<b>Cooling</b>	external, internal optional, $p_{max}$ 80 bar, internal 160 bar optional
<b>Speed ratio</b>	1:1 (1)
<b>X / Y / Z</b>	46 (1.81) / - / 50 (1.97) mm (")

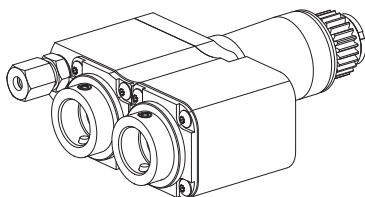

**W7145015 Milling unit, double**

**6-6**

<b>Mounting</b>	WFB 20-12
<b>Cooling</b>	external, internal optional, $p_{max}$ 80 bar, internal 160 bar optional
<b>Speed ratio</b>	1:1 (1)
<b>X / Y / Z</b>	- / 40 (1.57) / 70 (2.76) mm (")

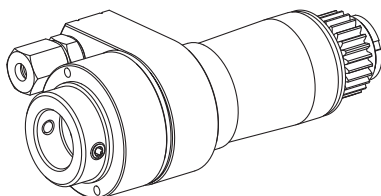

**W7145013 Broaching/ Slotting unit**

**6-7**

<b>Mounting</b>	WFB 20-12
<b>Cooling</b>	external, $p_{max}$ 80 bar
<b>Speed ratio</b>	1:1 (1)
<b>X / Y / Z</b>	- / - / 51 (21) mm (")

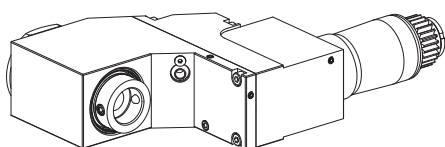

**W7145002 Milling unit**

**6-8**

<b>Mounting</b>	WFB 20-12
<b>Cooling</b>	external, $p_{max}$ 40 bar
<b>Speed ratio</b>	1:1 (1)
<b>X / Y / Z</b>	26 (12) / - / 110 (4.33) mm (")

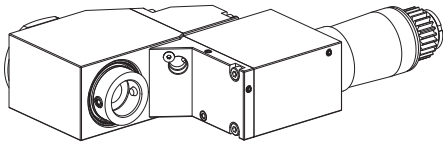

**W7145009 Milling unit**

6-9

<b>Mounting</b>	WFB 20-12
<b>Cooling</b>	external, $p_{\max}$ 40 bar
<b>Speed ratio</b>	1:1 (1)
<b>X / Y / Z</b>	26 (12) / - / 110 (4.33) mm (")

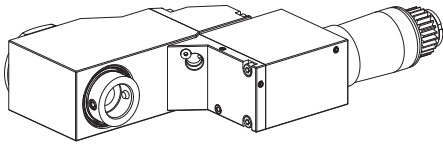

**W7145011 Milling unit**

6-10

<b>Mounting</b>	WFB 20-12
<b>Cooling</b>	external, $p_{\max}$ 40 bar
<b>Speed ratio</b>	1:1 (1)
<b>X / Y / Z</b>	26 (12) / - / 130 (5.12) mm (")

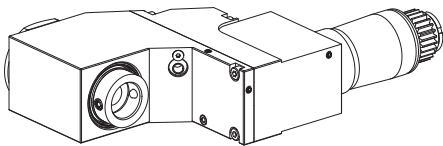

**W7145003 Milling unit**

6-11

<b>Mounting</b>	WFB 20-12
<b>Cooling</b>	external, $p_{\max}$ 40 bar
<b>Speed ratio</b>	2:1 (2)
<b>X / Y / Z</b>	26 (12) / - / 110 (4.33) mm (")

# Quick-change inserts WFB20-12 shrink-fit mounting

Catalog page

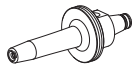

**W9990125** Quick-change inserts WFB20-12  
W-T shrink-fit chuck,  $\varnothing 3 \times 51$

7-2

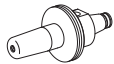

**836604** Quick-change inserts WFB20-12  
W-T shrink-fit chuck,  $\varnothing 3 \times 37$

7-3



**836614** Quick-change inserts WFB20-12  
W-T shrink-fit chuck,  $\varnothing 3 \times 17$   
2-piece type

7-4

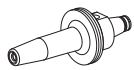

**W9990126** Quick-change inserts WFB20-12  
W-T shrink-fit chuck,  $\varnothing 4 \times 50$

7-5

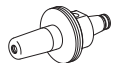

**836605** Quick-change inserts WFB20-12  
W-T shrink-fit chuck,  $\varnothing 4 \times 35$

7-6



**836615** Quick-change inserts WFB20-12  
W-T shrink-fit chuck,  $\varnothing 4 \times 17$   
2-piece type

7-7

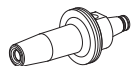

**W9990127** Quick-change inserts WFB20-12  
W-T shrink-fit chuck,  $\varnothing 6 \times 47$

7-8

# Quick-change inserts WFB20-12 shrink-fit mounting

Catalog page

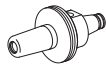

**836606**      **Quick-change inserts WFB20-12**  
W-T shrink-fit chuck,  $\varnothing 6 \times 32$

**7-9**



**836616**      **Quick-change inserts WFB20-12**  
W-T shrink-fit chuck,  $\varnothing 6 \times 17$   
2-piece type

**7-10**

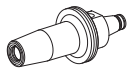

**W9990128**      **Quick-change inserts WFB20-12**  
W-T shrink-fit chuck,  $\varnothing 8 \times 45$

**7-11**

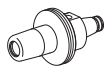

**836607**      **Quick-change inserts WFB20-12**  
W-T shrink-fit chuck,  $\varnothing 8 \times 30$

**7-12**



**836617**      **Quick-change inserts WFB20-12**  
W-T shrink-fit chuck,  $\varnothing 8 \times 20$   
2-piece type

**7-13**

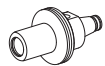

**W9990247**      **Quick-change inserts WFB20-12**  
W-T shrink-fit chuck,  $\varnothing 10 \times 27$   
2-piece type

**7-14**



# Quick-change inserts WFB20-12

## Weldon mounting

Catalog page

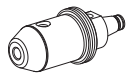

**W9990119**      **Quick-change inserts WFB20-12**  
W-T Weldon DIN 1865 form B,  $\varnothing 6 \times 43$

**7-16**

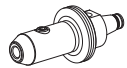

**W9990291**      **Quick-change inserts WFB20-12**  
W-T Weldon DIN 1865 form B,  $\varnothing 6 \times 43$

**7-17**

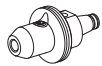

**836610**      **Quick-change inserts WFB20-12**  
W-T Weldon DIN 1865 form B,  $\varnothing 6 \times 27.5$

**7-18**



**W9990120**      **Quick-change inserts WFB20-12**  
W-T Weldon DIN 1865 form B,  $\varnothing 8 \times 43$

**7-19**



**836611**      **Quick-change inserts WFB20-12**  
W-T Weldon DIN 1865 form B,  $\varnothing 8 \times 27.5$

**7-20**



**W9990121**      **Quick-change inserts WFB20-12**  
W-T Weldon DIN 1865 form B,  $\varnothing 10 \times 43$

**7-21**

# Quick-change inserts WFB20-12 collet mounting



**W9990112**  
W-T collet, ER8

**Quick-change inserts WFB20-12**

**Catalog page**  
**7-24**



**W9990113**  
W-T collet, ER11

**Quick-change inserts WFB20-12**

**7-25**



**W9990123**  
W-T collet, ER11

**Quick-change inserts WFB20-12**

**7-26**

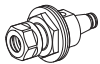

**836621**  
W-T collet, ER11

**Quick-change inserts WFB20-12**

**7-27**

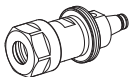

**W9990124**  
W-T collet, ER16

**Quick-change inserts WFB20-12**

**7-28**

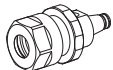

**836622**  
W-T collet, ER16

**Quick-change inserts WFB20-12**

**7-29**

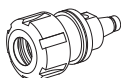

**W9990479**  
W-T collet, ER20

**Quick-Change Inserts WFB20-12**

**7-30**

## Quick-change inserts WFB20-12 collet mounting

---

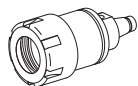

**W9990579**

**Quick-Change Inserts WFB20-12**

W-T collet, ER25

**Catalog page**

**7-31**

---

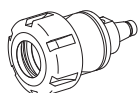

**W9990697**

**Quick-Change Inserts WFB20-12**

W-T collet, ER25

**7-32**

---

# Quick-change inserts WFB20-12 mill arbor mounting



**W9990184** Quick-change inserts WFB20-12  
W-T mill arbor,  $\varnothing 5$

Catalog page  
**7-34**

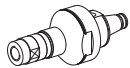

**W9990185** Quick-change inserts WFB20-12  
W-T mill arbor,  $\varnothing 8$

**7-35**

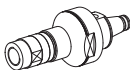

**W9990186** Quick-change inserts WFB20-12  
W-T mill arbor,  $\varnothing 10$

**7-36**



**W9990187** Quick-change inserts WFB20-12  
W-T mill arbor,  $\varnothing 13$

**7-37**



**W9990188** Quick-change inserts WFB20-12  
W-T mill arbor,  $\varnothing 16$

**7-38**

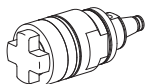

**W9990189** Quick-change inserts WFB20-12  
W-T mill arbor,  $\varnothing 22$

**7-39**

# Quick-change inserts WFB20-12 hydraulic expansion mounting

---

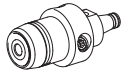

**W9990110**      **Quick-change inserts WFB20-12**  
W-T Hydro-expand, ø6

**Catalog page**  
**7-42**



**W9990111**      **Quick-change inserts WFB20-12**  
W-T Hydro-expand, ø8

**7-43**

# Quick-change inserts WFB20-12 boring tool holder

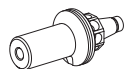

**W9990456** Quick-change inserts WFB20-12  
W-T mounting,  $\varnothing 6 \times 40$

Catalog page  
**7-46**



**W9990457** Quick-change inserts WFB20-12  
W-T mounting,  $\varnothing 8 \times 40$

**7-47**

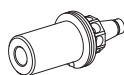

**W9990458** Quick-change inserts WFB20-12  
W-T mounting,  $\varnothing 10 \times 40$

**7-48**



**W9990211** Quick-change inserts WFB20-12  
W-T mounting,  $\varnothing 12 \times 40$

**7-49**



**W9990212** Quick-change inserts WFB20-12  
W-T mounting,  $\varnothing 16 \times 40$

**7-50**



**W9990213** Quick-change inserts WFB20-12  
W-T mounting,  $\varnothing 20 \times 40$

**7-51**

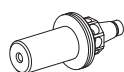

**W9990460** Quick-change inserts WFB20-12  
W-T mounting,  $\varnothing 1/8" \times 40$

**7-52**

# Quick-change inserts WFB20-12 boring tool holder

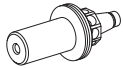

**W9990461**      **Quick-change inserts WFB20-12**  
W-T mounting,  $\varnothing 3/16"$ x40

**Catalog page**  
**7-53**

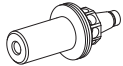

**W9990459**      **Quick-change inserts WFB20-12**  
W-T mounting,  $\varnothing 1/4"$ x40

**7-54**

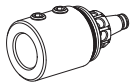

**W9990214**      **Quick-change inserts WFB20-12**  
W-T mounting,  $\varnothing 3/4"$ x40

**7-55**

# Quick-change inserts WFB20-12 Horn S-Mini

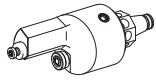

**W9990230**      **Quick-change inserts WFB20-12**  
W-T Horn clamping holder, type B114, left

**Catalog page**  
**7-58**



**W9990114**      **Quick-change inserts WFB20-12**  
W-T Horn S-mini, Type 105

**7-59**

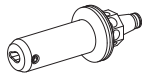

**W9990129**      **Quick-change inserts WFB20-12**  
W-T Horn S-mini, Type 105

**7-60**

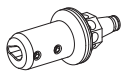

**W9990115**      **Quick-change inserts WFB20-12**  
W-T Horn S-mini, Type 110

**7-61**



# Quick-change inserts WFB20-12 turning tool holder

Catalog page  
7-64

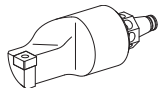

**W9990231**      **Quick-change inserts WFB20-12**  
W-T turning tool holder for CC.. 09T3..  
right-hand version

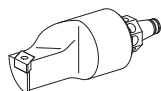

**W9990232**      **Quick-change inserts WFB20-12**  
W-T turning tool holder for DC.. 11T3..  
right-hand version

7-65

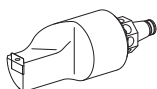

**W9990233**      **Quick-change inserts WFB20-12**  
W-T turning tool holder for VC.. 1103..  
right-hand version

7-66

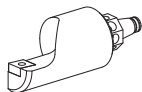

**W9990492**      **Quick-change inserts WFB20-12**  
W-T turning tool holder for CC.. 09T3..  
left-hand version

7-67

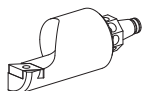

**W9990493**      **Quick-change inserts WFB20-12**  
W-T turning tool holder for DC.. 11T3..  
left-hand version

7-68



**W9990494**      **Quick-change inserts WFB20-12**  
W-T turning tool holder for VC.. 1103..  
left-hand version

7-69

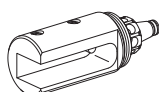

**W9990545**      **Quick-Change Inserts WFB20-12**  
square 12x12  
right exposition

7-70

# Quick-change inserts WFB20-12 tapping chuck

---



**W9990116**      **Quick-change inserts WFB20-12**  
W-T thread cutting chuck GR1

**Catalog page**  
**7-72**

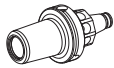

**W9990117** Quick-change inserts WFB20-12  
W-T shrink-fit position,  $\varnothing 12$

Catalog page  
**7-74**

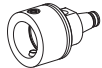

**W9990131** Quick-change inserts WFB20-12  
W-T extension 20 mm

**7-75**



**W9990288** Quick-change inserts WFB20-12  
W-T adapter for broaching tool

**7-76**



**837714** Quick-change inserts WFB20-12  
W-T blanking plugs

**7-77**

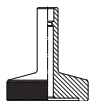

**837062** Receptacle, WFB20-12  
Shrink-fit

**7-78**

			Catalog page
	<b>W9990118</b>	<b>Adjusting Gauge, Turning Tools</b>	<b>8-2</b>
<hr/>			
	<b>900601</b>	<b>Round Shank Drawing ø12</b>	<b>8-3</b>
<hr/>			
	<b>W9990140</b>	<b>Rotary Delivery Device</b> Coolant delivery device with stationary tool holders up to 120 bar with live tool holders up to 30 bar	<b>8-4</b>
<hr/>			
	<b>W9990141</b>	<b>Rotary Delivery Device</b> Coolant delivery device with live tool holders up to 120 bar	<b>8-5</b>
<hr/>			
	<b>W9990109</b>	<b>Axial thread rolling head</b>	<b>8-6</b>
<hr/>			
	<b>W9990345</b>	<b>Axial thread rolling head</b>	<b>8-7</b>
<hr/>			
	<b>W9990341</b>	<b>Axial thread rolling head</b>	<b>8-8</b>

Catalog page  
8-9

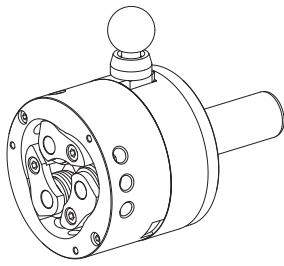

**W9990342** Axial thread rolling head

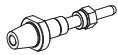

**W9990350** Receptacle arbor, ø6

8-10

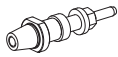

**W9990351** Receptacle arbor, ø8

8-11

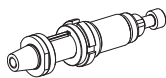

**W9990134** Receptacle arbor, ø13

8-12

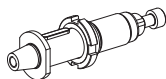

**W9990135** Receptacle arbor, ø16

8-13

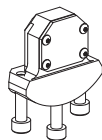



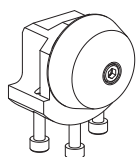

**W9990352** Counterbearing





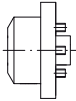
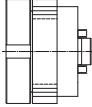

8-14



**W9990353** Counterbearing

8-15

			Catalog page
	<b>983305</b>	<b>Broaching tool, internal</b>	<b>8-16</b>
	<b>983306</b>	<b>Broaching tool, external</b>	<b>8-17</b>
	<b>326793</b>	<b>Adjusting screw</b>	<b>8-18</b>
	<b>326794</b>	<b>Adjusting screw</b>	<b>8-19</b>
	<b>326789</b>	<b>Clamping screw</b>	<b>8-20</b>
	<b>326790</b>	<b>Clamping screw</b>	<b>8-21</b>
	<b>326057</b>	<b>Set screw</b>	<b>8-22</b>

			Catalog page
	<b>326171</b>	<b>Set screw</b>	<b>8-23</b>
	<b>410156.0510</b>	<b>Set screw</b>	<b>8-24</b>
	<b>410156.0606</b>	<b>Set screw</b>	<b>8-25</b>
	<b>410156.0808</b>	<b>Set screw</b>	<b>8-26</b>
	<b>900710</b>	<b>Clamping screw</b>	<b>8-27</b>
	<b>900804</b>	<b>Clamping screw</b>	<b>8-28</b>
	<b>900812</b>	<b>Fixing pin, ø12</b>	<b>8-29</b>

Catalog page  
8-30



326795 Ball-ended thrust screw



479100.00611 Gasket V70-G1  
for receptacle WFB-20-12

8-31

835056 Tool centering device

8-32

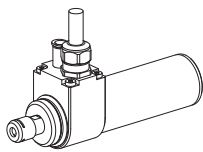

326548 Spindle drive  
Meyrat MHF-28 ER8-60

8-33

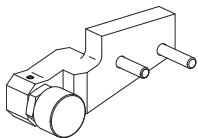

W9990516 Bar stop  
adjustable, live

8-34

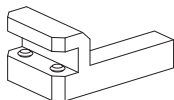

W9990546 Mounting  
Square 12x12

8-35

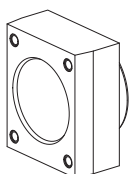

W9990515 Adapter plate

8-36



Catalog page  
8-37

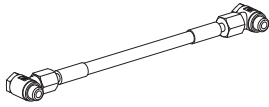

**W9990517**      Hose set

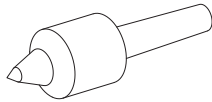

**W9990539**      Center  
MK2

8-38



**908414**      Set of jaws,  $\varnothing 1 - \varnothing 6$   
material: POM

8-39



**901539**      Set of jaws,  $\varnothing 5 - \varnothing 25$   
material: POM

8-40



**904592**      Set of jaws,  $\varnothing 5 - \varnothing 25$   
material: 16MnCr5

8-41

---

**W9800004EN Product note**

Writestar RM12/RM20

---

**W9800007EN Product note**

Hydraulic Gripper  
W7040021

---

**W9800009EN Product note**

WFB interface  
Mounting, cleaning and care, tightening torques

---

**W9800010EN Product note**

INDEX TRAUB CAPTO  
Live tools

---

**W9800011EN Product note**

INDEX TRAUB CAPTO  
Stationary tools

---

**W9800013EN Product note**

Gear cutting unit, adjustable angle  
Face contact cupped

---

**W9800015EN Product note**

External cooling lubricant supply  
Internal cooling lubricant supply with internal transfer, set screw  
Normal pressure up to 80 bar, High pressure above 80 bar  
Pressure distribution

---

## **W9800024EN Product note**

External cooling lubricant supply

Internal cooling lubricant supply with internal transfer, blanking plug

Normal pressure up to 80 bar, High pressure above 80 bar

---

## **W9800023EN Product note**

External cooling lubricant supply

Internal cooling lubricant supply with external transfer

Normal pressure up to 80 bar, High pressure above 80 bar

---



**Tool Holder Fix**

**Turret Head**

**TRAUB TNL 18P**

**TRAUB TNL 18-7**

**TRAUB TNL 18-7B**

**TRAUB TNL 18-9**

## Drilling tool holder

<b>Shank</b>	Compact shank 45
<b>Mounting</b>	ER 16
<b>Cooling</b>	external and internal, $p_{\max}$ 80 bar
<b>X / Y / Z</b>	20 (0.79) / - / - mm (")

### Matching accessories

Clamping collet	901930.1---
tapping tool collet	3230--
Clamping collet	W99903--
tapping tool collet	WZ9990.9506F
Collet chuck	W9990065-
Clamping collet, sealed	W999085-
Clamping nut*	901939.5161
Clamping nut	326691
Bush*	W67530.0824
Nozzle*	W67500.3208
Hollow screw*	W67530.0818
Nozzle	W00019.0216
Tube*	W9990559
Spanner	490219.3161

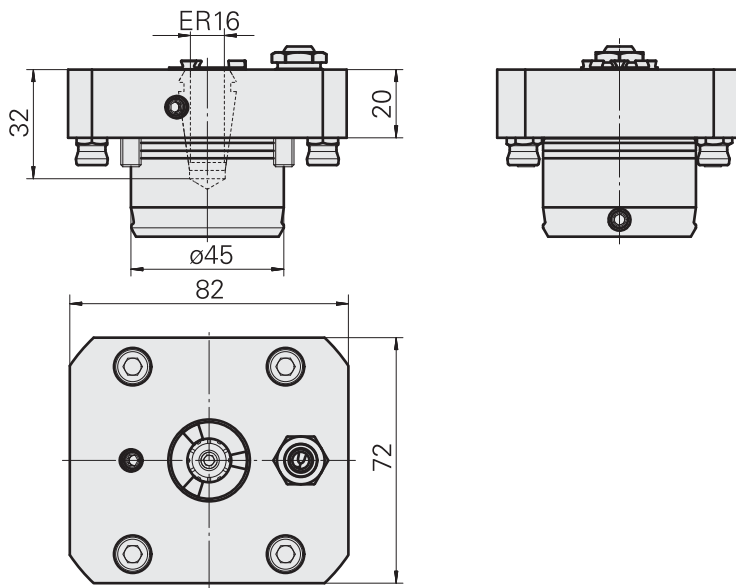

 Specifically for turrets on  
TRAUB TNL 18-7(B).

\* This article is included

## Drilling tool holder

<b>Shank</b>	Compact shank 45
<b>Mounting</b>	ER 25
<b>Cooling</b>	external and internal, $p_{\max}$ 80 bar
<b>X / Y / Z</b>	30 (1.18) / - / - mm (")

### Matching accessories

Clamping collet	901930.3---
tapping tool collet	3224--
Collet chuck	W999067-
tapping tool collet	WZ9990.9507F
Clamping collet, sealed	W999085-
Clamping nut*	901939.5251
Sealing washer	W99904--
Bush*	W67530.0824
Nozzle*	W67500.3208
Hollow screw	W67530.0818
Nozzle	W00019.0216
Tube*	W9990559
Spanner	490219.3251

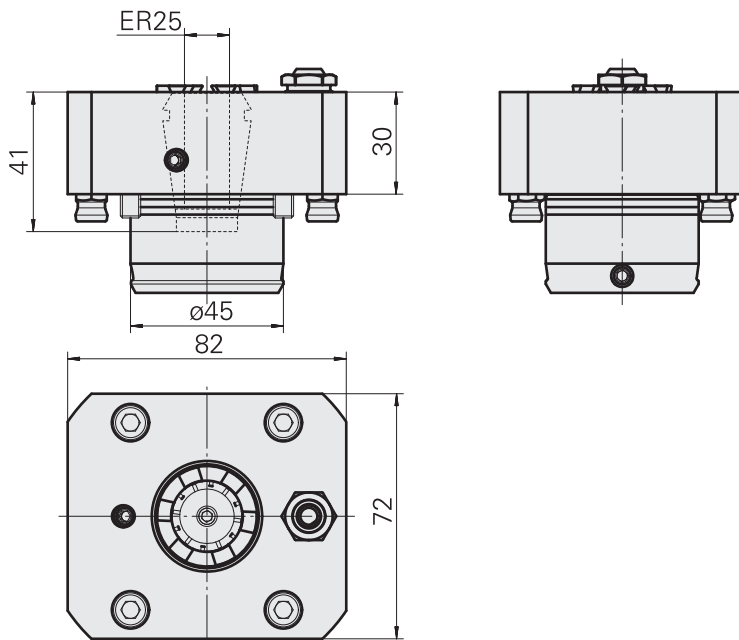

 Specifically for turrets on  
TRAUB TNL 18-7(B).

\* This article is included

## Drilling tool holder

<b>Shank</b>	Compact shank 45
<b>Mounting</b>	WFB 20-12
<b>Cooling</b>	external and internal, $p_{\max}$ 80 bar
<b>X / Y / Z</b>	20 (0.79) / - / - mm (")

### Matching accessories

<b>Bush*</b>	W67530.0824
<b>Nozzle*</b>	W67500.3208
<b>Hollow screw*</b>	W67530.0818
<b>Nozzle</b>	W00019.0216
<b>Tube*</b>	W9990559
<b>WFB with shrink-fit mounting</b>	904006
<b>WFB with Weldon mounting</b>	904007
<b>WFB with collet mounting</b>	904008
<b>WFB hydr. expansion mounting</b>	904010
<b>WFB for tap chuck</b>	WZ9990.9613F
<b>WFB miscellaneous mountings</b>	WZ9990.9612F
<b>Grub screw*</b>	326171

### Other documents

<b>Product note</b>	<a href="#">W980009en</a>
---------------------	---------------------------

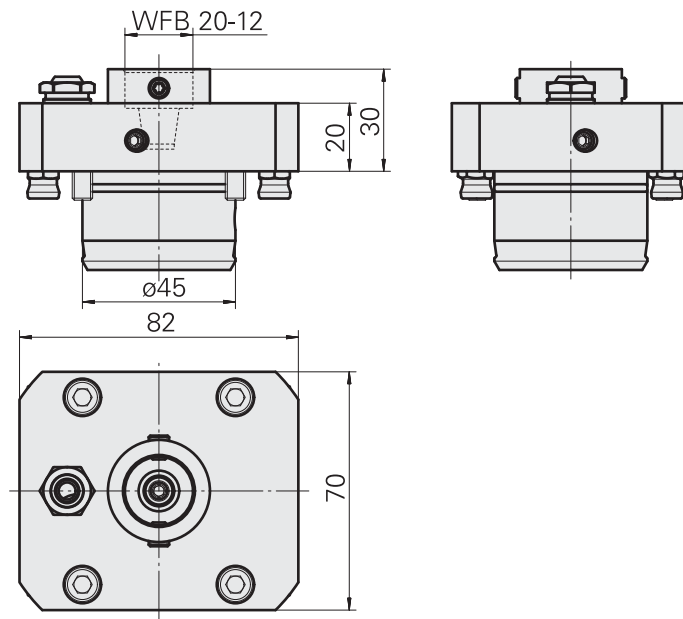

 Specifically for turrets on TRAUB TNL 18-7(B).

\* This article is included





## Turning tool holder, triple

<b>Shank</b>	Compact shank 45
<b>Mounting</b>	Square 12x12
<b>Cooling</b>	external, $p_{\max}$ 10 bar
<b>X / Y / Z</b>	85 (3.35) / $\pm 13^\circ$ / -10 (-0.39) mm (")

### Matching accessories

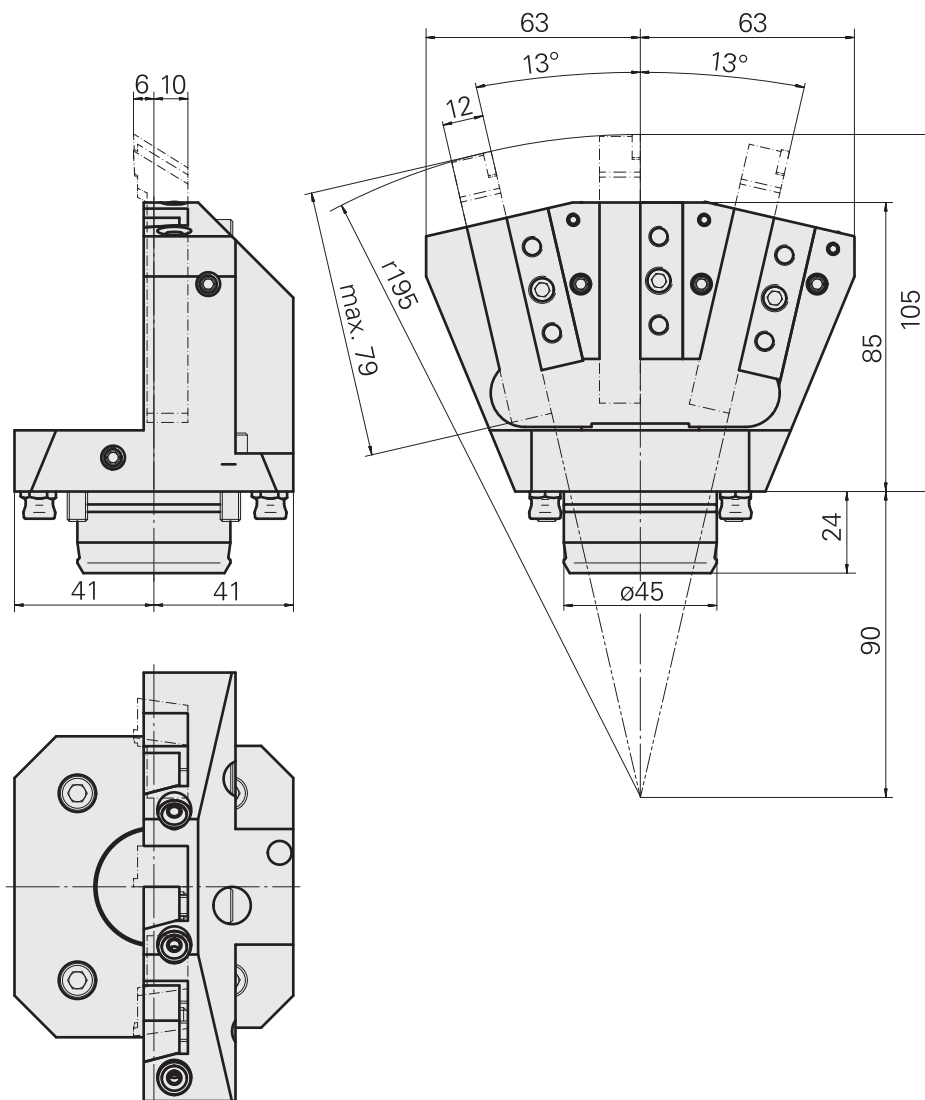
<b>Nozzle*</b>	474550.0081
----------------	-------------



 Particularly suitable for the application on the circular axis.

\* This article is included

## Turning tool holder

<b>Shank</b>	Compact shank 45
<b>Mounting</b>	square 16x16
<b>Cooling</b>	external, $p_{\max}$ 80 bar
<b>X / Y / Z</b>	79 (3.11) / - / -14 (-0.55) mm (")

### Matching accessories

<b>Mount</b>	W9990546
<b>Nozzle*</b>	W67500.3208
<b>Bush*</b>	W67530.0824
<b>Hollow screw*</b>	W67530.0818
<b>Tube</b>	W9990559
<b>Nozzle</b>	W00019.0216

### Other documents

<b>Product note</b>	<a href="#">W9800004en</a>
---------------------	----------------------------

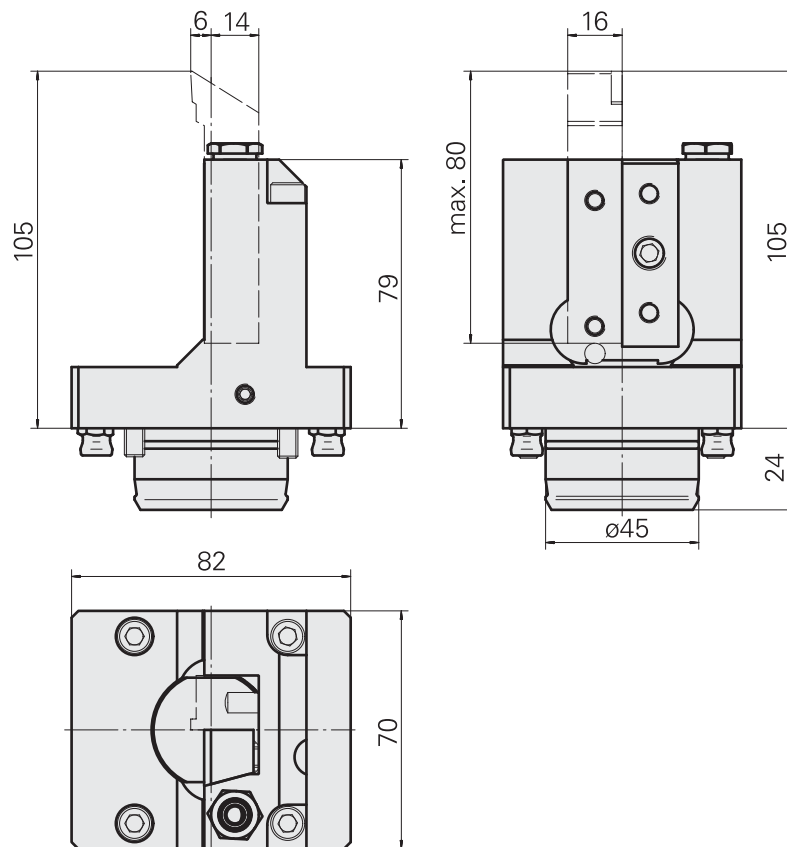

\* This article is included

## Turning tool holder, double

<b>Shank</b>	Compact shank 45
<b>Mounting</b>	square 16x16
<b>Cooling</b>	external, $p_{\max}$ 80 bar
<b>X / Y / Z</b>	84 (3.31) / $\pm 10^\circ$ / -14 (-0.55) mm (")

### Matching accessories

<b>Nozzle*</b>	W67500.3208
<b>Bush*</b>	W67530.0824
<b>Tube*</b>	904876
<b>Nozzle*</b>	W67500.3208
<b>Hollow screw*</b>	W67530.0818
<b>Nozzle</b>	W00019.0216
<b>Tube*</b>	W9990559

### Other documents

<b>Product note</b>	W980004en
---------------------	-----------

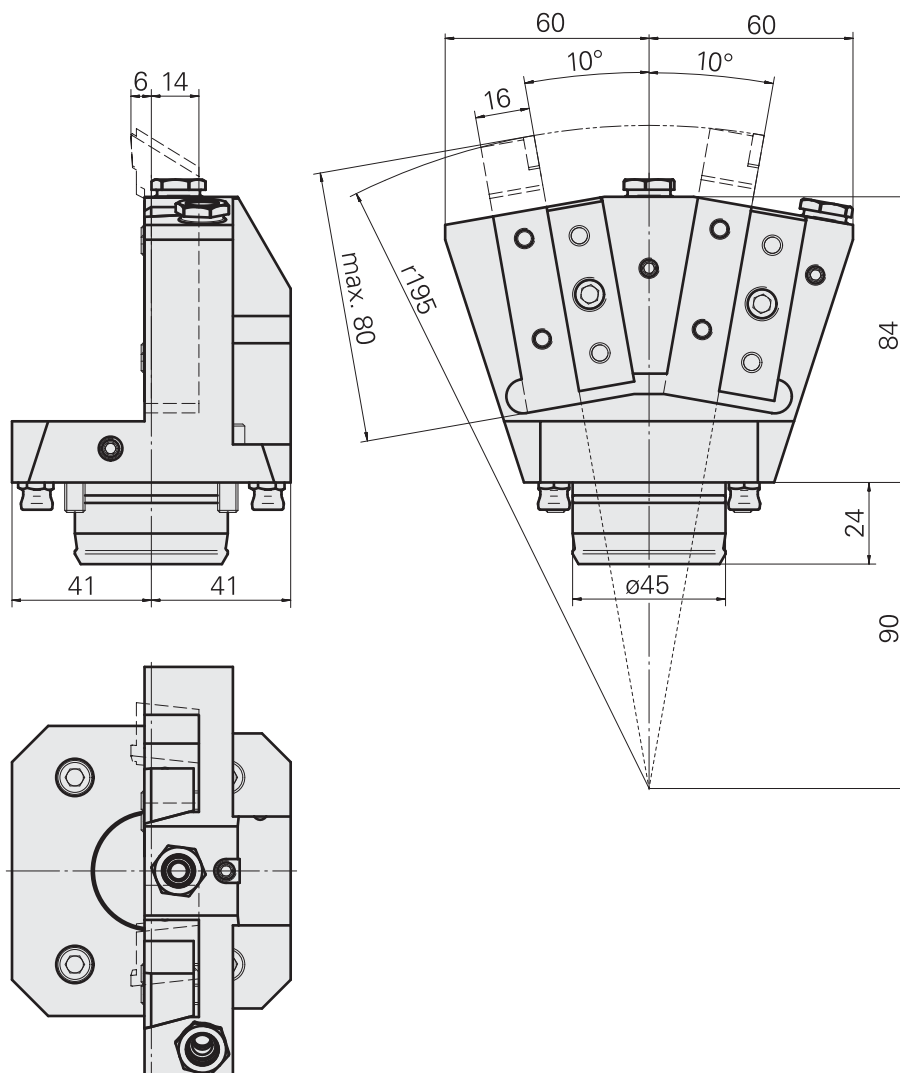

 Particularly suitable for the application on the circular axis.

\* This article is included

## Turning tool holder, left-handed run

<b>Shank</b>	Compact shank 45
<b>Mounting</b>	square 16x16
<b>Cooling</b>	external, $p_{max}$ 80 bar
<b>X / Y / Z</b>	79 (3.11) / - / -14 (-0.55) mm (")

### Matching accessories

<b>Nozzle*</b>	W67500.3208
<b>Bush*</b>	W67530.0824
<b>Tube*</b>	W9990559
<b>Hollow screw*</b>	W67530.0818
<b>Nozzle</b>	W00019.0216

### Other documents

<b>Product note</b>	W9800004en
---------------------	------------

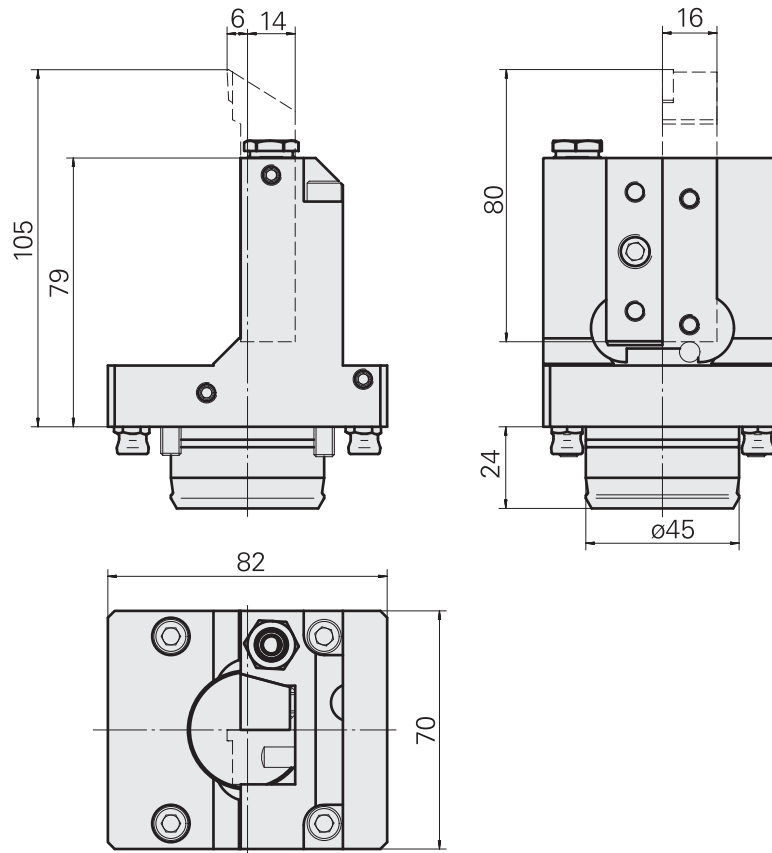

 Only for left-handed run.

\* This article is included

## Turning tool holder

<b>Shank</b>	Compact shank 45
<b>Mounting</b>	square 20x20
<b>Cooling</b>	external, $p_{max}$ 80 bar
<b>X / Y / Z</b>	85 (3.35) / - / -19 (-0.75) mm (")

### Matching accessories

<b>Nozzle*</b>	W67500.3208
<b>Bush*</b>	W67530.0824
<b>Hollow screw*</b>	W67530.0818
<b>Tube*</b>	W9990559
<b>Nozzle</b>	W00019.0216

### Other documents

<b>Product note</b>	<a href="#">W980004en</a>
---------------------	---------------------------

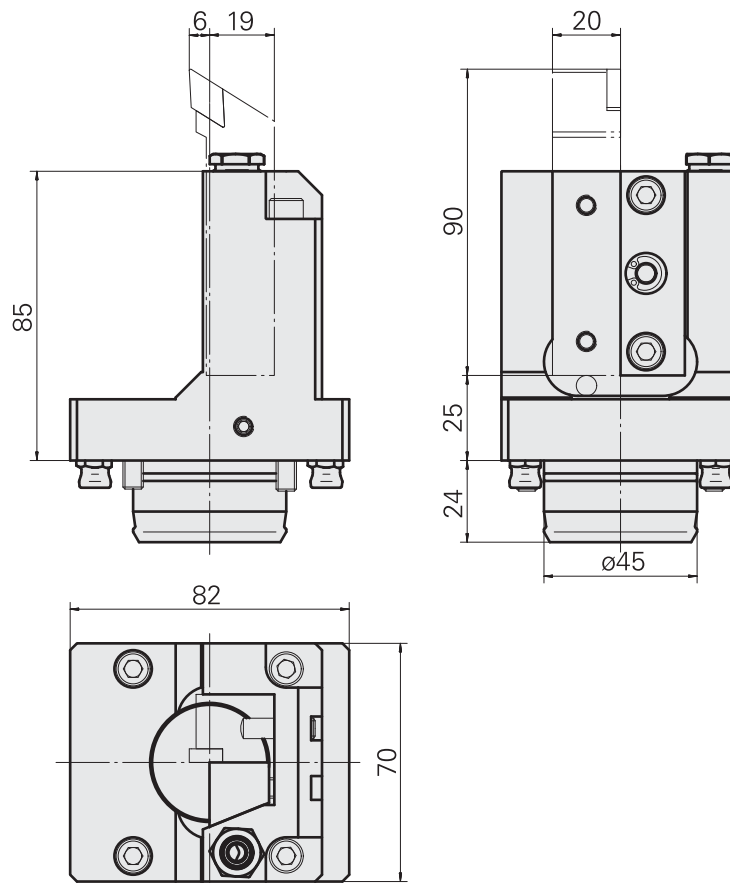

\* This article is included

## Grooving tool holder

<b>Shank</b>	Compact shank 45
<b>Mounting</b>	Trapezoid 26x8
<b>Cooling</b>	external, $p_{\max}$ 80 bar
<b>X / Y / Z</b>	68 (2.68) / - / -6 (-0.24) mm (")

### Matching accessories

<b>Bush*</b>	W02010.0002
<b>Nozzle*</b>	904837
<b>Hollow screw*</b>	W02013.0001
<b>Bar stop</b>	W9990516

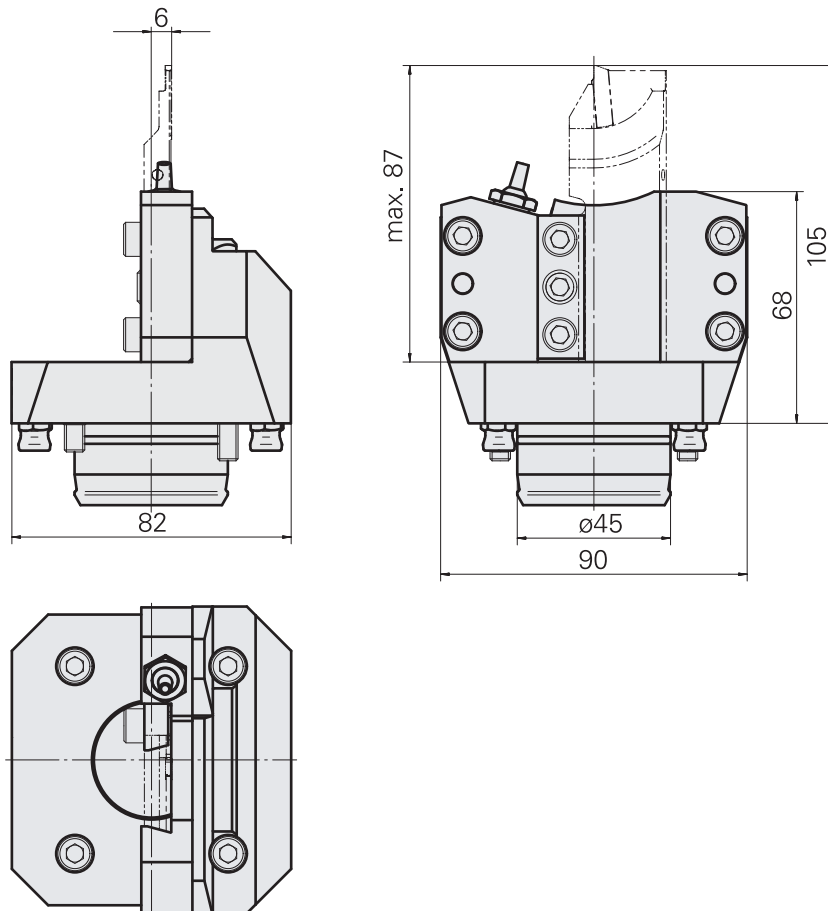

\* This article is included

## Grooving tool holder

<b>Shank</b>	Compact shank 45
<b>Mounting</b>	Trapezoid 26x8
<b>Cooling</b>	external and internal, $p_{\max}$ 80 bar
<b>X / Y / Z</b>	68 (2.68) / - / 6 (0.24) mm (")

### Matching accessories

<b>Bush*</b>	W02010.0002
<b>Hollow screw*</b>	W02013.0001
<b>Nozzle*</b>	904837
<b>Locking screw*</b>	910677
<b>Gasket ring*</b>	316038

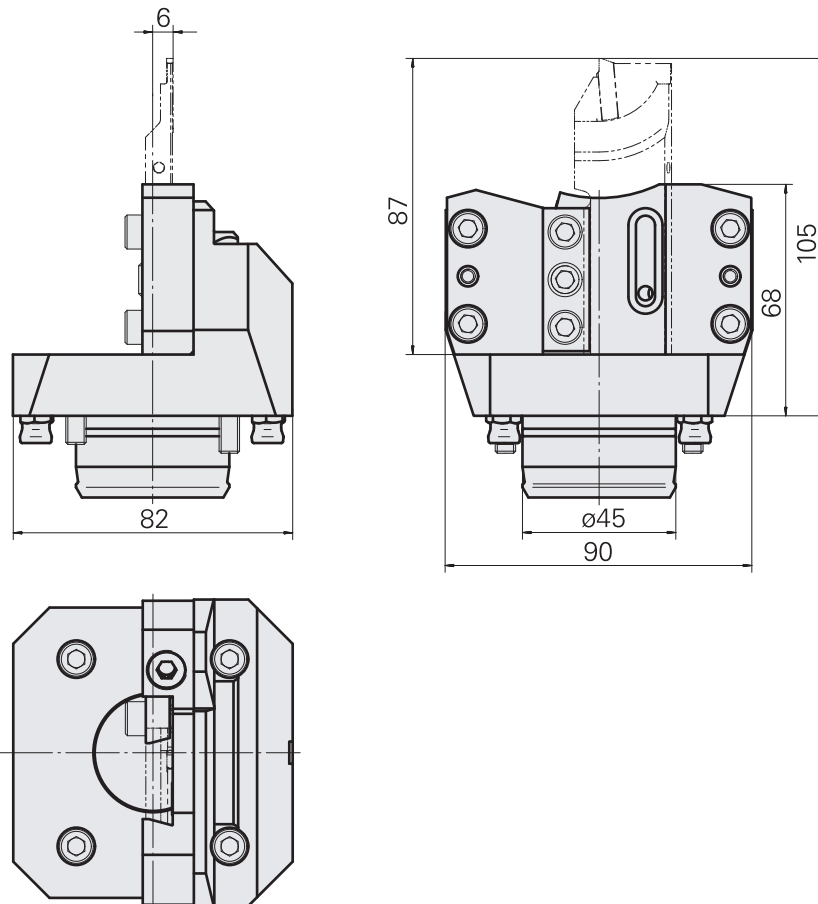

\* This article is included

## Grooving tool holder

<b>Shank</b>	Compact shank 45
<b>Mounting</b>	Trapezoid 32x8
<b>Cooling</b>	external, $p_{\max}$ 80 bar
<b>X / Y / Z</b>	68 (2.68) / - / -6 (-0.24) mm (")

### Matching accessories

<b>Hollow screw*</b>	W02013.0001
<b>Nozzle*</b>	904837
<b>Bush*</b>	W02010.0002
<b>Bar stop</b>	W9990516

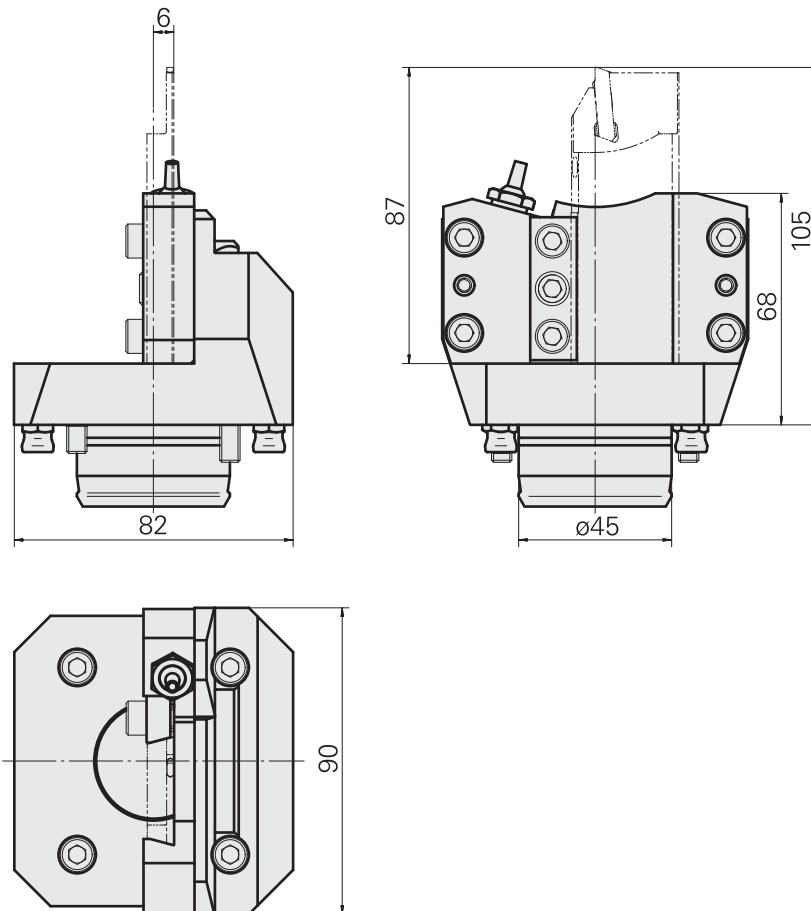

\* This article is included



## Grooving tool holder

<b>Shank</b>	Compact shank 45
<b>Mounting</b>	Trapezoid 32x8
<b>Cooling</b>	external and internal, $p_{\max}$ 80 bar
<b>X / Y / Z</b>	68 (2.68) / - / 6 (0.24) mm (")

### Matching accessories

<b>Bush*</b>	W02010.0002
<b>Hollow screw*</b>	W02013.0001
<b>Nozzle*</b>	904837
<b>Locking screw*</b>	910677
<b>Gasket ring*</b>	316038

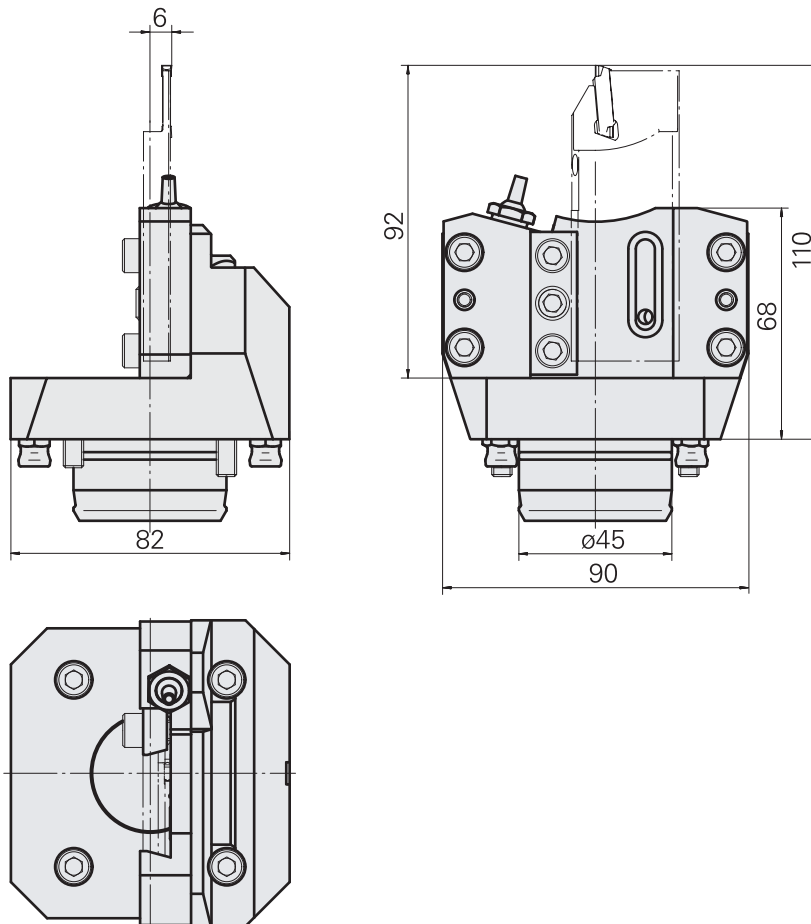

\* This article is included

**Basic holder, triple**

<b>Shank</b>	Compact shank 45
<b>Mounting</b>	D24
<b>Cooling</b>	external and internal, $p_{\max}$ 80 bar
<b>X / Y / Z</b>	52 (25) / $\pm 13^\circ$ / 0 mm (")

**Matching modules**

<b>Mount</b>	W9990703
<b>Mount</b>	W9990704

**Matching accessories**

<b>Nozzle*</b>	W67500.3208
<b>Hollow screw*</b>	W67530.0818
<b>Bush*</b>	W67530.0824
<b>Nozzle</b>	W00019.0216
<b>Tube*</b>	W9990559

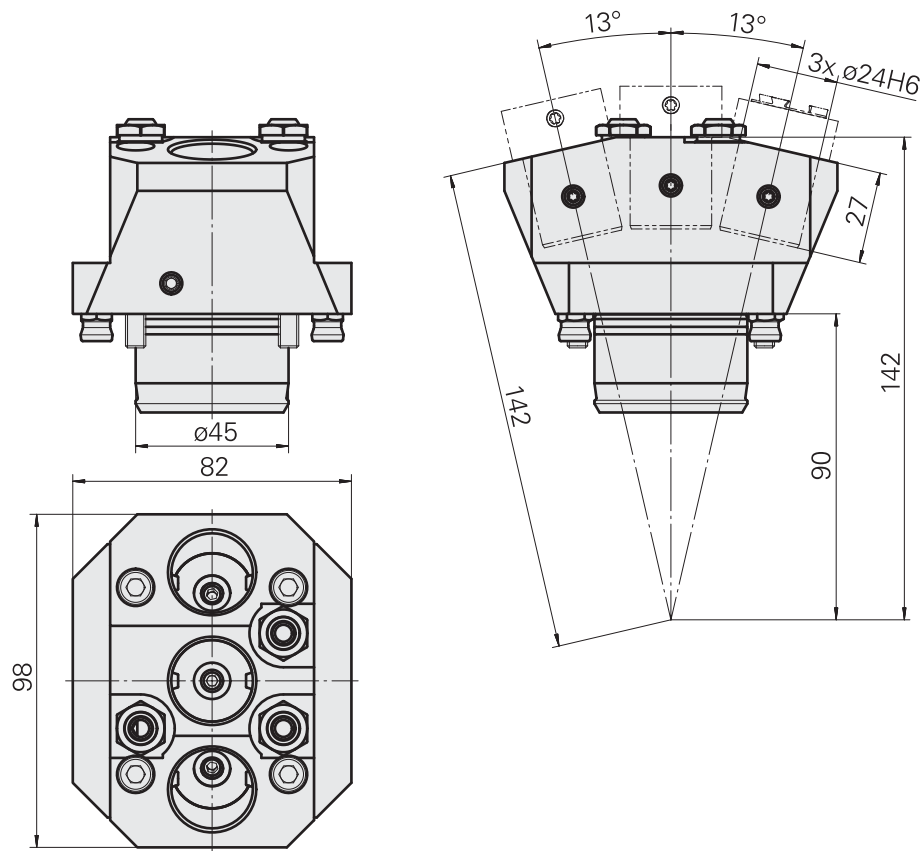

 Specifically for turrets on TRAUB TNL 18-7(B).

\* This article is included

**Mount**

<b>Shank</b>	–
<b>Mounting</b>	ER 16
<b>Cooling</b>	internal, p <sub>max</sub> 80 bar
<b>X / Y / Z</b>	12 (0.47) / – / – mm (")

**Matching base holder**

Basic holder	W7040057
--------------	----------

**Matching accessories**

Clamping collet	W99903--
Clamping collet	901930.1--
tapping tool collet	WZ9990.9506F
tapping tool collet	3230--
Collet chuck	W999065-
Clamping collet, sealed	W999083-
Clamping nut	901939.5161
Spanner	490219.3161

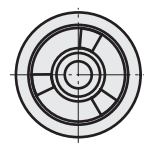
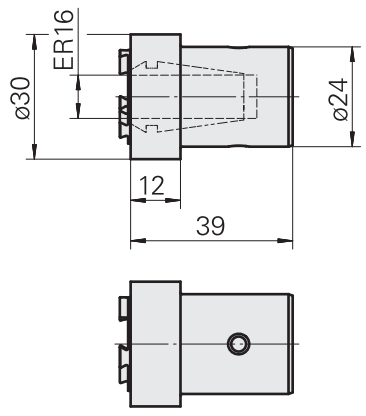

## Mount

<b>Shank</b>	–
<b>Mounting</b>	WFB 20-12
<b>Cooling</b>	internal, $p_{max}$ 80 bar
<b>X / Y / Z</b>	15 (0.59) / – / – mm (")

### Matching base holder

Basic holder	W7040057
--------------	----------

### Matching accessories

WFB with shrink-fit mounting	904006
WFB with Weldon mounting	904007
WFB with collet mounting	904008
WFB with mill arbor mounting	904009
WFB hydr. expansion mounting	904010
WFB for Turning tool holder	904011
WFB for tap chuck	WZ9990.9613F
WFB miscellaneous mountings	WZ9990.9612F
Grub screw*	326171

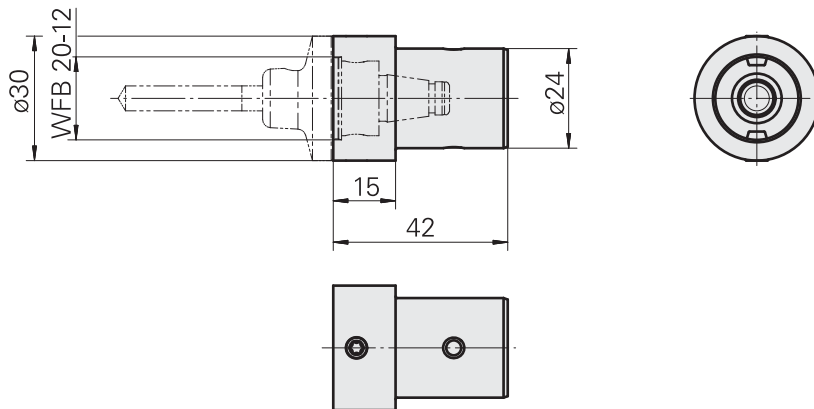

### Other documents

Product note	W9800009en
--------------	------------

\* This article is included

## Basic holder

<b>Shank</b>	Compact shank 45
<b>Mounting</b>	INDEX TRAUB CAPTO C3
<b>Cooling</b>	internal, $p_{\max}$ 80 bar
<b>X / Y / Z</b>	57 (2.24) / – / 16 (0.63) mm (")

### Matching accessories

Quick-Change Insert	WZ9990.3000F
---------------------	--------------

### Other documents

Product note	<a href="#">W9800011en</a>
--------------	----------------------------

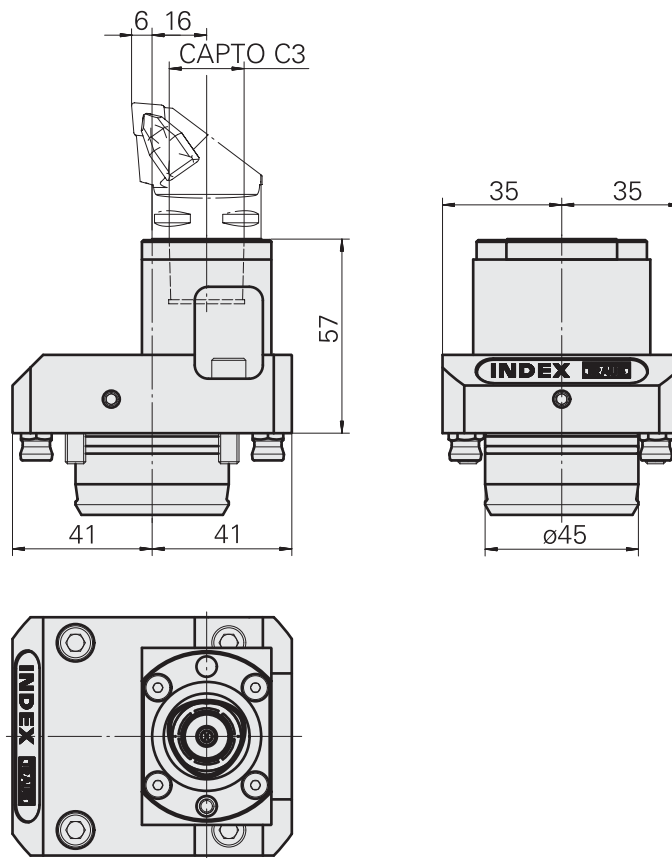



## Basic holder, triple

<b>Shank</b>	Compact shank 45
<b>Mounting</b>	D20
<b>Cooling</b>	external, internal optional, $p_{max}$ 80 bar
<b>reversible 180°</b>	no
<b>X / Y / Z</b>	85 (3.35) / $\pm 12.5^\circ$ / 16 (0.63) mm (")

<b>Matching modules</b>	
<b>Mount</b>	W9990107
<b>Mount</b>	W9990344

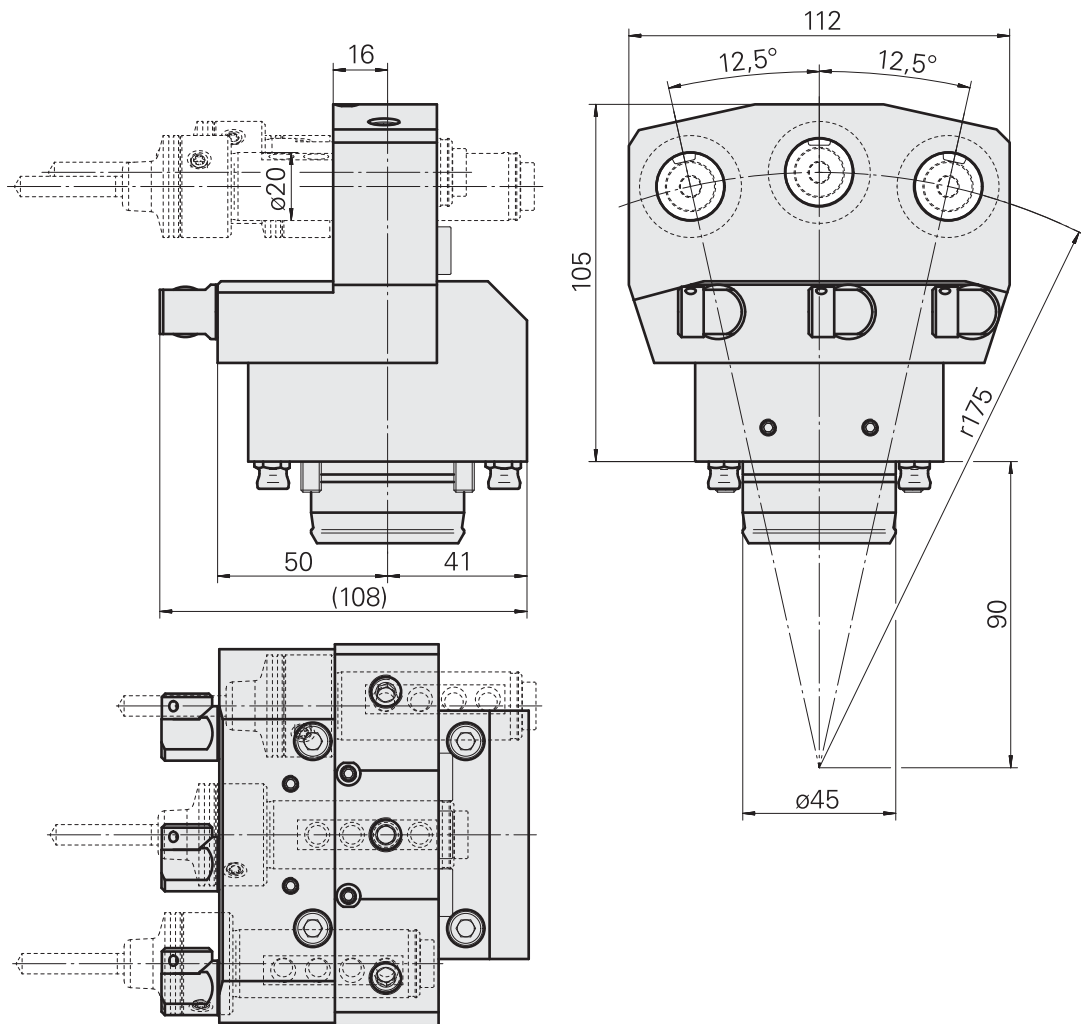
<b>Matching accessories</b>	
<b>Hose set</b>	W9990517
<b>Bush</b>	471112.06
<b>Conical ring</b>	471060.0601
<b>Tube</b>	W9990658
<b>Grub screw*</b>	326057



 Not suitable for machining on the main spindle of the TRAUB TNL18 and TNL32.

\* This article is included

## Basic holder, triple

<b>Shank</b>	Compact shank 45
<b>Mounting</b>	D20
<b>Cooling</b>	external, internal optional, $p_{max}$ 80 bar, internal 160 bar optional
<b>reversible 180°</b>	no
<b>X / Y / Z</b>	85 (3.35) / $\pm 12.5^\circ$ / -82 (-3.23) mm (")

### Matching modules

<b>Mount</b>	W9990107
<b>Mount</b>	W9990344

### Matching accessories

<b>Hose set</b>	W9990517
<b>Grub screw*</b>	326057

### Other documents

<b>Product note</b>	W9800023en
---------------------	------------

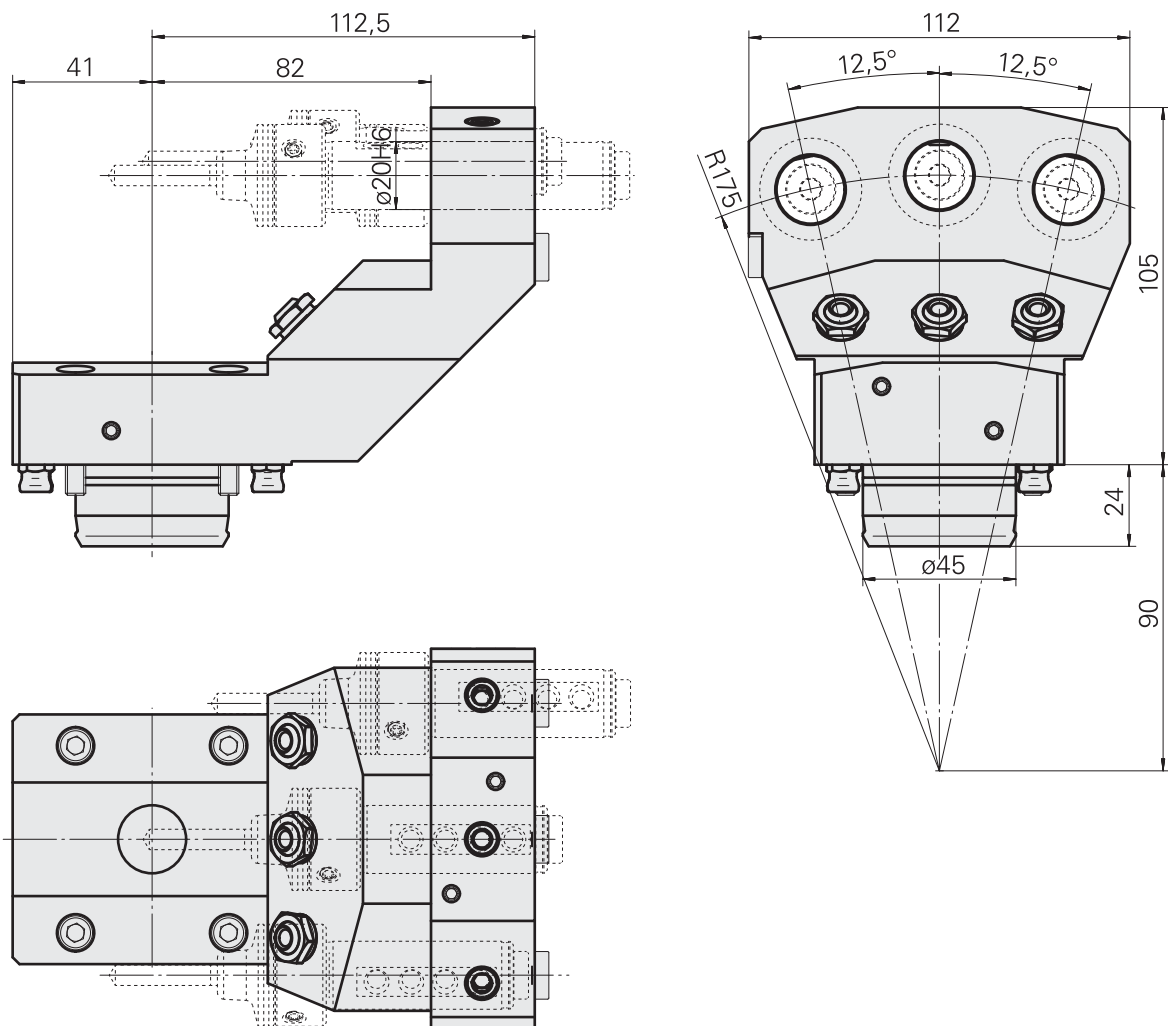

**i** Internal coolant supply with 160 bar is possible only on stations with an additional fluid-transfer station.

\* This article is included

## Mount

<b>Shank</b>	–
<b>Mounting</b>	ER 16
<b>Cooling</b>	internal, $p_{\max}$ 80 bar
<b>X / Y / Z</b>	– / – / – mm (")

## Matching base holder

<b>Drilling tool holder</b>	W1250066
<b>Basic holder</b>	W7040014
<b>Basic holder</b>	W7040028
<b>Basic holder</b>	W7040033
<b>Basic holder</b>	W7040067
<b>Basic holder</b>	W7040069
<b>Basic holder</b>	W7040019

## Matching accessories

<b>Clamping collet</b>	W99903--
<b>Clamping collet</b>	901930.1---
<b>tapping tool collet</b>	WZ9990.9506F
<b>tapping tool collet</b>	3230--
<b>Collet chuck</b>	W999065-
<b>Clamping collet, sealed</b>	W999083-
<b>Clamping nut*</b>	901939.6161
<b>Clamping nut</b>	W9990347
<b>Sealing washer</b>	W999036-
<b>Hose set</b>	W9990517
<b>Spanner</b>	490219.2161

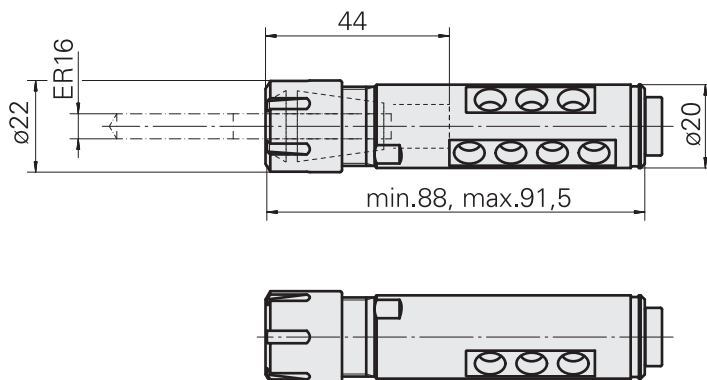

\* This article is included



## Mount

<b>Shank</b>	–
<b>Mounting</b>	WFB 20-12
<b>Cooling</b>	internal, $p_{\max}$ 80 bar
<b>X / Y / Z</b>	– / – / – mm (")

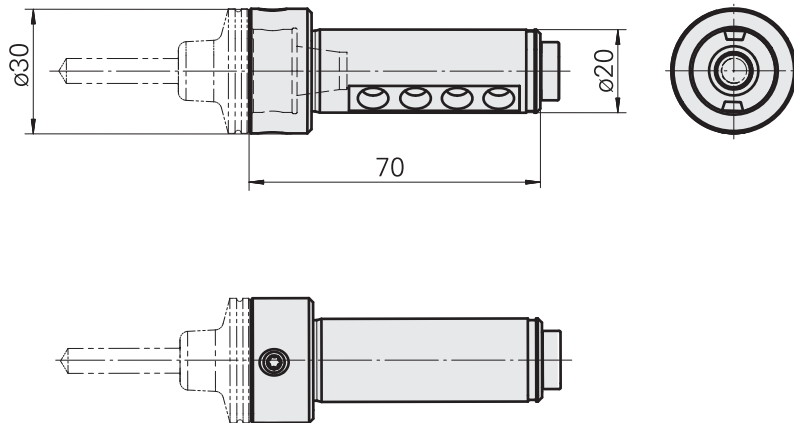

### Matching base holder

Basic holder	W7040014
Basic holder	W7040019
Basic holder	W7040069
Basic holder	W7040033
Basic holder	W7040067
Basic holder	W7040028

### Matching accessories

Hose set	W9990517
Grub screw*	326171
WFB with shrink-fit mounting	904006
WFB with Weldon mounting	904007
WFB with collet mounting	904008
WFB with mill arbor mounting	904009
WFB hydr. expansion mounting	904010
WFB for Turning tool holder	904011
WFB for Horn S-Mini	904012
WFB for turning tool holder	904013
WFB for tap chuck	WZ9990.9613F
WFB miscellaneous mountings	WZ9990.9612F

### Other documents

Product note	<a href="#">W9800009en</a>
--------------	----------------------------

\* This article is included

## Basic holder

<b>Shank</b>	Compact shank 45
<b>Mounting</b>	D24
<b>Cooling</b>	external and internal, $p_{max}$ 80 bar
<b>X / Y / Z</b>	85 (3.35) / - / 16 (0.63) mm (")

### Matching modules

<b>Mount</b>	W9990105
<b>Mount</b>	W9990106
<b>Mount</b>	W9990346
<b>Mount</b>	W9990506
<b>Mount</b>	W9990530
<b>Mount</b>	W9990541

### Matching accessories

<b>Conical ring*</b>	314739
<b>Cap screw*</b>	314740
<b>Tube*</b>	W9990658

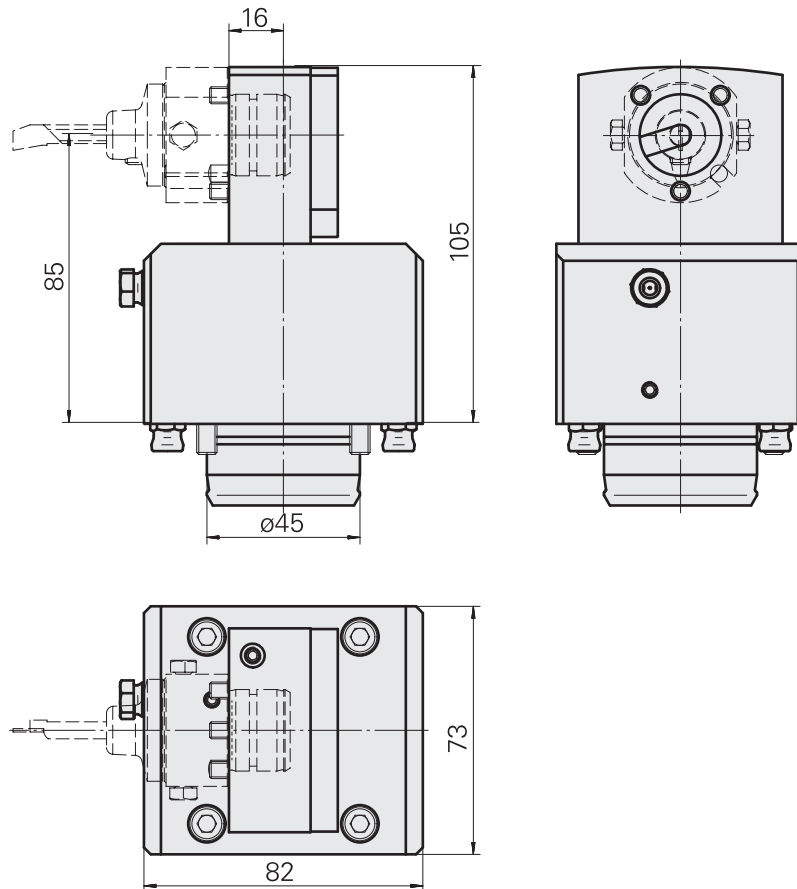

 Not suitable for machining on the main spindle of the TRAUB TNL18 and TNL32.

\* This article is included

## Basic holder

<b>Shank</b>	Compact shank 45
<b>Mounting</b>	D24
<b>Cooling</b>	external and internal, $p_{\max}$ 80 bar
<b>reversible 180°</b>	no
<b>X / Y / Z</b>	85 (3.35) / - / -71 (-2.8) mm (")

### Matching modules

<b>Mount</b>	W9990105
<b>Mount</b>	W9990106
<b>Mount</b>	W9990346
<b>Mount</b>	W9990506
<b>Mount</b>	W9990530
<b>Mount</b>	W9990541
<b>Mount</b>	W9990562
<b>Mount</b>	W9990575
<b>Mount</b>	W9990577

### Matching accessories

<b>Bush*</b>	W67530.0824
<b>Hollow screw*</b>	W67530.0818
<b>Nozzle*</b>	W67500.3208
<b>Tube*</b>	W9990559

### Other documents

<b>Product note</b>	<a href="#">W9800024en</a>
---------------------	----------------------------

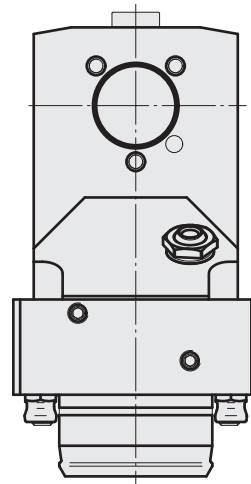
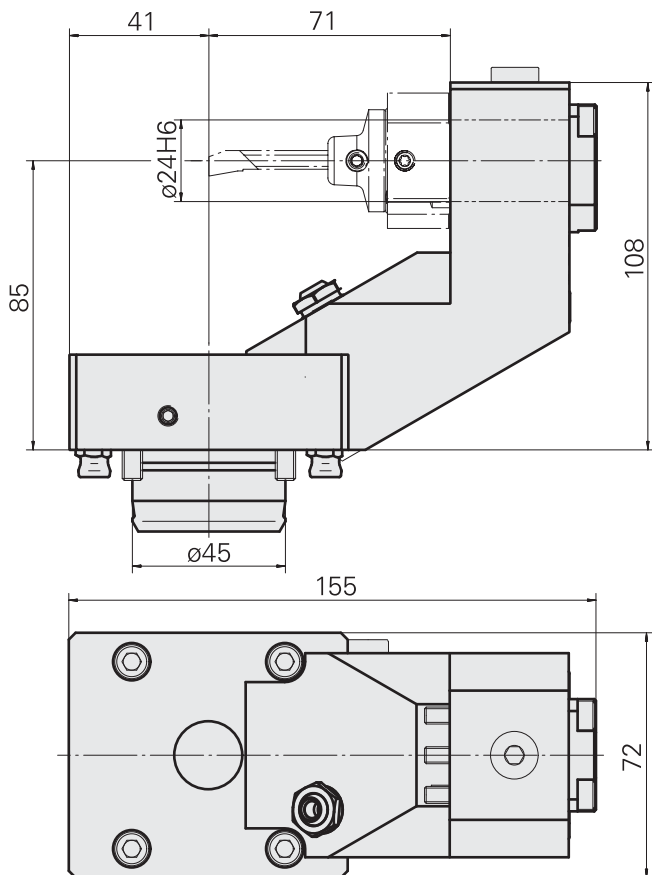

\* This article is included

## Mount

<b>Shank</b>	–
<b>Mounting</b>	ER 16
<b>Cooling</b>	internal, $p_{max}$ 80 bar
<b>X / Y / Z</b>	54 (2.13) / – / – mm (")

### Matching base holder

Basic holder	W7040004
Basic holder	W7040015
Basic holder	W7040040
Basic holder	W7040088
Basic holder	W7040086
Basic holder	W7040087
Basic holder	W7040062

### Matching accessories

Clamping collet	901930.1--
Clamping collet	W99903--
tapping tool collet	WZ9990.9506F
tapping tool collet	3230--
Collet chuck	W999065-
Clamping collet, sealed	W999083-
Clamping nut*	901939.6161
Clamping nut	W9990347
Sealing washer	W999036-
Spanner	490219.2161

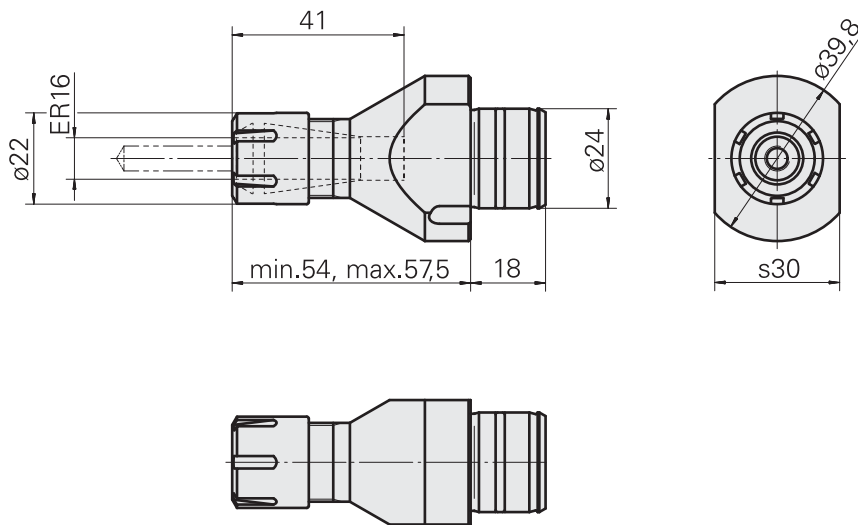

\* This article is included

## Mount

<b>Shank</b>	—
<b>Mounting</b>	ER 20
<b>Cooling</b>	internal, $p_{max}$ 80 bar
<b>X / Y / Z</b>	54 (2.13) / — / — mm (")

### Matching base holder

Basic holder	W7040004
Basic holder	W7040015
Basic holder	W7040088
Basic holder	W7040086
Basic holder	W7040087
Basic holder	W7040062

### Matching accessories

Clamping collet	901930.2--
tapping tool collet	3234--
Collet chuck	W999066-
Clamping collet, sealed	W999084-
Clamping nut*	901939.0201
Spanner	490219.0201

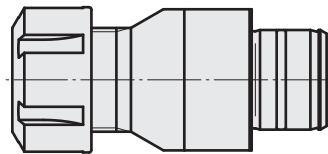
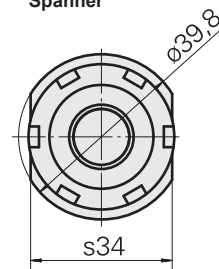
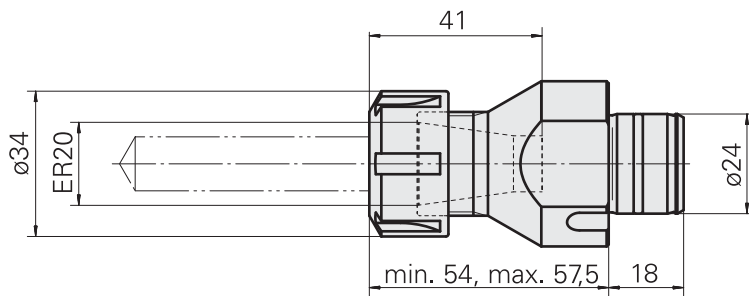

\* This article is included

## Mount

<b>Shank</b>	–
<b>Mounting</b>	ER 25
<b>Cooling</b>	internal, $p_{max}$ 80 bar
<b>X / Y / Z</b>	47 (1.85) / – / – mm (")

### Matching base holder

Basic holder	W7040086
Basic holder	W7040088
Basic holder	W7040062
Basic holder	W7040087
Basic holder	W7040004

### Matching accessories

Clamping collet	901930.3---
tapping tool collet	3224--
tapping tool collet	WZ9990.9507F
Collet chuck	W999067-
Clamping collet, sealed	W999085-
Clamping nut*	901939.0251
Spanner	490219.0251

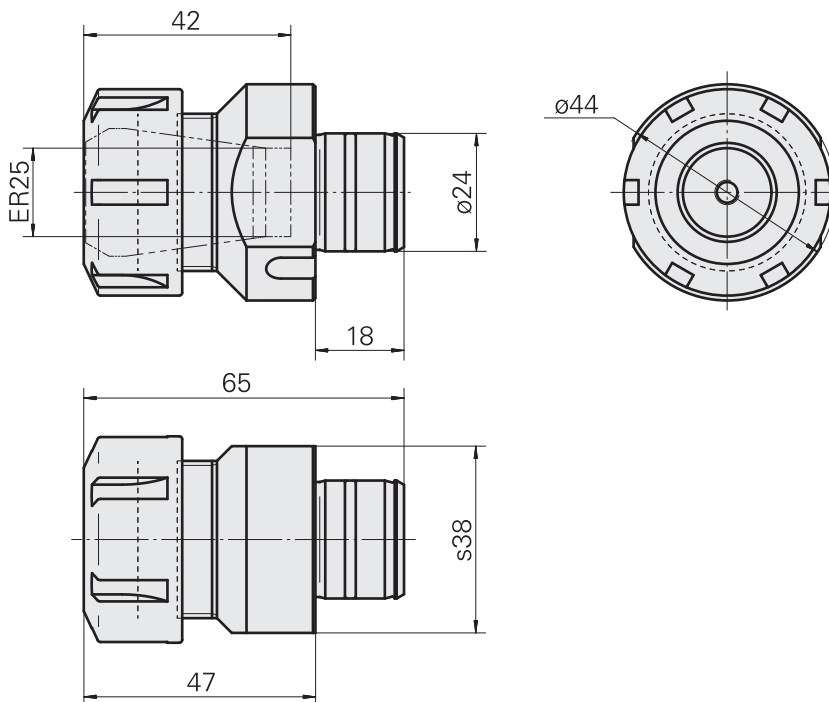

\* This article is included

## Mount

<b>Shank</b>	–
<b>Mounting</b>	ER 25
<b>Cooling</b>	internal, $p_{\max}$ 80 bar
<b>X / Y / Z</b>	– / – / – mm (")

### Matching base holder

Basic holder	W7040062
Basic holder	W7040088
Basic holder	W7040086
Basic holder	W7040087

### Matching accessories

Clamping collet	901930.3--
tapping tool collet	3230--
tapping tool collet	WZ9990.9507F
Collet chuck	W999067-
Clamping collet, sealed	W999085-
Clamping nut*	901939.0251
Spanner	490219.0251

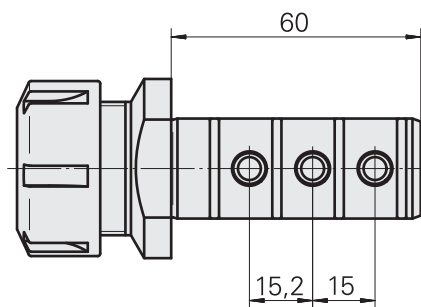
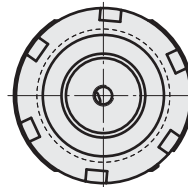
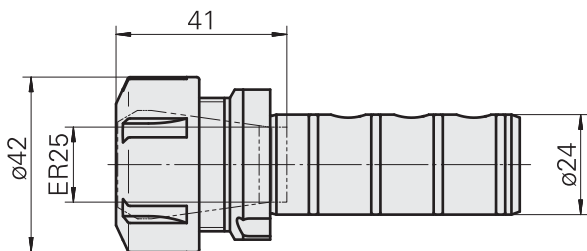

\* This article is included

## Mount

<b>Shank</b>	–
<b>Mounting</b>	D12
<b>Cooling</b>	internal, $p_{\max}$ 80 bar
<b>X / Y / Z</b>	36 (1.42) / – / – mm (")

## Matching base holder

Basic holder	W7040005
Basic holder	W7040015
Basic holder	W7040088
Basic holder	W7040062
Basic holder	W7040086
Basic holder	W7040087
Basic holder	W7040004
Basic holder	W7040040

## Matching accessories

Bush	W94280.21--
Clamping screw*	900804
Clamping screw*	900710

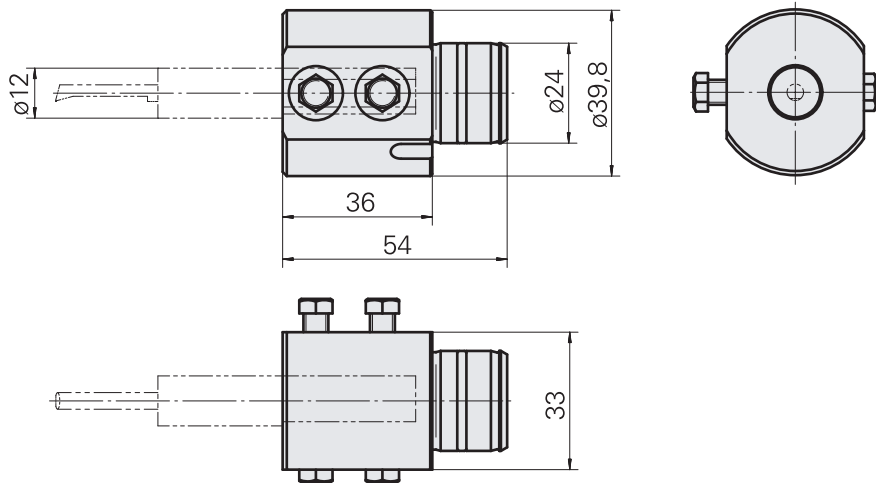

\* This article is included



## Mount

<b>Shank</b>	–
<b>Mounting</b>	D16
<b>Cooling</b>	internal, $p_{\max}$ 80 bar
<b>X / Y / Z</b>	36 (1.42) / – / – mm (")

### Matching base holder

Basic holder	W7040004
Basic holder	W7040005
Basic holder	W7040015
Basic holder	W7040088
Basic holder	W7040062
Basic holder	W7040086
Basic holder	W7040087
Basic holder	W7040040

### Matching accessories

Bush	W67511.04--
Clamping screw*	900804
Clamping screw*	900710

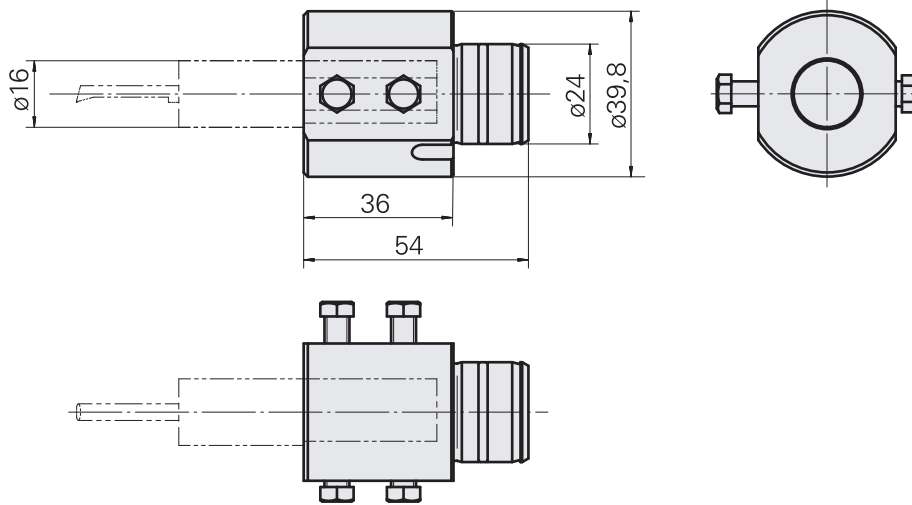

\* This article is included

## Mount

<b>Shank</b>	–
<b>Mounting</b>	D20
<b>Cooling</b>	internal, $p_{max}$ 80 bar
<b>X / Y / Z</b>	40 (1.57) / – / – mm (")

### Matching base holder

Basic holder	W7040004
Basic holder	W7040005
Basic holder	W7040015
Basic holder	W7040088
Basic holder	W7040062
Basic holder	W7040086
Basic holder	W7040087
Basic holder	W7040040

### Matching accessories

Bush	W68510.04--
Clamping screw*	900804
Clamping screw*	900710

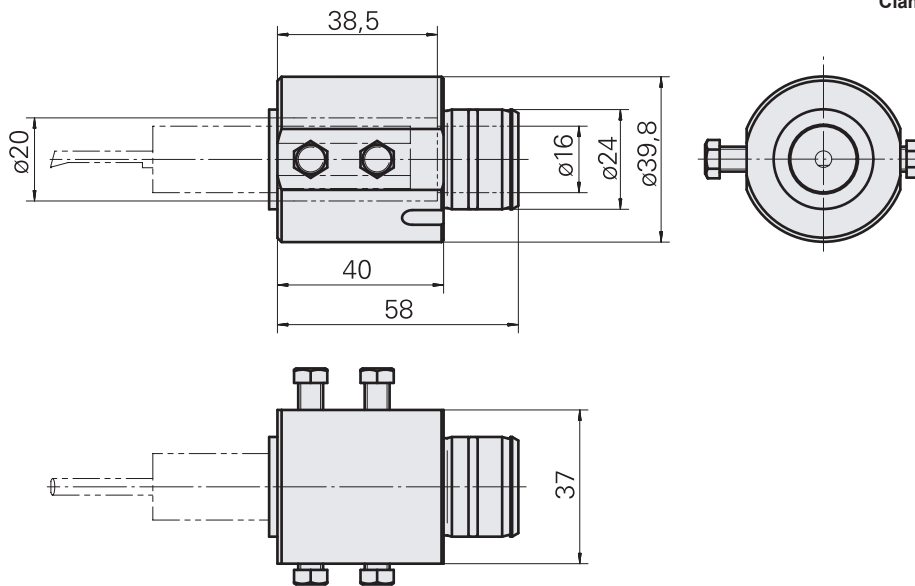

\* This article is included

## Mount

<b>Shank</b>	–
<b>Mounting</b>	D20
<b>Cooling</b>	internal, $p_{max}$ 80 bar
<b>X / Y / Z</b>	– / – / – mm (")

### Matching base holder

Basic holder	W7040062
Basic holder	W7040088
Basic holder	W7040086
Basic holder	W7040087

### Matching accessories

Bush	W68510.04--
------	-------------

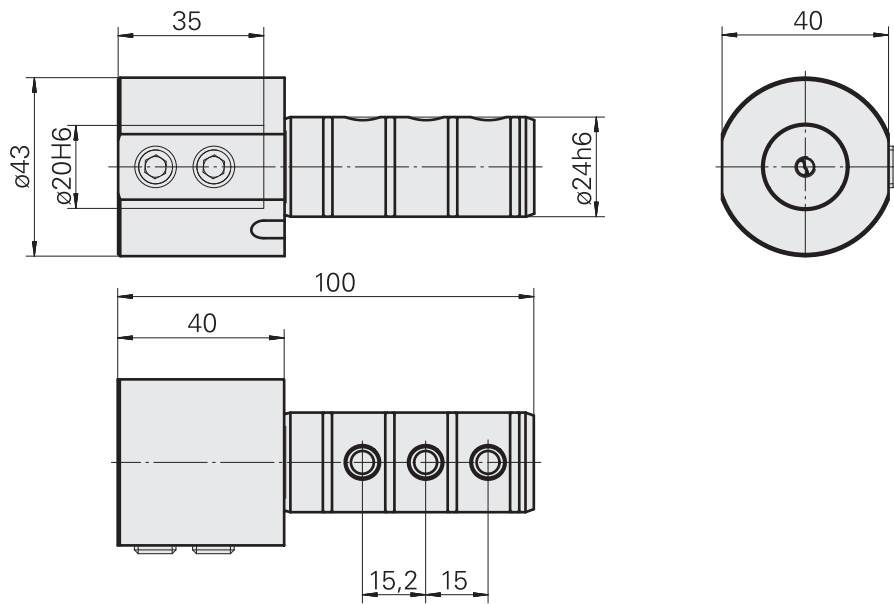

## Mount

<b>Shank</b>	–
<b>Mounting</b>	WFB 20-12
<b>Cooling</b>	internal, $p_{\max}$ 80 bar
<b>X / Y / Z</b>	19 (0.75) / – / – mm (")

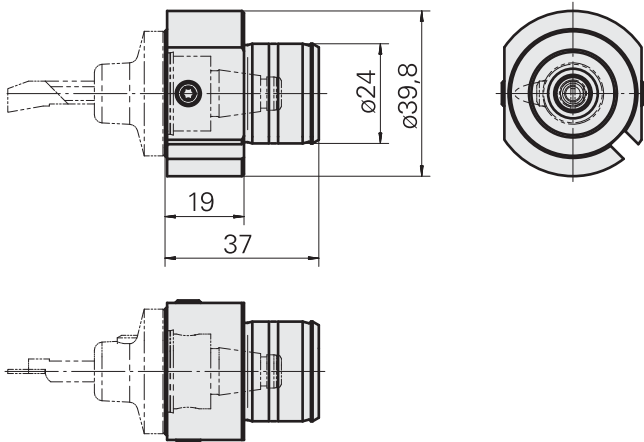

### Matching base holder

Basic holder	W7040004
Basic holder	W7040005
Basic holder	W7040015
Basic holder	W7040088
Basic holder	W7040062
Basic holder	W7040086
Basic holder	W7040087
Basic holder	W7040040

### Matching accessories

Grub screw*	326171
Screw	900783
WFB with shrink-fit mounting	904006
WFB with Weldon mounting	904007
WFB with collet mounting	904008
WFB with mill arbor mounting	904009
WFB hydr. expansion mounting	904010
WFB for Turning tool holder	904011
WFB for Horn S-Mini	904012
WFB for turning tool holder	904013
WFB for tap chuck	WZ9990.9613F
WFB miscellaneous mountings	WZ9990.9612F

### Other documents

Product note	<a href="#">W980009en</a>
--------------	---------------------------

\* This article is included

## Basic holder

<b>Shank</b>	Compact shank 45
<b>Mounting</b>	Hydraulic expansion chuck D12
<b>Cooling</b>	external and internal, $p_{max}$ 80 bar, internal 160 bar optional
<b>reversible 180°</b>	no
<b>X / Y / Z</b>	85 (3.35) / - / -75 (2.95) mm (")

### Matching accessories

<b>Bush*</b>	W9990911
<b>Hollow screw*</b>	W67530.0818
<b>Bush*</b>	W67530.0824
<b>Nozzle*</b>	W67500.3208
<b>Tube*</b>	W9990559

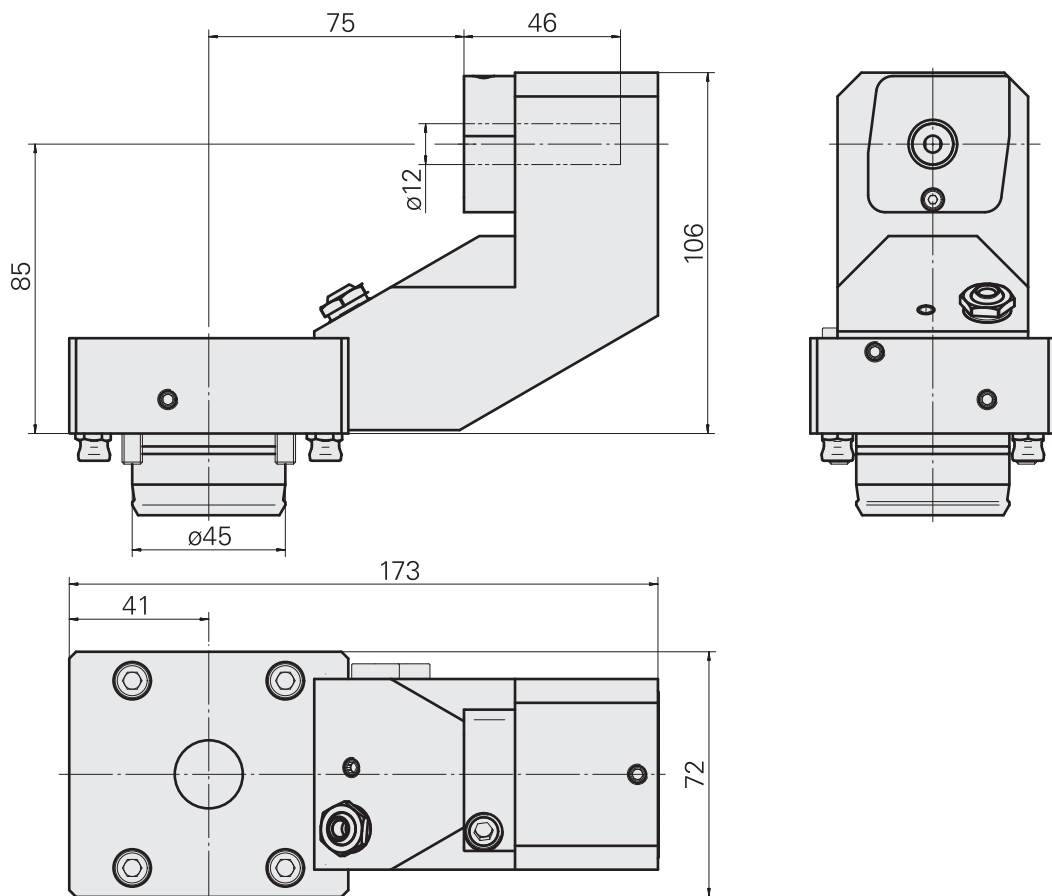

 Internal coolant supply with 160 bar is possible only on stations with an additional fluid-transfer station.

\* This article is included

## Basic holder

<b>Shank</b>	Compact shank 45
<b>Mounting</b>	INDEX TRAUB CAPTO C3
<b>Cooling</b>	internal, $p_{\max}$ 120 bar
<b>reversible 180°</b>	no
<b>X / Y / Z</b>	85 (3.35) / - / -71 (-2.8) mm (")

### Matching accessories

Quick-Change Insert	WZ9990.3000F
---------------------	--------------

### Other documents

Product note	W9800011en
--------------	------------

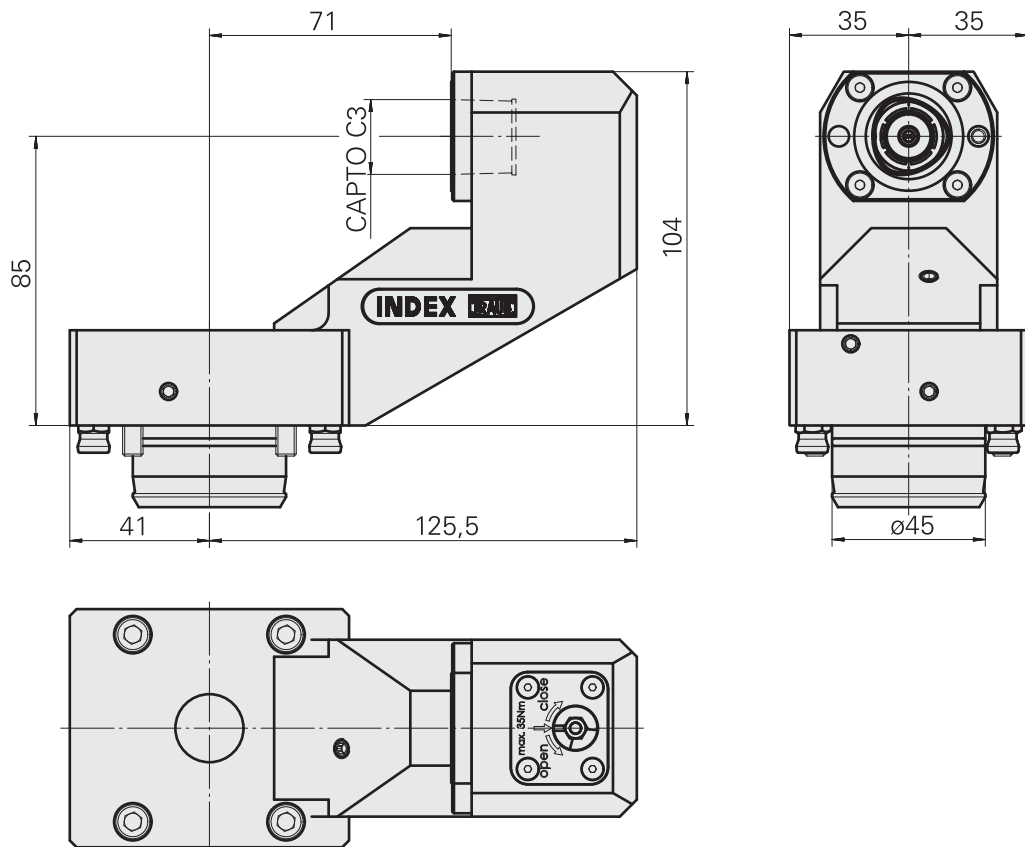

## Basic holder

<b>Shank</b>	Compact shank 45
<b>Mounting</b>	INDEX TRAUB CAPTO C3
<b>Cooling</b>	internal, $p_{max}$ 120 bar
<b>X / Y / Z</b>	85 (3.35) / - / 6 (0.24) mm (")

### Matching accessories

Quick-Change Insert	WZ9990.3000F
---------------------	--------------

### Other documents

Product note	<a href="#">W9800011en</a>
--------------	----------------------------

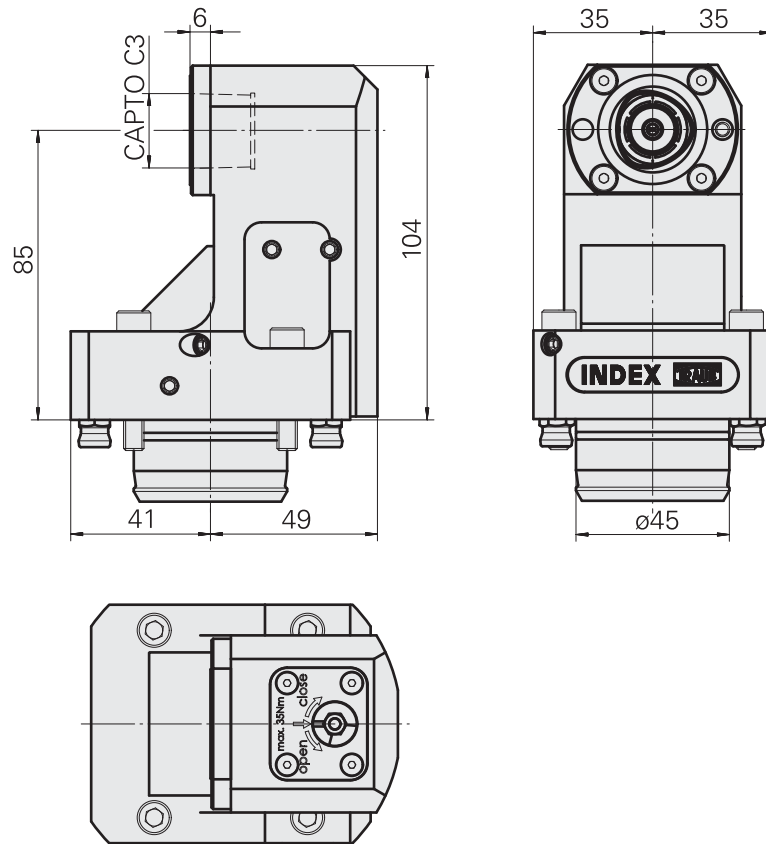



## Basic holder, angle-adjustable

<b>Shank</b>	Compact shank 45
<b>Mounting</b>	D28
<b>Cooling</b>	external, $p_{max}$ 80 bar
<b>X / Y / Z</b>	98 (3.86) / - / - mm (")

### Matching accessories

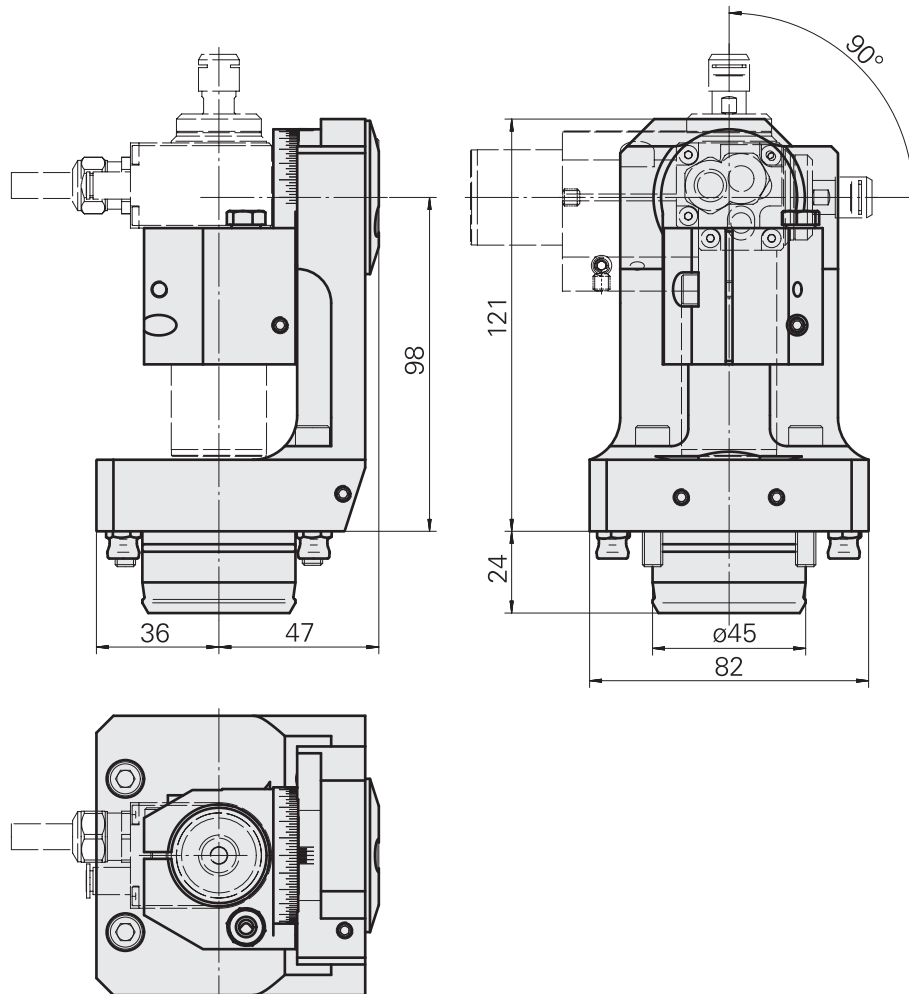
<b>Conical ring*</b>	314739
<b>Cap screw*</b>	314740
<b>Tube*</b>	W9990658
<b>Spindle Drive</b>	326548



 The machine has to be "Ready for High-Frequency spindle unit".

\* This article is included



## Closing tool holder, for rolling head of Fette

<b>Shank</b>	Compact shank 45
<b>Mounting</b>	D3/4"/D25
<b>Cooling</b>	external, $p_{\max}$ 80 bar
<b>reversible 180°</b>	no
<b>X / Y / Z</b>	81 (3.19) / - / -63 (-2.48) mm (")

<b>Matching modules</b>	
Thread rolling head	W9990109
Thread rolling head	W9990345

<b>Matching accessories</b>	
Multiple swivel joint*	314431
Conical ring*	314739
Cap screw*	314740
Tube*	W9990658

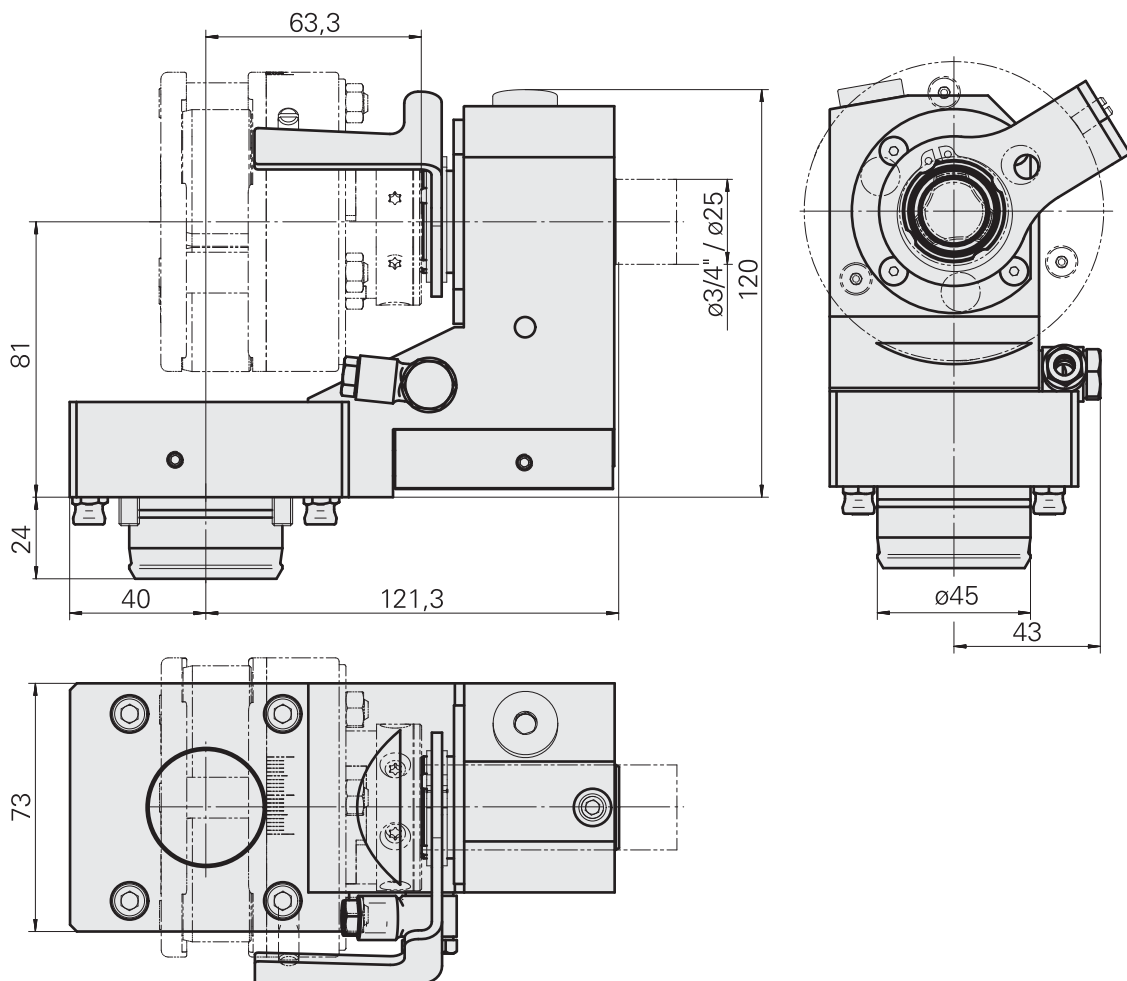

\* This article is included

## Closing tool holder, for rolling head of Fette

<b>Shank</b>	Compact shank 45
<b>Mounting</b>	D3/4"/D25
<b>Cooling</b>	external, $p_{\max}$ 80 bar
<b>reversible 180°</b>	no
<b>X / Y / Z</b>	81 (3.19) / - / 22.5 (0.89) mm (")

### Matching modules

Thread rolling head	W9990109
Thread rolling head	W9990345

### Matching accessories

Pipe connector*	470521.06
Ring*	471081.06
Spindle nose cap*	471161.06
Tube*	W9990559

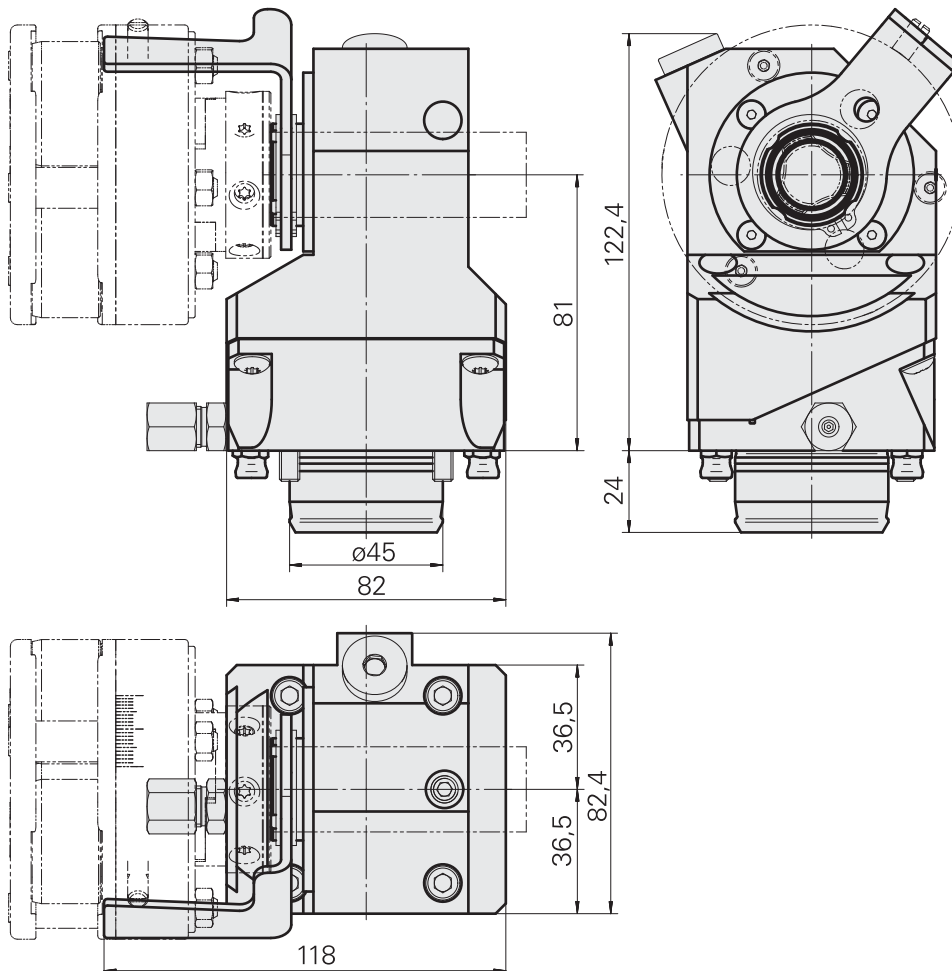

 Not suitable for machining on the main spindle of the TRAUB TNL18 and TNL32.

\* This article is included

## Closing tool holder, for rolling head of Wagner

<b>Shank</b>	Compact shank 45
<b>Mounting</b>	D3/4"/D25
<b>Cooling</b>	external, $p_{max}$ 80 bar
<b>reversible 180°</b>	no
<b>X / Y / Z</b>	81 (3.19) / - / -63 (-2.48) mm (")

<b>Matching modules</b>	
Thread rolling head	W9990342
Thread rolling head	W9990341

<b>Matching accessories</b>	
Multiple swivel joint*	314431
Conical ring*	314739
Cap screw*	314740
Tube*	818617

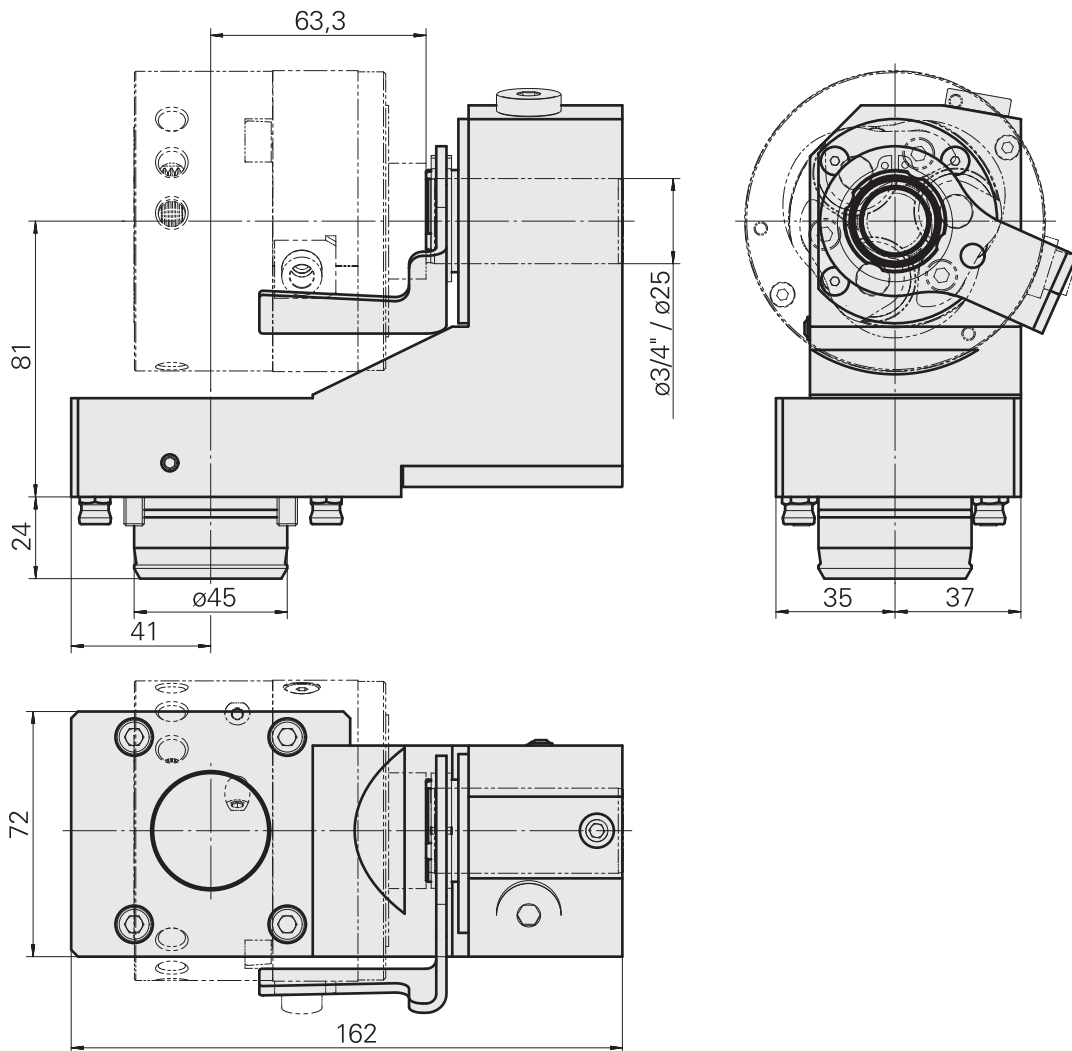



\* This article is included

## Closing tool holder, for rolling head of Wagner

<b>Shank</b>	Compact shank 45
<b>Mounting</b>	D3/4"/D25
<b>Cooling</b>	external, $p_{max}$ 80 bar
<b>reversible 180°</b>	no
<b>X / Y / Z</b>	96 (3.78) / - / 28 (1.10) mm (")

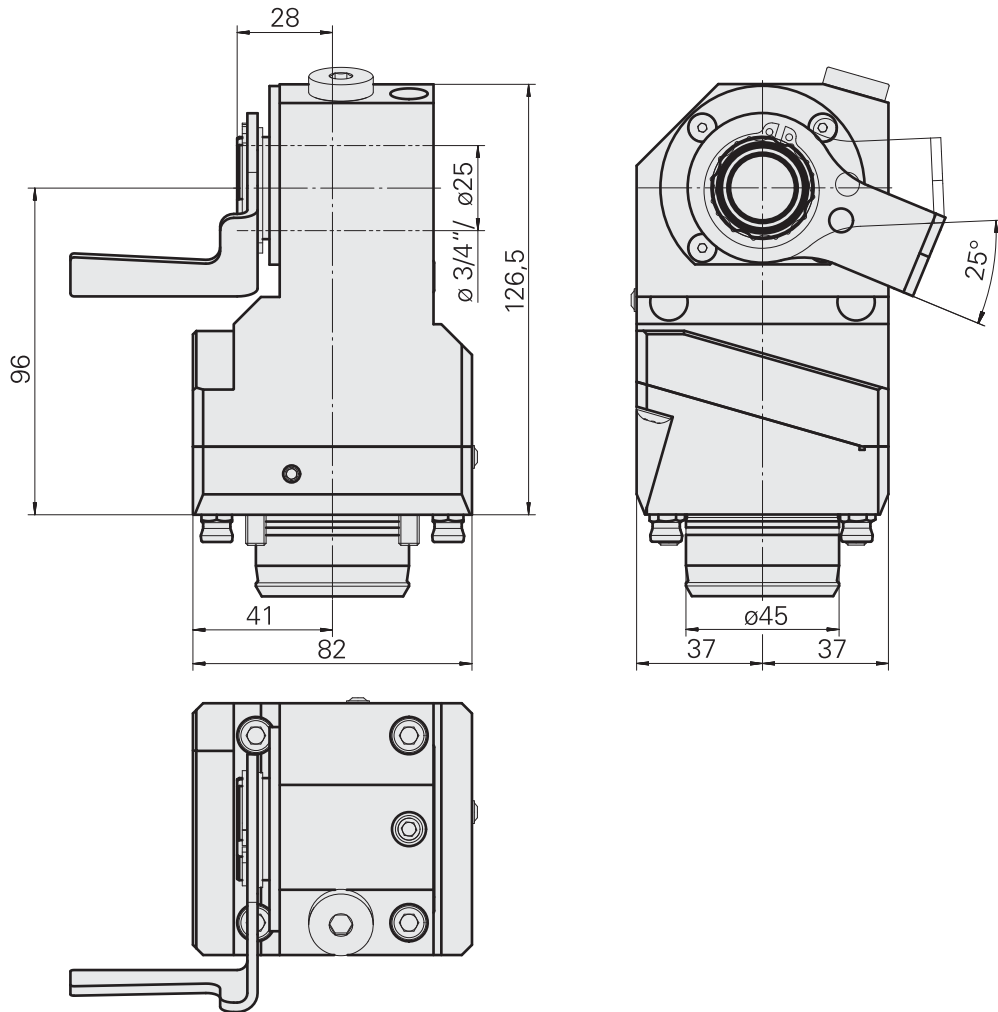
<b>Matching modules</b>	
Thread rolling head	W9990342
Thread rolling head	W9990341



 Not suitable for machining on the main spindle of the TRAUB TNL18 and TNL32.

## Receiving tray

Shank	Compact shank 45
Mounting	–
Cooling	–
reversible 180°	no
X / Y / Z	121 (4.76) / – / 80.5 (3.17) mm (")

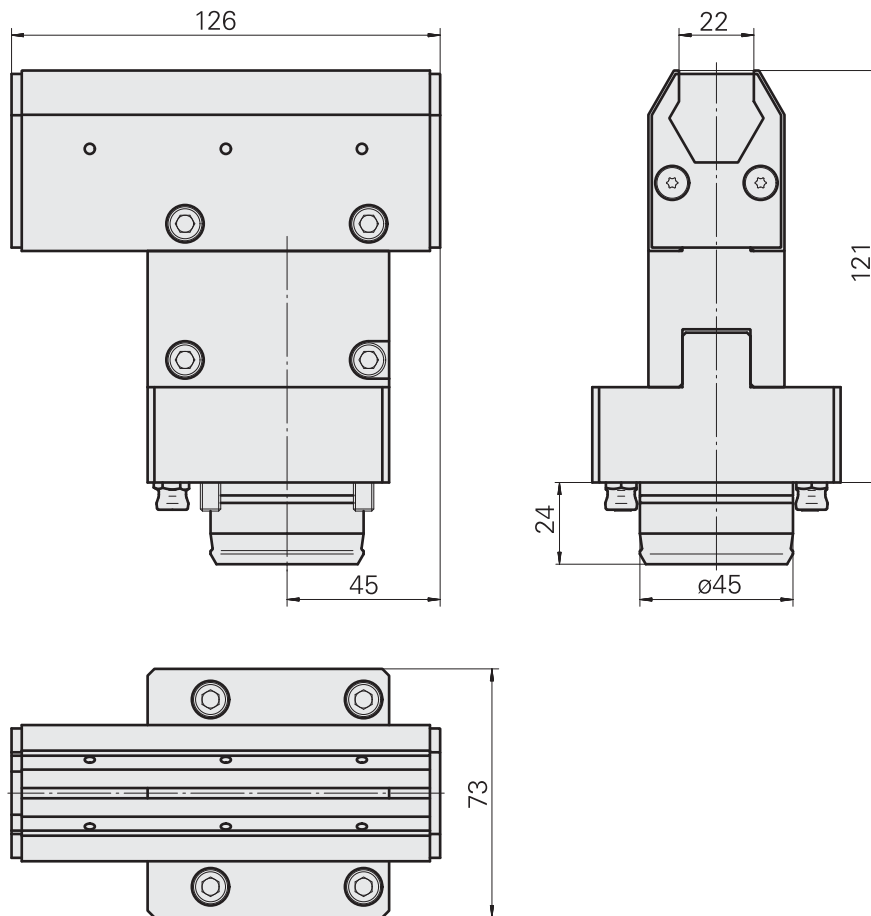

Specially for TRAUB TNL18-9 and TNL32-9.  
Only in conjunction with workpiece discharge unit and a hydraulic power unit.

## Gripper

<b>Shank</b>	Compact shank 45
<b>Mounting</b>	–
<b>Cooling</b>	–
<b>reversible 180°</b>	no
<b>X / Y / Z</b>	102 (42) / – / – mm (")

### Matching accessories

Set of jaws	904592
Set of jaws	901539
Set of jaws	910418
Set of jaws	910528
Set of jaws	908414

### Other documents

Product note	W9800007en
--------------	------------

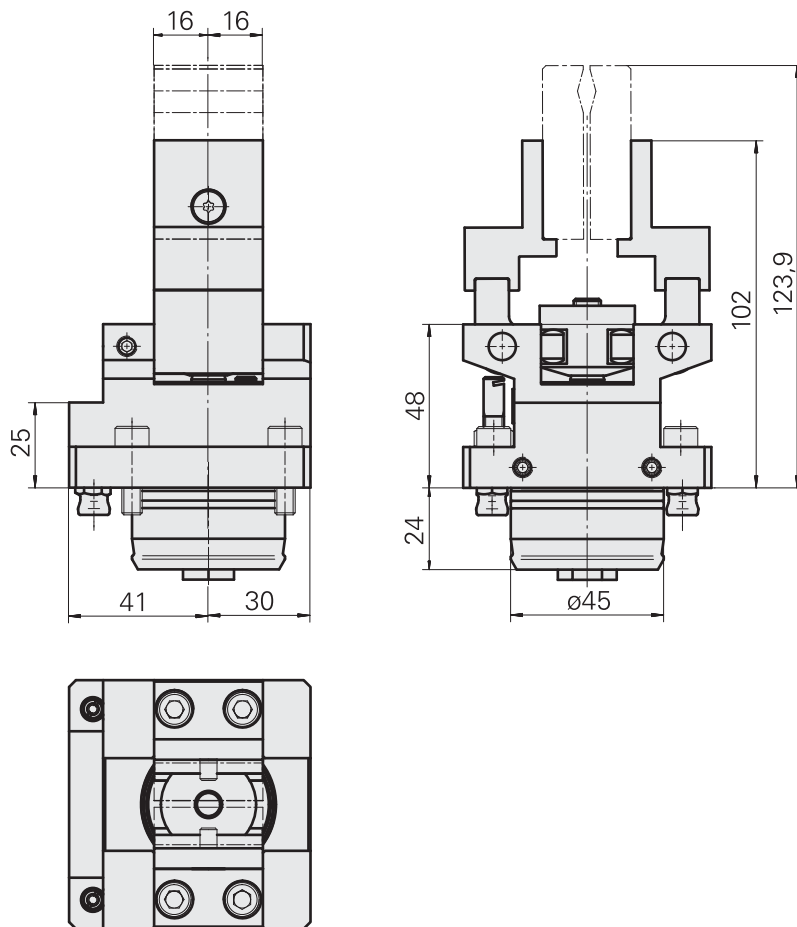

Specially for TRAUB TNL18-9 and TNL32-9.  
Only in conjunction with workpiece discharge unit and a hydraulic power unit.

## Blanking plug, Plastic

Shank	Compact shank 45
Mounting	–
Cooling	–
X / Y / Z	18 (0.71) / – / 0 mm (")

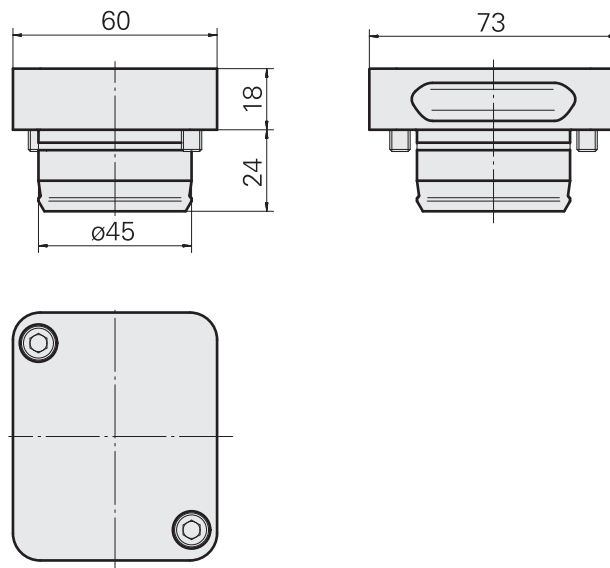





**Live Tool Holder**

**Turret Head**

**TRAUB TNL 18P**

**TRAUB TNL 18-7**

**TRAUB TNL 18-7B**

**TRAUB TNL 18-9**

## Drilling unit

<b>Shank</b>	Compact shank 45
<b>Drive</b>	Spur gear (18 Teeth)
<b>Mounting</b>	WFB 20-12
<b>Cooling</b>	external, $p_{max}$ 80 bar
<b>Speed ratio</b>	1:2.53 (0.395)
<b>Direction</b>	opposite to drive direction
<b>X / Y / Z</b>	84 (3.31) / - / 30 (1.18) mm (")

### Matching accessories

<b>Bush*</b>	W67530.0824
<b>Nozzle*</b>	W67500.3208
<b>Hollow screw*</b>	W67530.0818
<b>Tube*</b>	W9990559
<b>Nozzle</b>	W00019.0216
<b>WFB with shrink-fit mounting</b>	904006
<b>WFB with collet mounting</b>	904008
<b>Grub screw*</b>	326171

### Other documents

<b>Product note</b>	<a href="#">W9800009en</a>
---------------------	----------------------------

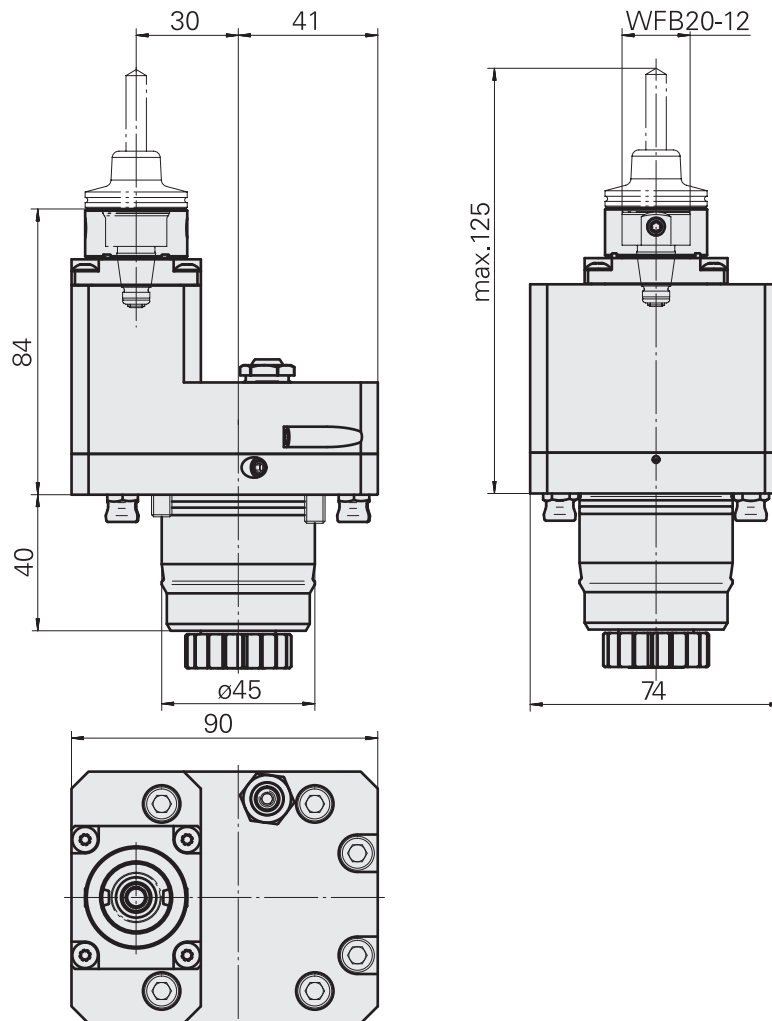

\* This article is included

## Drilling unit

<b>Shank</b>	Compact shank 45
<b>Drive</b>	Spur gear (18 Teeth)
<b>Mounting</b>	WFB 20-12
<b>Cooling</b>	external, $p_{max}$ 80 bar, internal 160 bar optional
<b>Speed ratio</b>	1:2.53 (0.395)
<b>Direction</b>	opposite to drive direction
<b>X / Y / Z</b>	84 (3.31) / - / 30 (1.18) mm (")

### Matching accessories

<b>Bush*</b>	W67530.0824
<b>Nozzle*</b>	W67500.3208
<b>Hollow screw*</b>	W67530.0818
<b>Tube*</b>	W9990559
<b>Nozzle</b>	W00019.0216
<b>WFB with shrink-fit mounting</b>	904006
<b>WFB with collet mounting</b>	904008
<b>Grub screw*</b>	326171

### Other documents

<b>Product note</b>	<a href="#">W980009en</a>
---------------------	---------------------------

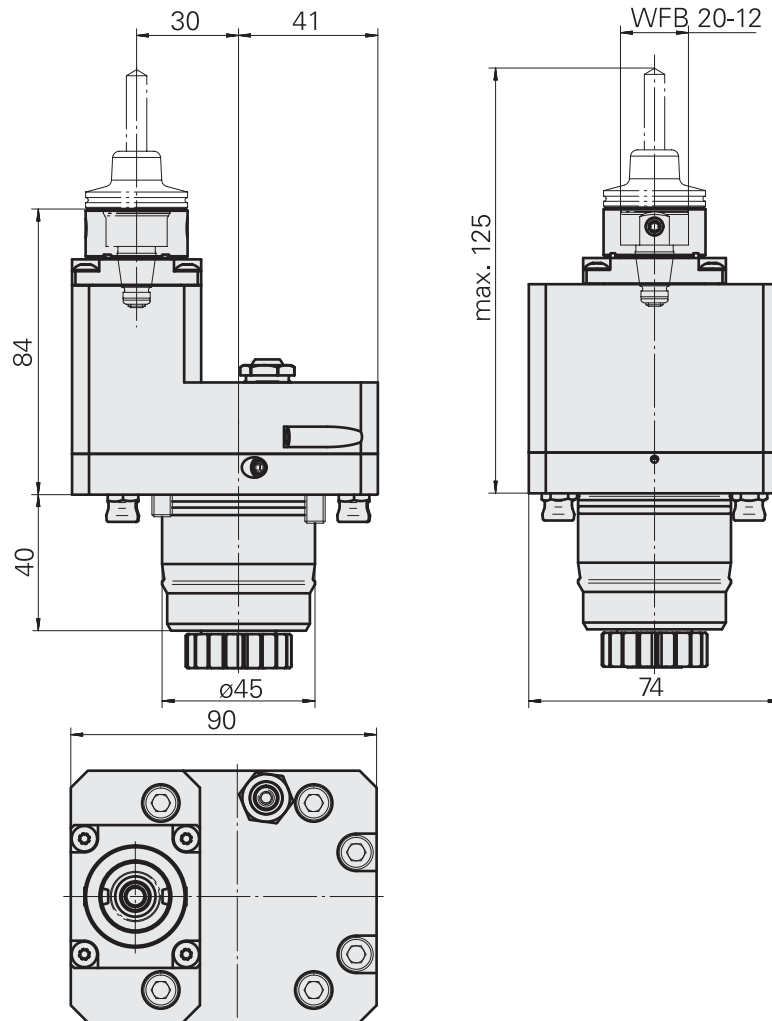

**i** Can be used only on stations 1 and 7 of the upper turret.  
Also, cooling lubricant supply with 80-120 bar is required.

\* This article is included

### Milling unit, double

<b>Shank</b>	Compact shank 45
<b>Drive</b>	Spur gear (18 Teeth)
<b>Mounting</b>	ER 11
<b>Cooling</b>	external, $p_{max}$ 80 bar
<b>Speed ratio</b>	1:1 (1)
<b>Direction</b>	opposite to drive direction
<b>X / Y / Z</b>	102.5 (44) / $\pm 13^\circ$ / - mm (")

### Matching accessories

Clamping collet	901930.0---
tapping tool collet	900288
tapping tool collet	3239--
Collet chuck	W999064-
Clamping nut*	322438
Bush	471112.06
Conical ring	471060.0601
Tube	W9990658
Spanner	490219.0111

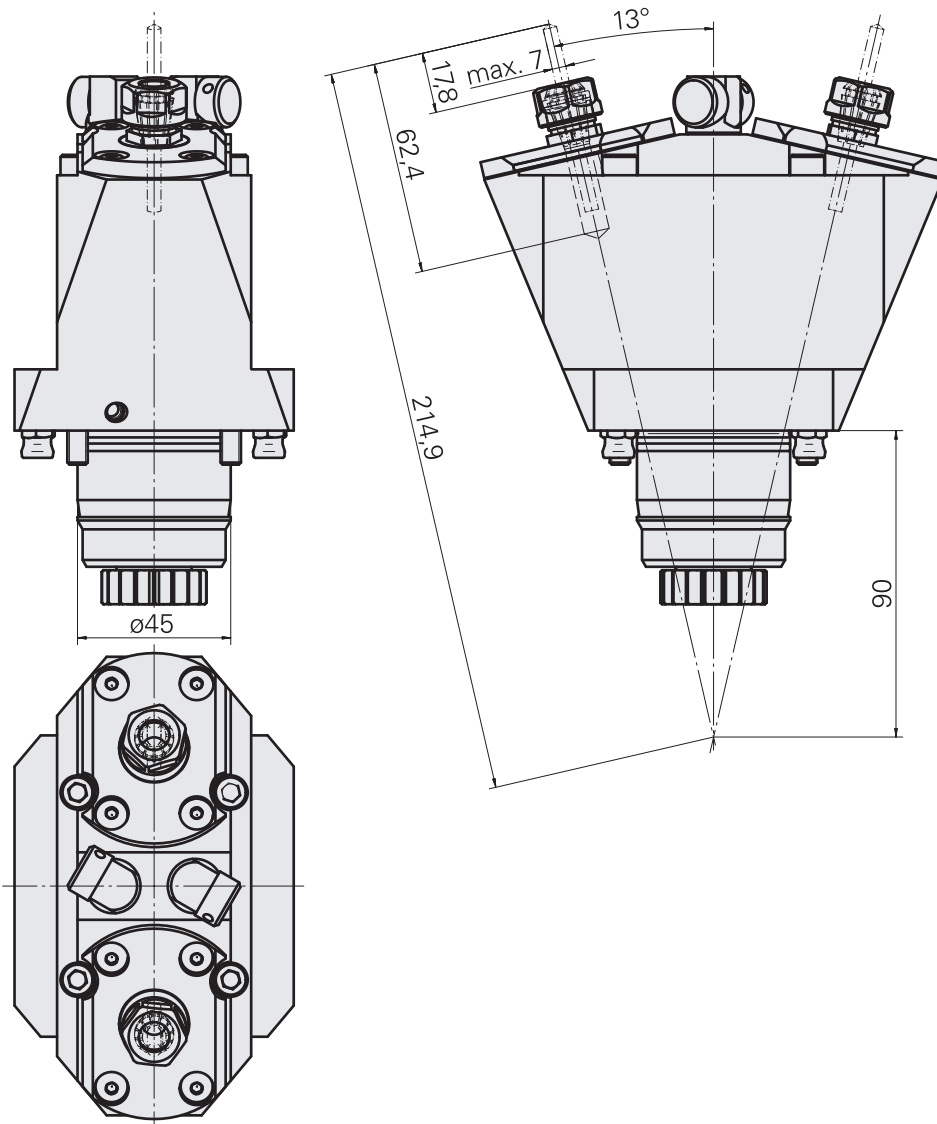

 Particularly suitable for the application on the circular axis.

\* This article is included

## Milling unit

<b>Shank</b>	Compact shank 45
<b>Drive</b>	Spur gear (18 Teeth)
<b>Mounting</b>	ER 16
<b>Cooling</b>	external, $p_{max}$ 80 bar
<b>Speed ratio</b>	1:1 (1)
<b>Direction</b>	same as drive direction
<b>X / Y / Z</b>	79 (3.11) / - / - mm (")

### Matching accessories

Clamping collet	W99903--
Clamping collet	901930.1--
tapping tool collet	3230--
tapping tool collet	WZ9990.9506F
Collet chuck	W999065-
Clamping collet, sealed	W999083-
Clamping nut*	901939.6161
Tube*	W9990658
Spanner	490219.2161

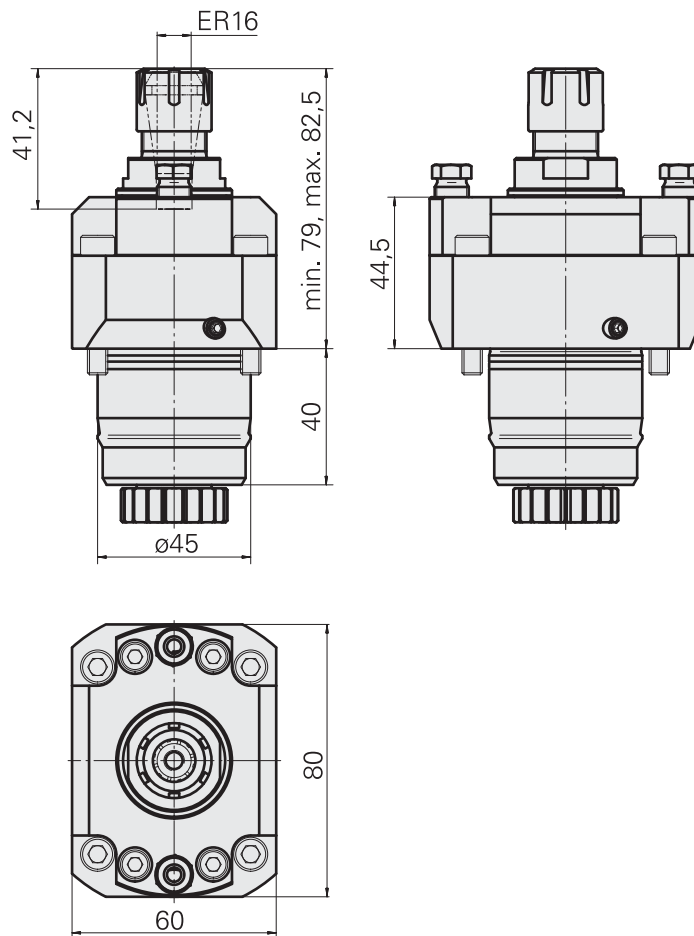

\* This article is included

## Milling unit

<b>Shank</b>	Compact shank 45
<b>Drive</b>	Spur gear (18 Teeth)
<b>Mounting</b>	WFB 20-12
<b>Cooling</b>	external, $p_{max}$ 80 bar
<b>Speed ratio</b>	1:1 (1)
<b>Direction</b>	same as drive direction
<b>X / Y / Z</b>	54 (2.13) / - / - mm (")

### Matching accessories

Conical ring*	314739
Cap screw*	314740
Tube*	W9990658
WFB with shrink-fit mounting	904006
WFB with Weldon mounting	904007
WFB with collet mounting	904008
WFB with mill arbor mounting	904009
WFB hydr. expansion mounting	904010
WFB for Turning tool holder	904011
WFB for tap chuck	WZ9990.9613F
WFB miscellaneous mountings	WZ9990.9612F
Grub screw*	326171

### Other documents

Product note	<a href="#">W980009en</a>
--------------	---------------------------

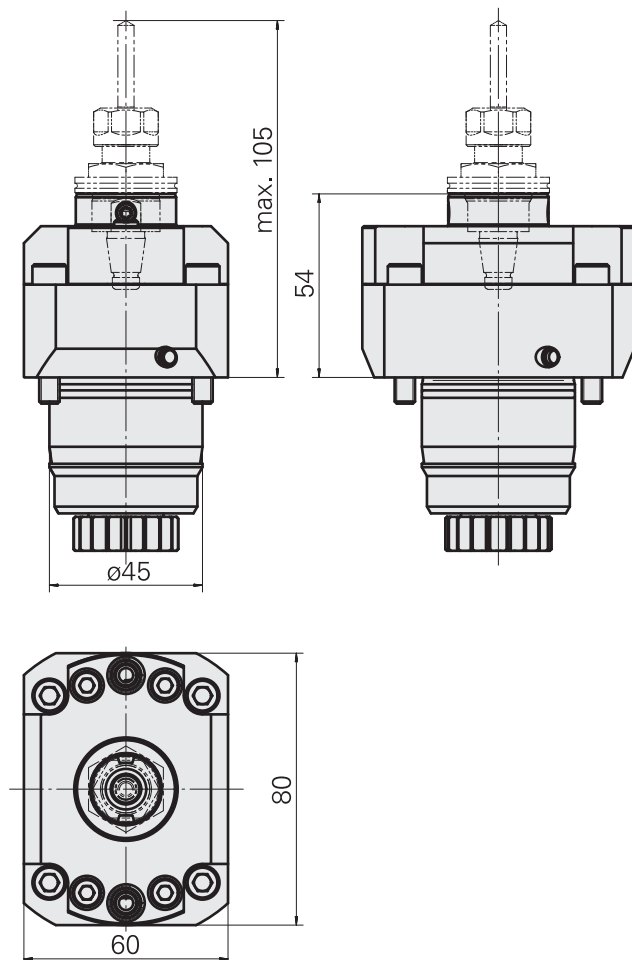

\* This article is included

## Milling unit, double

<b>Shank</b>	Compact shank 45
<b>Drive</b>	Spur gear (18 Teeth)
<b>Mounting</b>	WFB 20-12
<b>Cooling</b>	external, $p_{max}$ 80 bar
<b>Speed ratio</b>	1:1 (1)
<b>Direction</b>	opposite to drive direction
<b>X / Y / Z</b>	102 (42) / $\pm 13^\circ$ / 0 mm (")

### Matching accessories

Nozzle	326648
Conical ring	471060.0601
Tube	W9990658
WFB with shrink-fit mounting	904006
WFB with Weldon mounting	904007
WFB with collet mounting	904008
WFB with mill arbor mounting	904009
WFB hydr. expansion mounting	904010
WFB for tap chuck	WZ9990.9613F
WFB miscellaneous mountings	WZ9990.9612F
Grub screw*	326171

### Other documents

Product note	<a href="#">W9800009en</a>
--------------	----------------------------

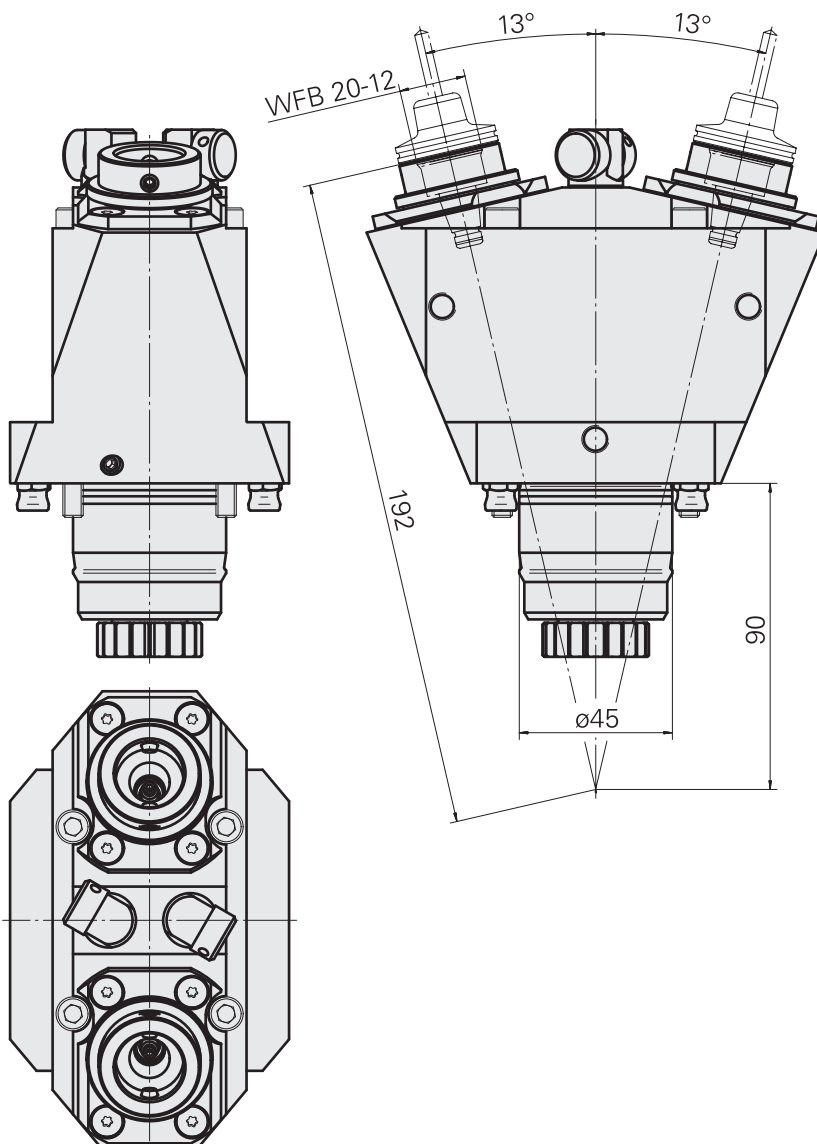

 Particularly suitable for the application on the circular axis.

\* This article is included

## Milling unit

<b>Shank</b>	Compact shank 45
<b>Drive</b>	Spur gear (18 Teeth)
<b>Mounting</b>	INDEX TRAUB CAPTO C3
<b>Cooling</b>	external, $p_{max}$ 80 bar
<b>Speed ratio</b>	1:1 (1)
<b>Direction</b>	same as drive direction
<b>reversible 180°</b>	no
<b>X / Y / Z</b>	56 (2.2) / - / 0 mm (")

### Matching accessories

Coolant nozzle*	W00019.0153
Tube*	W00019.0164
Quick-Change Insert	WZ9990.3000F

### Other documents

Product note	<a href="#">W9800010en</a>
--------------	----------------------------

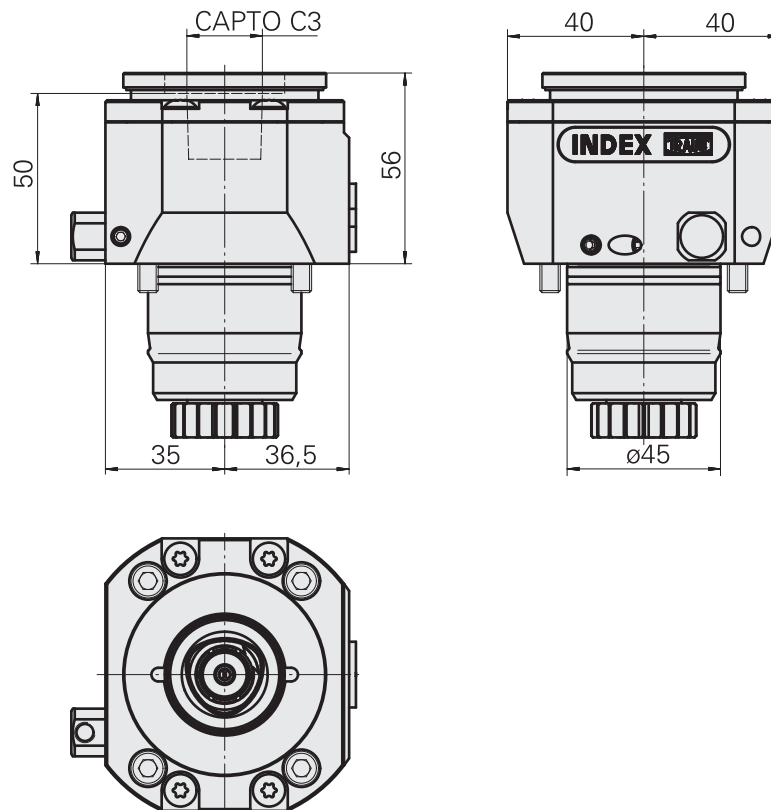

\* This article is included



### Circular saw unit

<b>Shank</b>	Compact shank 45
<b>Drive</b>	Spur gear (18 Teeth)
<b>Mounting</b>	Milling tool mounting D22
<b>Cooling</b>	external, $p_{max}$ 80 bar
<b>Speed ratio</b>	8.1:1 (8.1)
<b>Direction</b>	same as drive direction
<b>reversible 180°</b>	no
<b>X / Y / Z</b>	81.5 (3.21) / - / 4 (0.16) mm (")

### Matching cutting tools

<b>Drawing</b>	901328
----------------	--------

### Matching accessories

<b>Multiple swivel joint*</b>	314431
<b>Conical ring*</b>	314739
<b>Cap screw*</b>	314740
<b>Tube*</b>	W9990658

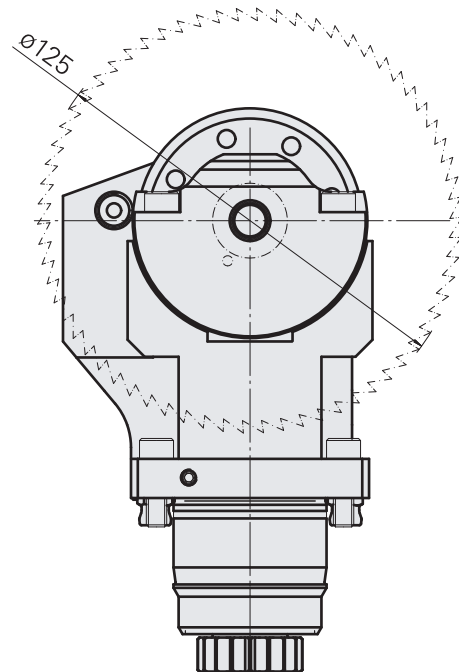
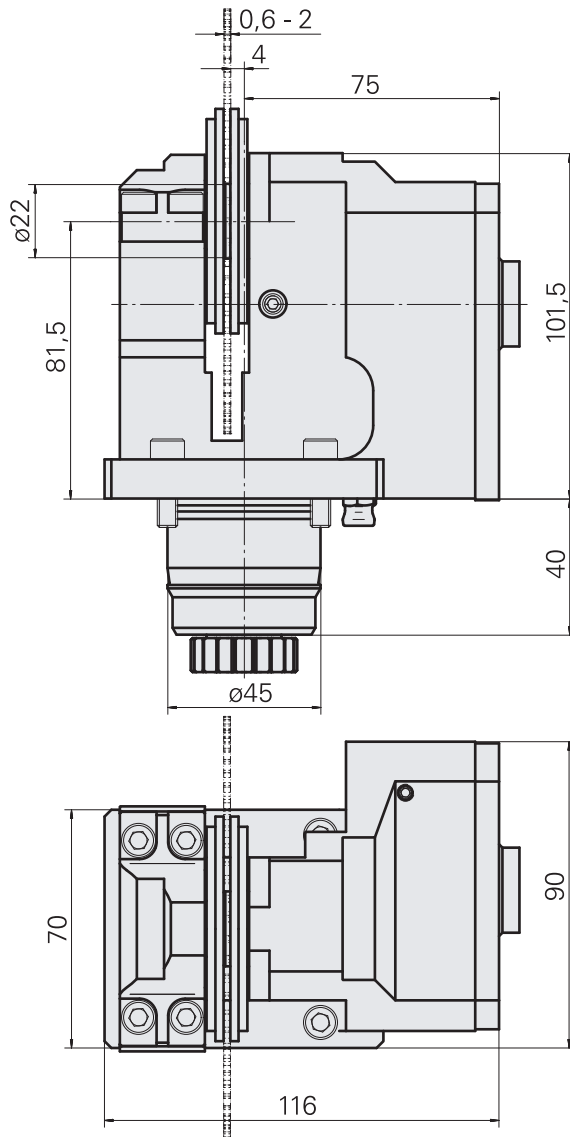

 The sawblade diameter must be 125 mm.

\* This article is included

## Gear cutting unit

<b>Shank</b>	Compact shank 45
<b>Drive</b>	Spur gear (18 Teeth)
<b>Mounting</b>	–
<b>Cooling</b>	external, $p_{\max}$ 80 bar
<b>Speed ratio</b>	3:1 (3)
<b>Direction</b>	opposite to drive direction
<b>X / Y / Z</b>	92 (3.62) / – / – mm (")

### Matching modules

Rear bearing support	W9990352
Rear bearing support	W9990353

### Matching accessories

Multiple swivel joint*	314431
Conical ring*	314739
Cap screw*	314740
Tube*	W9990658

### Other documents

Product note	W9800013en
--------------	------------

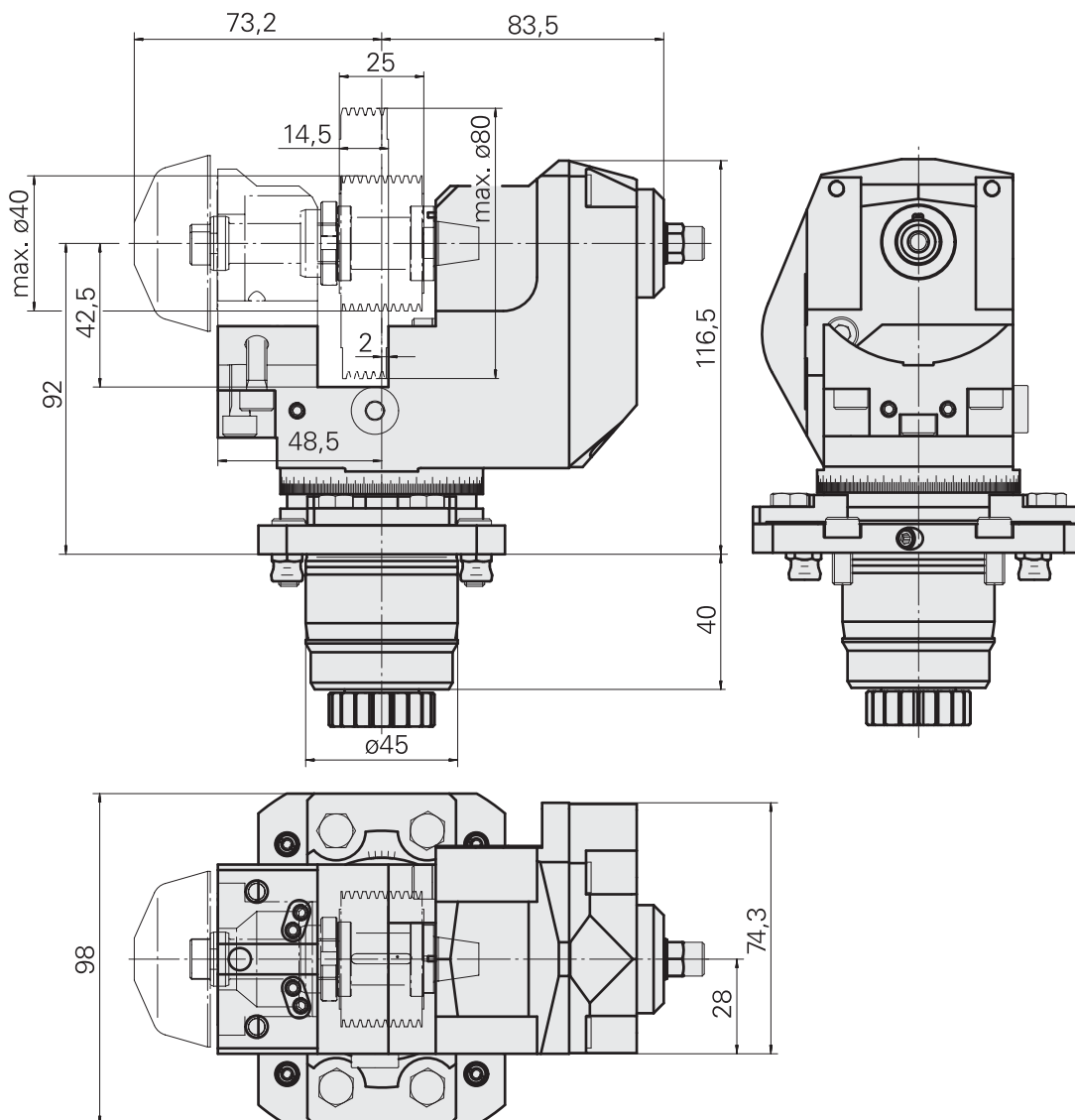

 Adjacent stations can only be used to a limited extent.

\* This article is included

## Drilling unit

<b>Shank</b>	Compact shank 45
<b>Drive</b>	Spur gear (18 Teeth)
<b>Mounting</b>	WFB 20-12
<b>Cooling</b>	external, internal optional, $p_{max}$ 160 bar
<b>Speed ratio</b>	1:1.66 (0.6)
<b>Direction</b>	opposite to drive direction
<b>reversible 180°</b>	no
<b>X / Y / Z</b>	95 (3.74) / - / -40 (-1.57) mm (")

### Matching accessories

IC-attachment up to 160bar	W9990980
Nozzle*	W67500.3208
Hollow screw*	W67530.0818
Bush*	W67530.0824
Tube*	W9990559
Nozzle	W00019.0216
WFB with shrink-fit mounting	904006
WFB with collet mounting	904008
Grub screw	326171

### Other documents

Product note	<a href="#">W980009en</a>
--------------	---------------------------

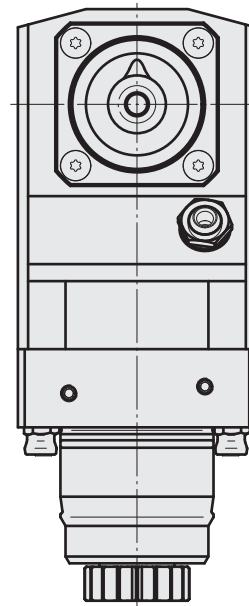
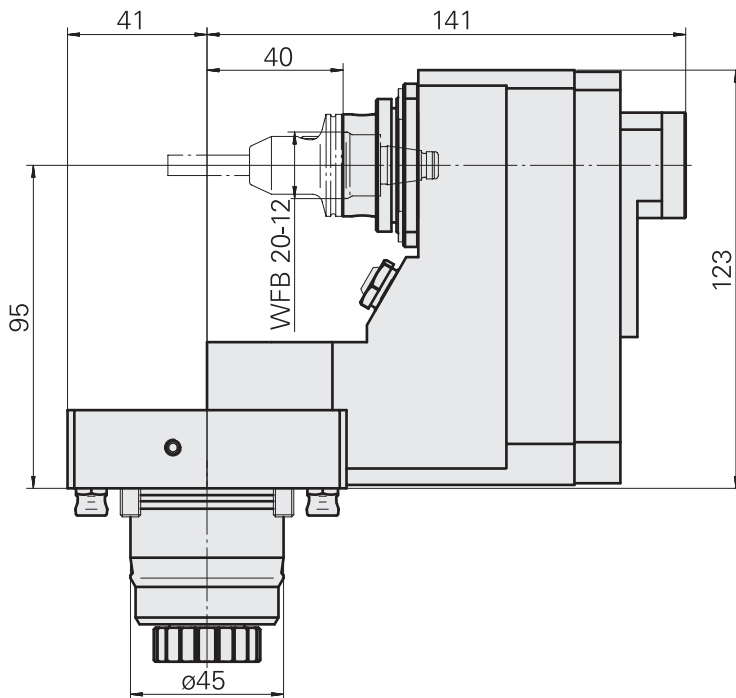

Can be used only on stations 1 and 7 of the upper turret.  
Also, cooling lubricant supply with 80-120 bar is required.

\* This article is included

## Drilling unit

<b>Shank</b>	Compact shank 45
<b>Drive</b>	Spur gear (18 Teeth)
<b>Mounting</b>	WFB 20-12
<b>Cooling</b>	external, $p_{max}$ 80 bar, internal 160 bar optional
<b>Speed ratio</b>	1:1 (1)
<b>Direction</b>	opposite to drive direction
<b>reversible 180°</b>	no
<b>X / Y / Z</b>	95 (3.74) / - / -60 (-2.36) mm (")

### Matching accessories

Tube*	W9990658
WFB with shrink-fit mounting	904006
WFB with Weldon mounting	904007
WFB with collet mounting	904008
WFB hydr. expansion mounting	904010
WFB for Turning tool holder	904011
WFB for tap chuck	WZ9990.9613F
WFB miscellaneous mountings	WZ9990.9612F
Grub screw*	326171

### Other documents

Product note	<a href="#">W980009en</a>
--------------	---------------------------

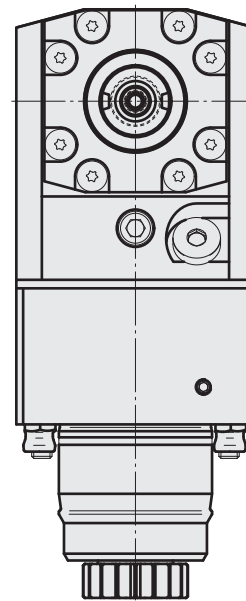
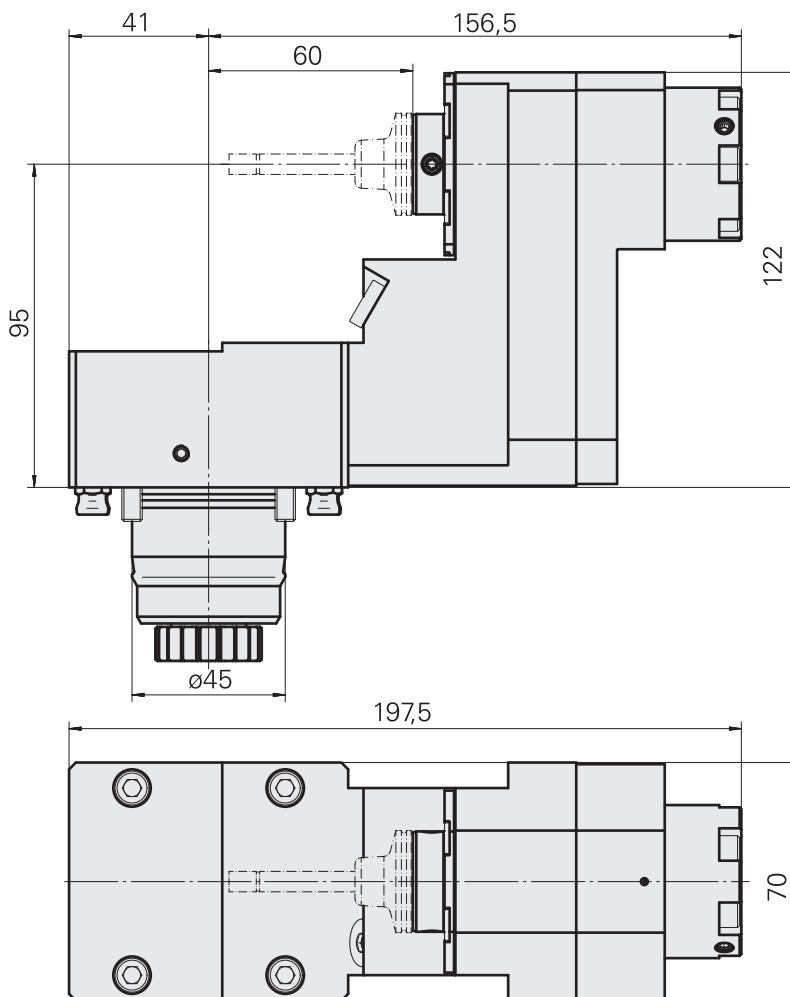

Can be used only on stations 1 and 7 of the upper turret.  
Also, cooling lubricant supply with 80-120 bar is required.

\* This article is included

## Milling unit

<b>Shank</b>	Compact shank 45
<b>Drive</b>	Spur gear (18 Teeth)
<b>Mounting</b>	ER 16
<b>Cooling</b>	external and internal, $p_{max}$ 80 bar
<b>Speed ratio</b>	1:1 (1)
<b>Direction</b>	opposite to drive direction
<b>reversible 180°</b>	no
<b>X / Y / Z</b>	95 (3.74) / - / -40 (-1.57) mm (")

### Matching accessories

Clamping collet	901930.1---
Clamping collet	W99903--
tapping tool collet	3230--
tapping tool collet	WZ9990.9506F
Collet chuck	W999065-
Clamping collet, sealed	W999083-
Clamping nut*	901939.6161
Hollow screw*	W67530.0818
Bush*	W67530.0824
Nozzle*	W67500.3208
Nozzle*	W00019.0216
Spanner	490219.2161

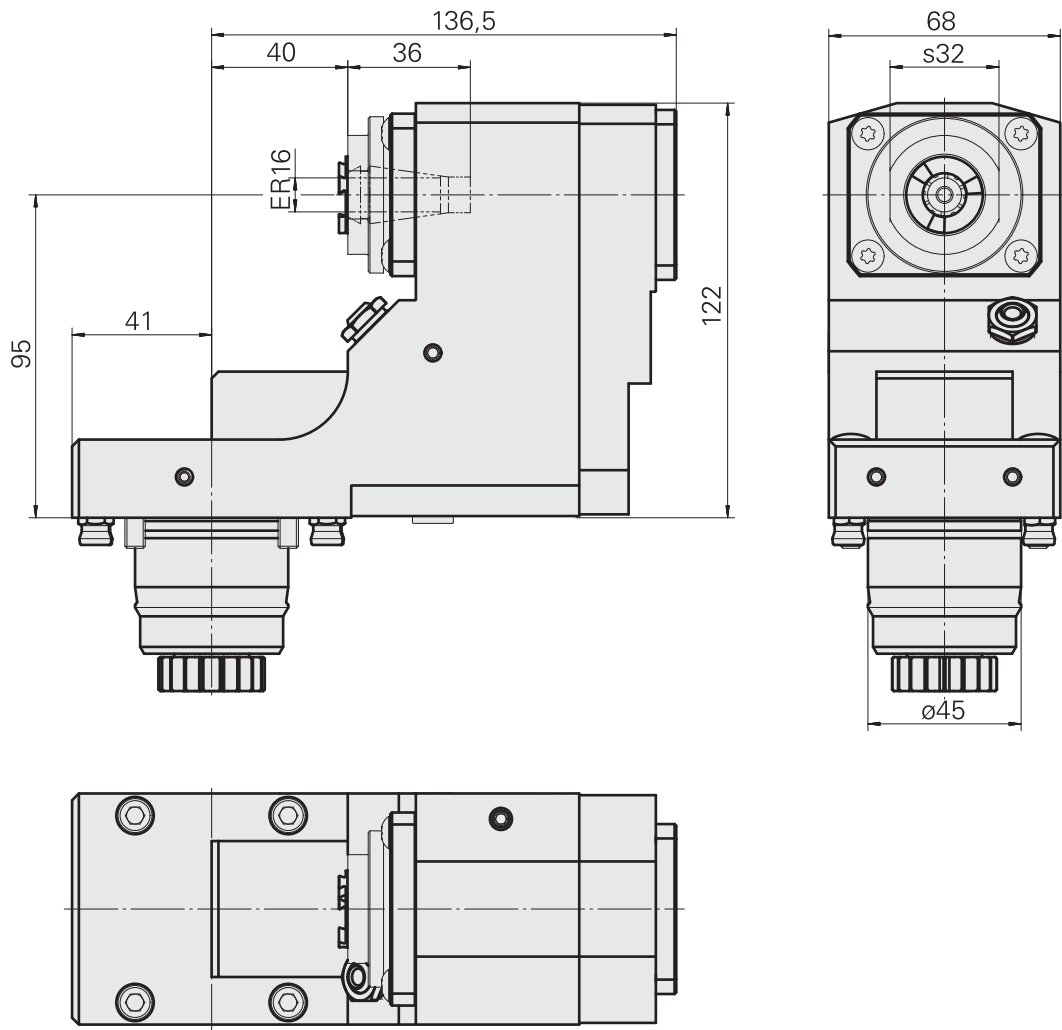

\* This article is included

**Milling unit, double**

<b>Shank</b>	Compact shank 45
<b>Drive</b>	Spur gear (18 Teeth)
<b>Mounting</b>	ER 16
<b>Cooling</b>	external, internal optional, $p_{max}$ 80 bar
<b>Speed ratio</b>	1:1 (1)
<b>Direction</b>	opposite to drive direction
<b>X / Y / Z</b>	95 (3.74) / $\pm 13^\circ$ / 55 (2.17) mm (")

**Matching accessories**

Clamping collet	901930.1---
Clamping collet, sealed	W999083-
tapping tool collet	3230--
tapping tool collet	WZ9990.9506F
Collet chuck	W999065-
Clamping nut*	901939.5161
IC-attachment up to 80bar	W9990290
Bush*	W67530.0824
Hollow screw*	W67530.0818
Nozzle*	W67500.3208
Tube*	W9990559
Spanner	490219.3161

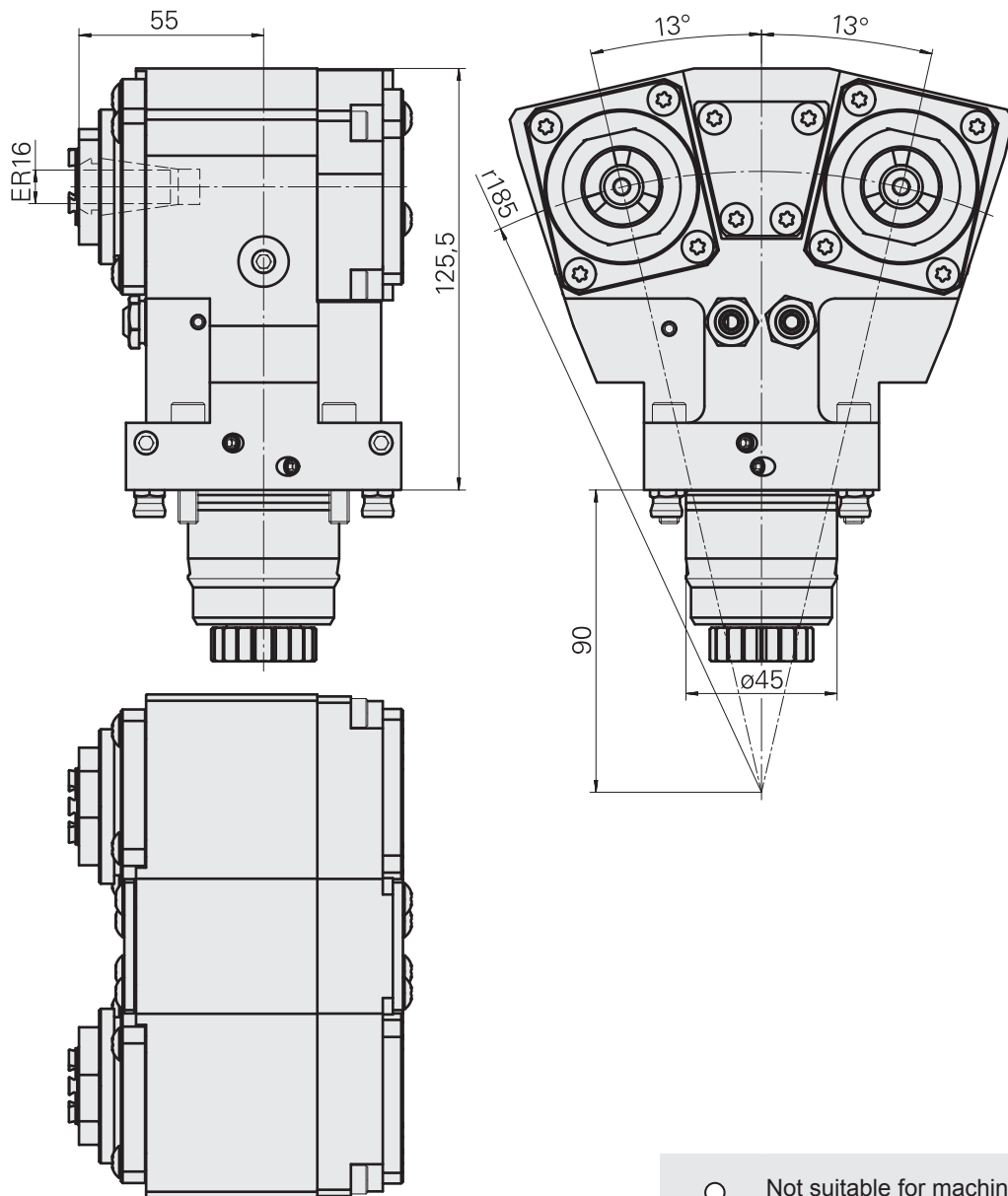

**i** Not suitable for machining on the main spindle of the TRAUB TNL18 and TNL32.

\* This article is included

## Milling unit, double

<b>Shank</b>	Compact shank 45
<b>Drive</b>	Spur gear (18 Teeth)
<b>Mounting</b>	WFB 20-12
<b>Cooling</b>	external, internal optional, $p_{max}$ 80 bar
<b>Speed ratio</b>	1:1.08 (0.93)
<b>Direction</b>	opposite to drive direction
<b>reversible 180°</b>	no
<b>X / Y / Z</b>	95 (3.74) / $\pm 13^\circ$ / -37 (-1.46) mm (")

### Matching accessories

IC-attachment up to 160bar	W9990284
IC-attachment up to 80bar	W9990290
Bush*	W67530.0824
Hollow screw*	W67530.0818
Nozzle*	W67500.3208
Nozzle	W00019.0216
Tube*	W9990559
WFB with shrink-fit mounting	904006
WFB with Weldon mounting	904007
WFB with collet mounting	904008
WFB with mill arbor mounting	904009
WFB hydr. expansion mounting	904010
WFB for Turning tool holder	904011
WFB for tap chuck	WZ9990.9613F
WFB miscellaneous mountings	WZ9990.9612F
Grub screw*	326171

### Other documents

Product note

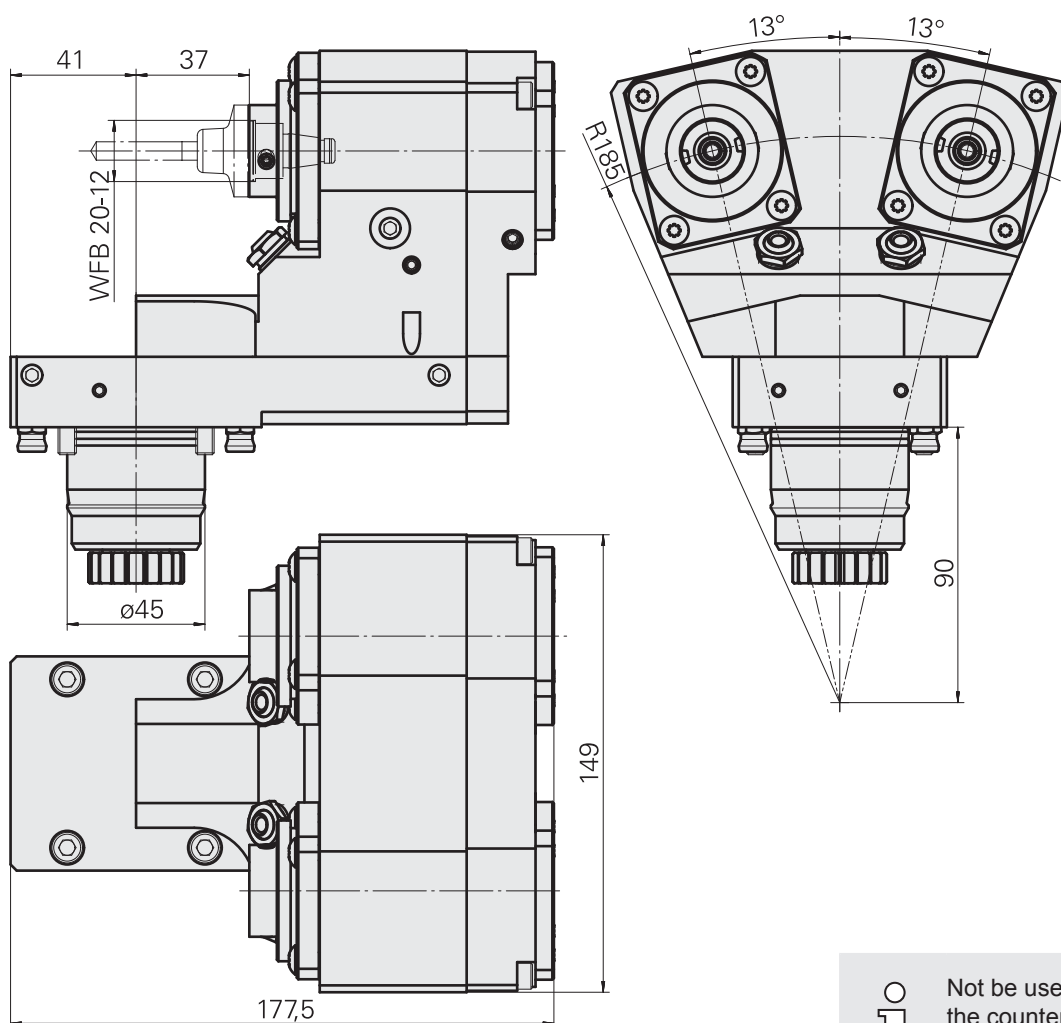
[W9800009en](#)

Not be used directly next to the counter spindle.

\* This article is included

## Milling unit

<b>Shank</b>	Compact shank 45
<b>Drive</b>	Spur gear (18 Teeth)
<b>Mounting</b>	WFB 20-12
<b>Cooling</b>	external, $p_{max}$ 80 bar
<b>Speed ratio</b>	1:1 (1)
<b>Direction</b>	same as drive direction
<b>reversible 180°</b>	no
<b>X / Y / Z</b>	95 (3.74) / - / 44 (1.73) mm (")

## Matching accessories

Tube*	W9990658
WFB with shrink-fit mounting	904006
WFB with Weldon mounting	904007
WFB with collet mounting	904008
WFB with mill arbor mounting	904009
WFB hydr. expansion mounting	904010
WFB for Turning tool holder	904011
WFB for tap chuck	WZ9990.9613F
WFB miscellaneous mountings	WZ9990.9612F
Grub screw*	326171

## Other documents

Product note

[W9800009en](#)

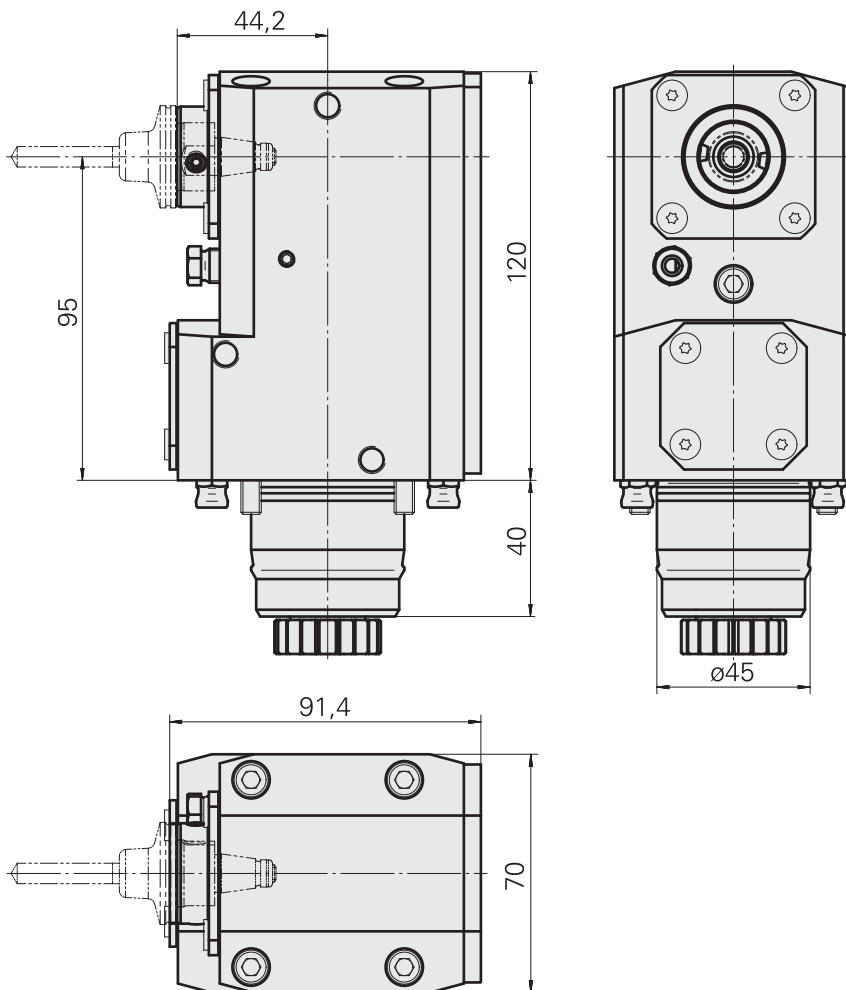

 Not suitable for machining on the main spindle of the TRAUB TNL18 and TNL32.

\* This article is included



## Milling unit

<b>Shank</b>	Compact shank 45
<b>Drive</b>	Spur gear (18 Teeth)
<b>Mounting</b>	WFB 20-12
<b>Cooling</b>	external and internal, $p_{\max}$ 80 bar
<b>Speed ratio</b>	1:1 (1)
<b>Direction</b>	opposite to drive direction
<b>reversible 180°</b>	no
<b>X / Y / Z</b>	95 (3.74) / - / -37 (-1.46) mm (")

## Matching accessories

Hollow screw*	W67530.0818
Bush*	W67530.0824
Nozzle*	W67500.3208
Nozzle	W00019.0216
WFB with shrink-fit mounting	904006
WFB with Weldon mounting	904007
WFB with collet mounting	904008
WFB with mill arbor mounting	904009
WFB hydr. expansion mounting	904010
WFB for Turning tool holder	904011
WFB for tap chuck	WZ9990.9613F
WFB miscellaneous mountings	WZ9990.9612F
Grub screw*	326171

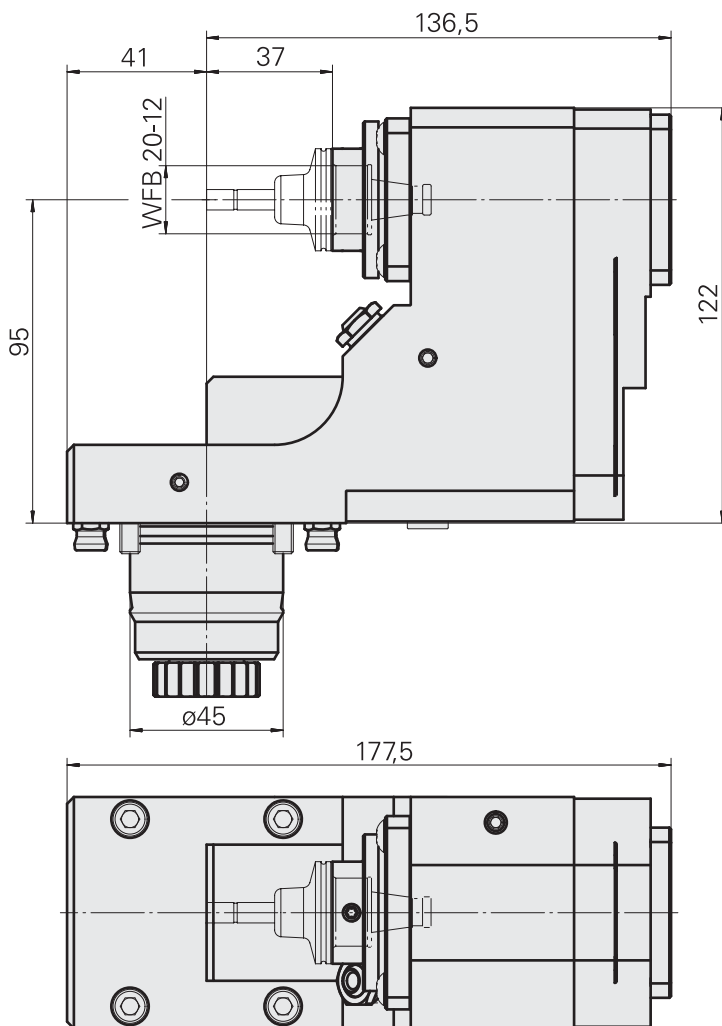

## Other documents

Product note

W9800009en

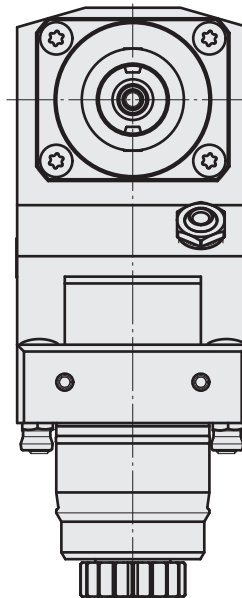

 For internal cooling, dry running is permitted during setup of the workpiece only!

\* This article is included

## Milling unit, double

<b>Shank</b>	Compact shank 45
<b>Drive</b>	Spur gear (18 Teeth)
<b>Mounting</b>	WFB 20-12
<b>Cooling</b>	external, internal optional, $p_{max}$ 80 bar
<b>Speed ratio</b>	1:1 (1)
<b>Direction</b>	opposite to drive direction
<b>X / Y / Z</b>	95 (3.74) / $\pm 13^\circ$ / 58 (2.28) mm (")

### Matching accessories

IC-attachment up to 80bar	W9990290
Bush*	W67530.0824
Hollow screw*	W67530.0818
Nozzle*	W67500.3208
Tube*	W9990559
WFB with shrink-fit mounting	904006
WFB with Weldon mounting	904007
WFB with collet mounting	904008
WFB with mill arbor mounting	904009
WFB hydr. expansion mounting	904010
WFB for Turning tool holder	904011
WFB for tap chuck	WZ9990.9613F
WFB miscellaneous mountings	WZ9990.9612F
Grub screw*	326171

### Other documents

Product note

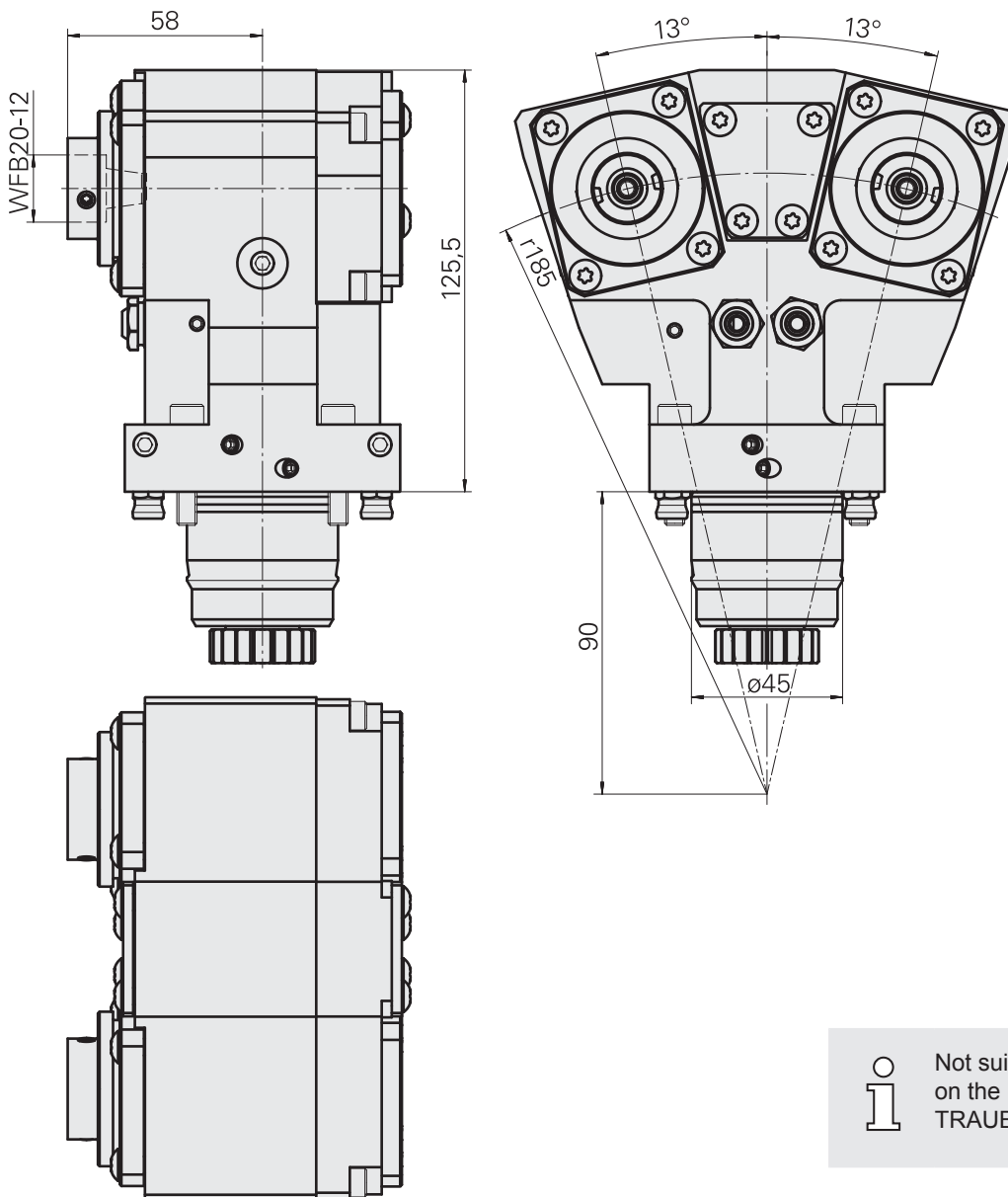
[W980009en](#)

**i** Not suitable for machining on the main spindle of the TRAUB TNL18 and TNL32.

\* This article is included

## Milling unit

<b>Shank</b>	Compact shank 45
<b>Drive</b>	Spur gear (18 Teeth)
<b>Mounting</b>	WFB 20-12
<b>Cooling</b>	external, $p_{max}$ 80 bar
<b>Speed ratio</b>	3:1 (3)
<b>Direction</b>	opposite to drive direction
<b>reversible 180°</b>	no
<b>X / Y / Z</b>	95 (3.74) / - / -37 (-1.46) mm (")

### Matching accessories

Conical ring*	314739
Cap screw*	314740
Tube*	W9990658
WFB with shrink-fit mounting	904006
WFB with Weldon mounting	904007
WFB with collet mounting	904008
WFB with mill arbor mounting	904009
WFB hydr. expansion mounting	904010
WFB for Turning tool holder	904011
WFB for tap chuck	WZ9990.9613F
WFB miscellaneous mountings	WZ9990.9612F
Grub screw*	326171

### Other documents

Product note	<a href="#">W980009en</a>
--------------	---------------------------

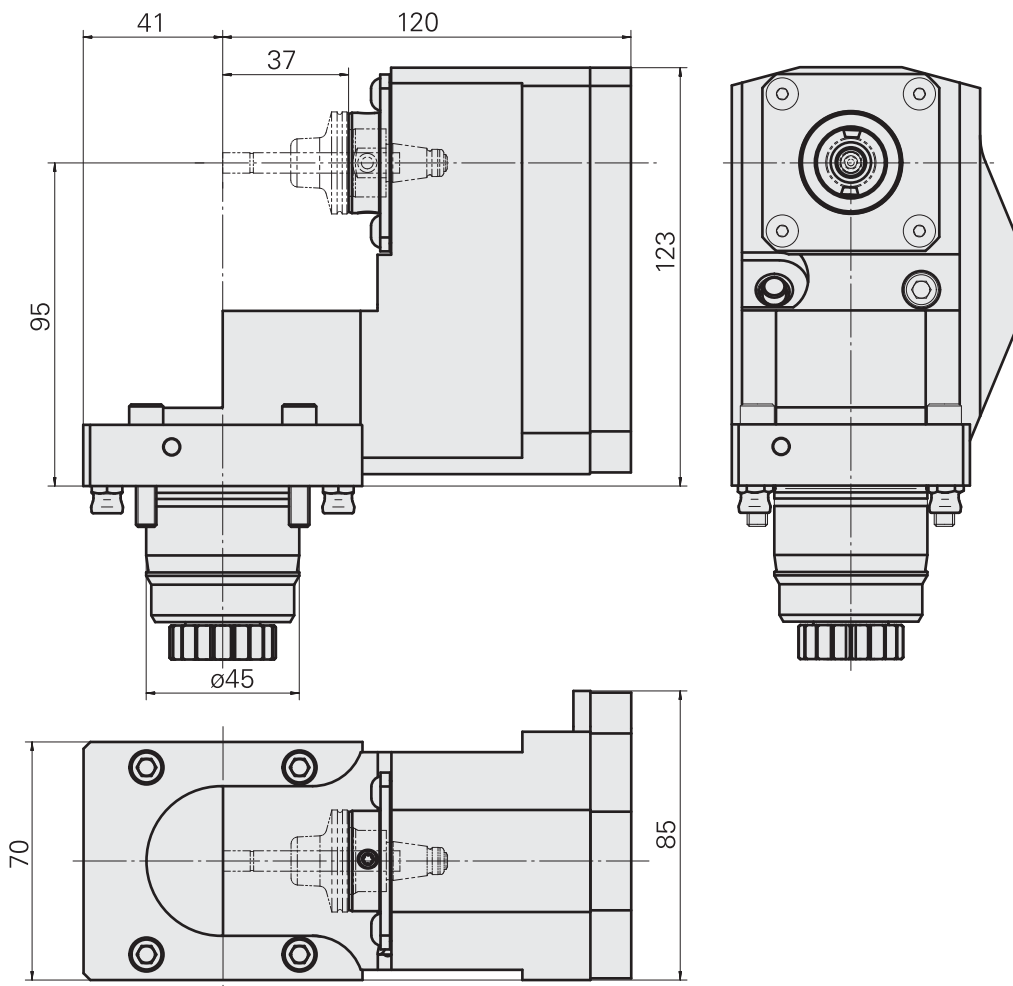

\* This article is included

## Thread whirling unit

<b>Shank</b>	Compact shank 45
<b>Drive</b>	Spur gear (18 Teeth)
<b>Mounting</b>	–
<b>Cooling</b>	external, $p_{max}$ 80 bar
<b>Speed ratio</b>	1.97:1 (1.97)
<b>Direction</b>	opposite to drive direction
<b>reversible 180°</b>	no
<b>X / Y / Z</b>	80 (3.15) / – / -4.5 (-0.18) mm (")

### Matching cutting tools

Drawing 900884

### Matching accessories

Conical ring\* 314739  
 Cap screw\* 314740  
 Tube\* W9990658

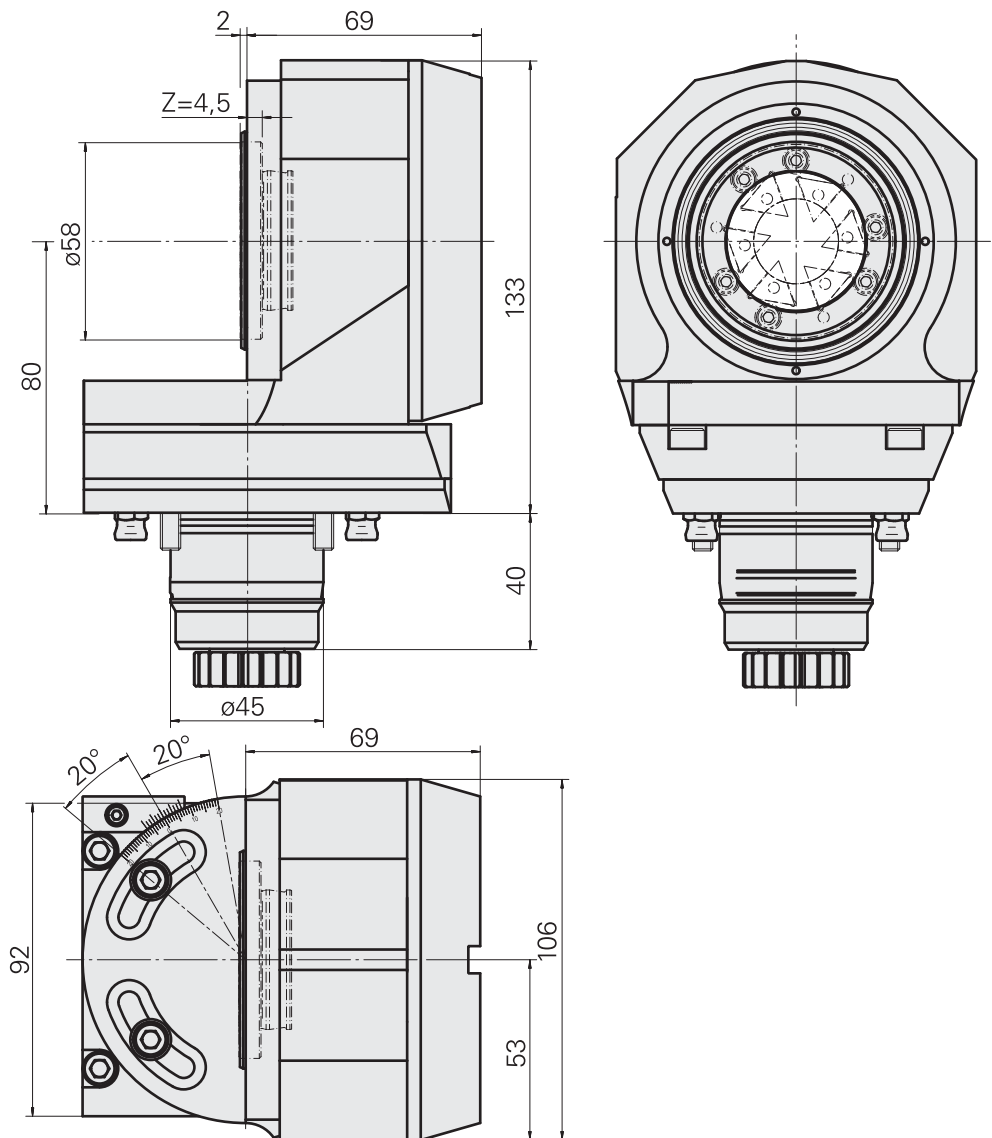

 The whirl head is not included.

\* This article is included

## Broaching/ Slotting unit

<b>Shank</b>	Compact shank 45
<b>Drive</b>	Spur gear (18 Teeth)
<b>Mounting</b>	WFB 20-12
<b>Cooling</b>	external, $p_{\max}$ 80 bar
<b>Speed ratio</b>	1:1 (1)
<b>Direction</b>	opposite to drive direction
<b>reversible 180°</b>	no
<b>X / Y / Z</b>	95 (3.74) / - / -37 (-1.46) mm (")

### Matching accessories

Conical ring	471060.0601
Bush	471112.06
Tube*	818617
Tube*	W9990658
Adaptor	W9990288
Grub screw*	326171

### Other documents

Product note	W980009en
--------------	-----------

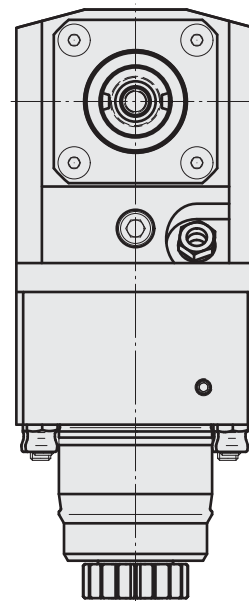
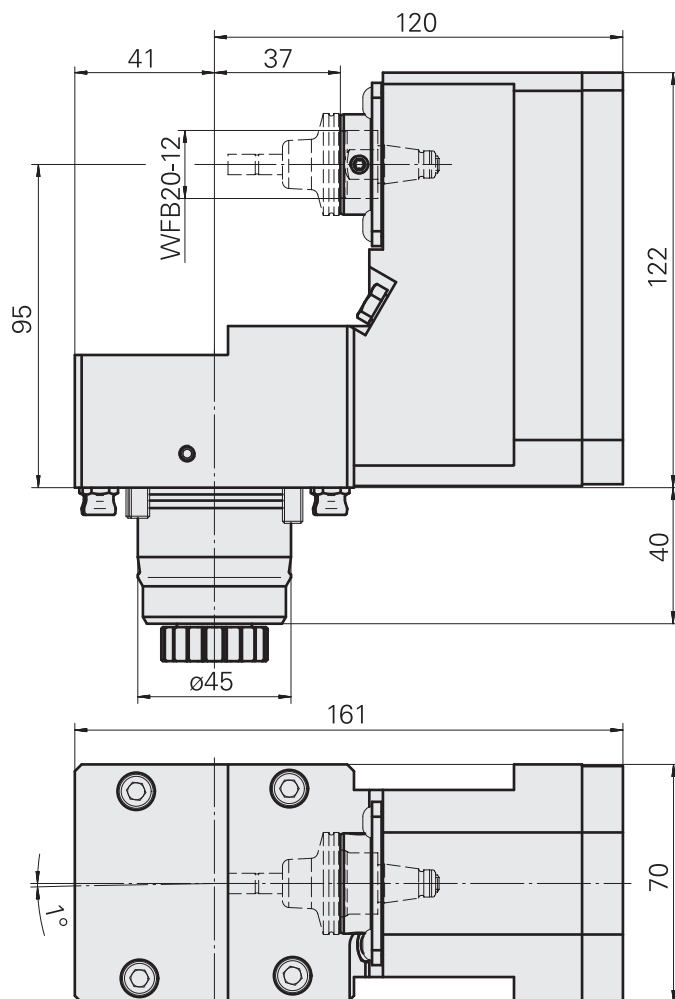

**i** The reference point for the tool is the intersection of the shank axis with the tool axis.

\* This article is included

## Polygon turning unit

<b>Shank</b>	Compact shank 45
<b>Drive</b>	Spur gear (18 Teeth)
<b>Mounting</b>	WFK 20-12
<b>Cooling</b>	external, $p_{\max}$ 80 bar
<b>Speed ratio</b>	3:1 (3)
<b>Direction</b>	opposite to drive direction
<b>reversible 180°</b>	no
<b>X / Y / Z</b>	85 (3.35) / - / -13.5 (-0.53) mm (")

### Matching accessories

Multiple swivel joint	319562
Tube	W9990658
WFK with mill arbor mounting	WZ9990.9611F

### Other documents

Product note	<a href="#">W980009en</a>
--------------	---------------------------

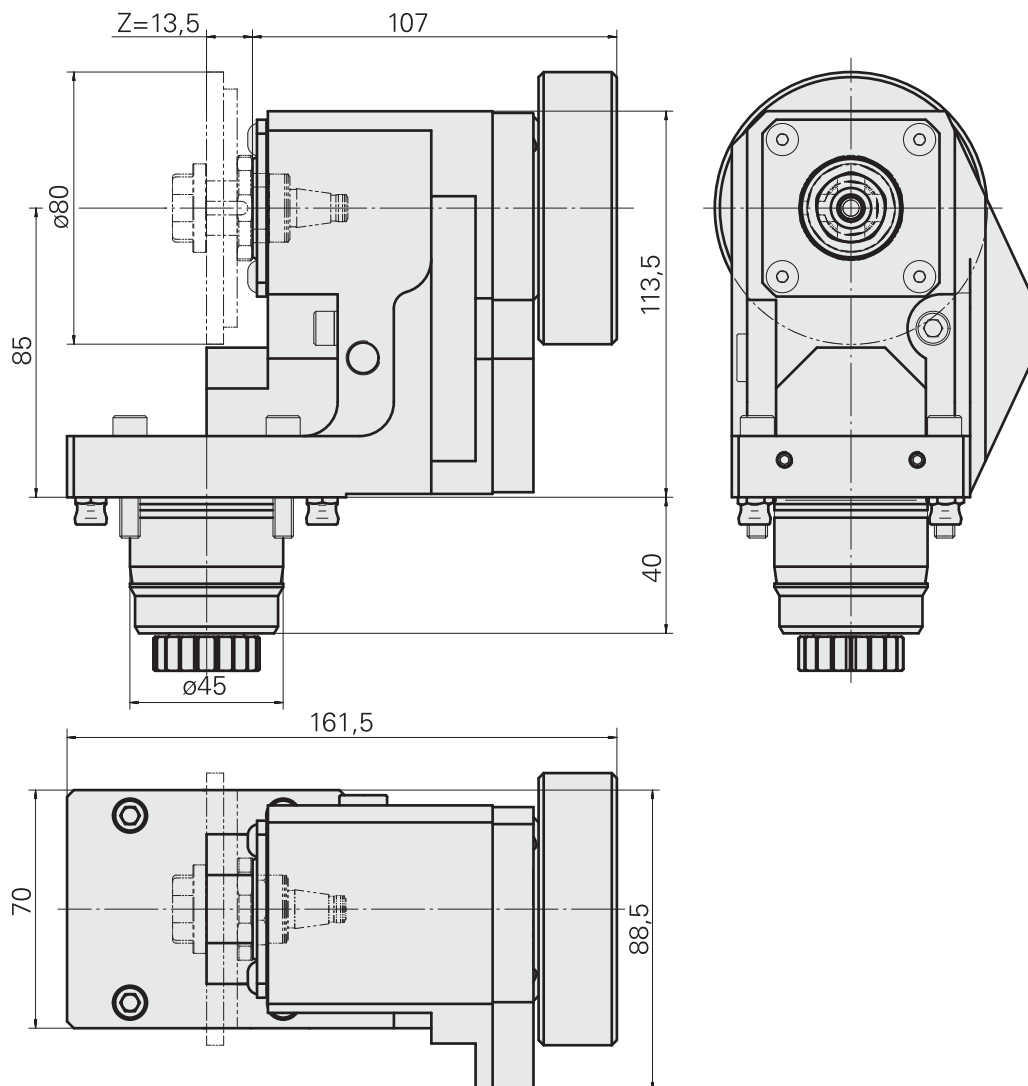

## Milling unit, angle-adjustable

<b>Shank</b>	Compact shank 45
<b>Drive</b>	Spur gear (18 Teeth)
<b>Mounting</b>	WFB 20-12
<b>Cooling</b>	external, $p_{\max}$ 80 bar
<b>Speed ratio</b>	1.03:1 (1.0267)
<b>Direction</b>	opposite to drive direction
<b>X / Y / Z</b>	81 (3.19) / 17 (0.67) / – mm (")

### Matching accessories

Multiple swivel joint*	314431
Conical ring*	314739
Cap screw*	314740
Tube*	W9990658
WFB with shrink-fit mounting	904006
WFB with Weldon mounting	904007
WFB with collet mounting	904008
WFB with mill arbor mounting	904009
WFB hydr. expansion mounting	904010
WFB for Turning tool holder	904011
WFB for tap chuck	WZ9990.9613F
WFB miscellaneous mountings	WZ9990.9612F
Grub screw*	326171

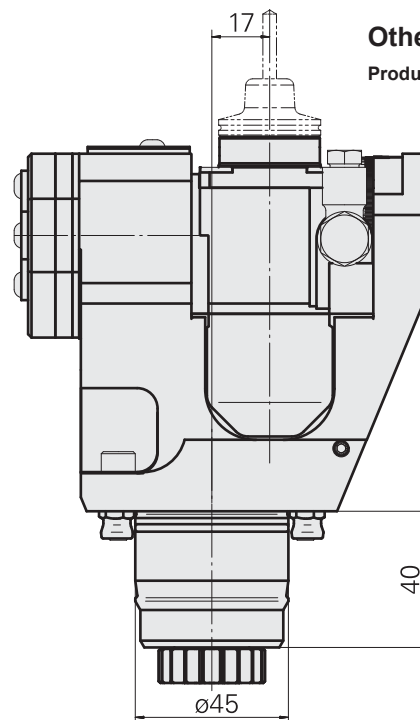
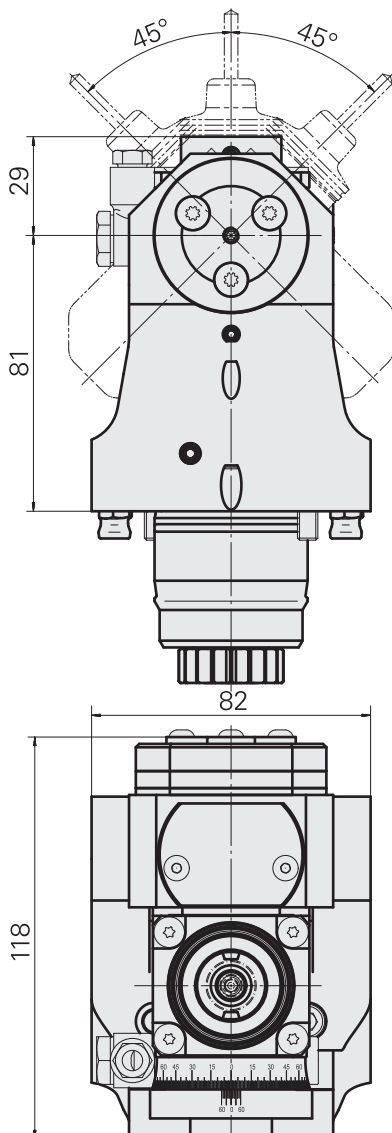

### Other documents

Product note	W9800009en
--------------	------------

\* This article is included

## Milling unit, angle-adjustable

<b>Shank</b>	Compact shank 45
<b>Drive</b>	Spur gear (18 Teeth)
<b>Mounting</b>	WFB 20-12
<b>Cooling</b>	external, $p_{max}$ 80 bar
<b>Speed ratio</b>	1.15:1 (1.1499)
<b>Direction</b>	same as drive direction
<b>reversible 180°</b>	no
<b>X / Y / Z</b>	90 mm (3.54 ") / - / 21.5 (0.85) mm (")

### Matching accessories

Multiple swivel joint*	314431
Conical ring*	314739
Cap screw*	314740
Tube*	W9990658
WFB with shrink-fit mounting	904006
WFB with Weldon mounting	904007
WFB with collet mounting	904008
WFB with mill arbor mounting	904009
WFB hydr. expansion mounting	904010
WFB for Turning tool holder	904011
WFB for tap chuck	WZ9990.9613F
WFB miscellaneous mountings	WZ9990.9612F
Grub screw*	326171

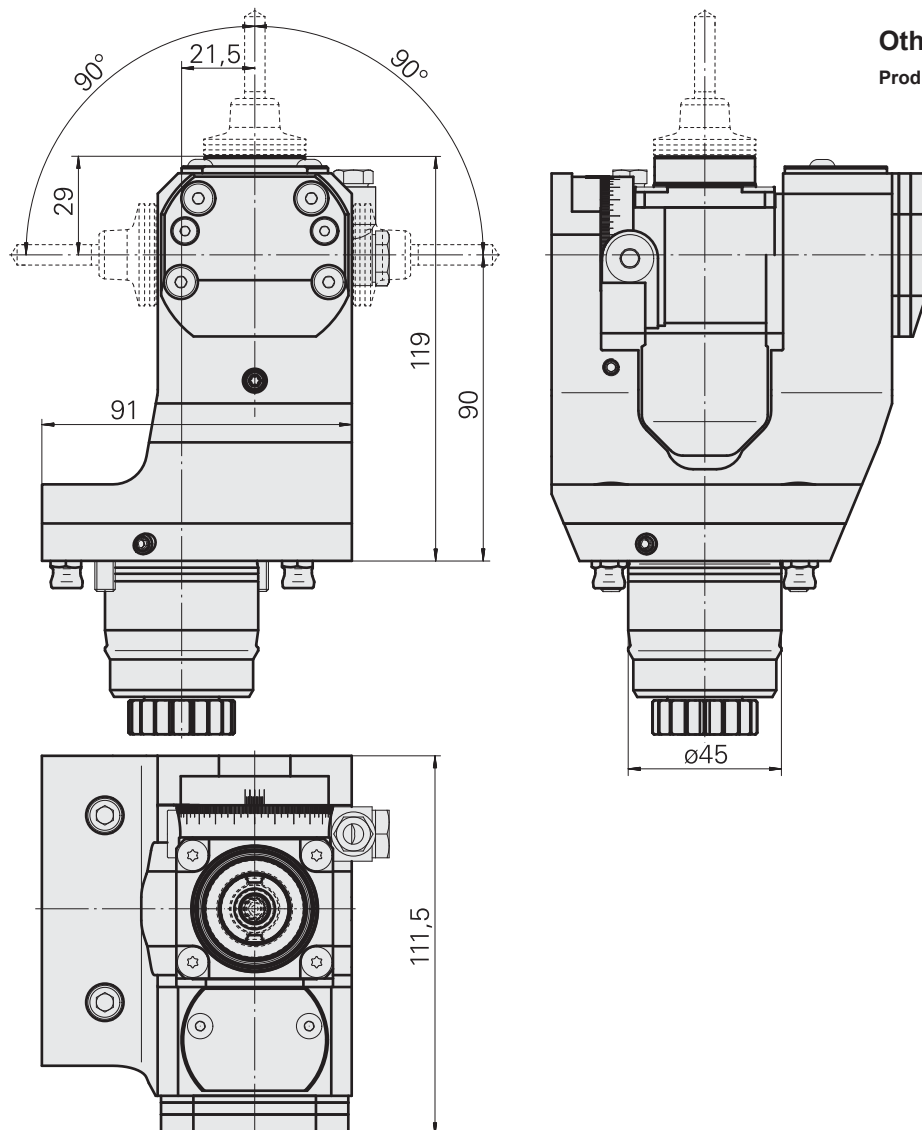

### Other documents

Product note	W9800009en
--------------	------------

\* This article is included



**Tool Holder Fix  
Rear End Machining Unit**

**TRAUB TNL 18P**

**TRAUB TNL 18-7**

**TRAUB TNL 18-7B**

## Porte-foret

<b>Queue</b>	Queue 36
<b>Attachement</b>	ER 16
<b>Arrosage</b>	extérieur, en option central, $p_{max}$ 80 bar, AC optionnel 160 bar
<b>Réversible 180°</b>	non
<b>X / Y / Z</b>	- / - / 71 mm

### Accessoires correspondants

Pince de serrage	901930.1---
Pince de serrage	W99903--
Pince de taraudage	3230--
Pince de taraudage	WZ9990.9506F
Pince de serrage	W999065-
Pince de serrage, scellée	W999083-
Ecrou de serrage*	901939.6161
Ecrou de serrage	W9990347
Rondelle d'étanchéité	W999036-
joint tournant	W9990140
Manchon visse*	470521.06
Joint*	471081.06
Ecrou-a-chapeau*	471161.06
Tube*	818617
Clé	490219.2161

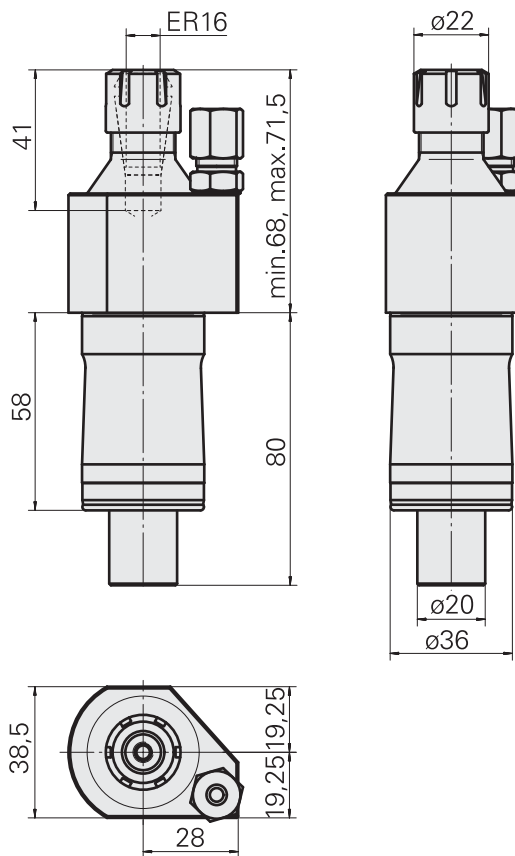

\* Cet article est inclus

## Porte-foret

<b>Queue</b>	Queue 36
<b>Attachement</b>	ER 16
<b>Arrosage</b>	extérieur, en option central, $p_{max}$ 80 bar, AC optionnel 160 bar
<b>Réversible 180°</b>	non
<b>X / Y / Z</b>	- / - / 101 mm

### Accessoires correspondants

Pince de serrage	901930.1---
Pince de serrage	W99903--
Pince de taraudage	3230--
Pince de taraudage	WZ9990.9506F
Pince de serrage	W999065-
Pince de serrage, scellée	W999083-
Ecrou de serrage*	901939.6161
Ecrou de serrage	W9990347
Rondelle d'étanchéité	W999036-
joint tournant	W9990140
Manchon visse*	470521.06
Joint*	471081.06
Ecrou-a-chapeau*	471161.06
Tube*	818617
Clé	490219.2161

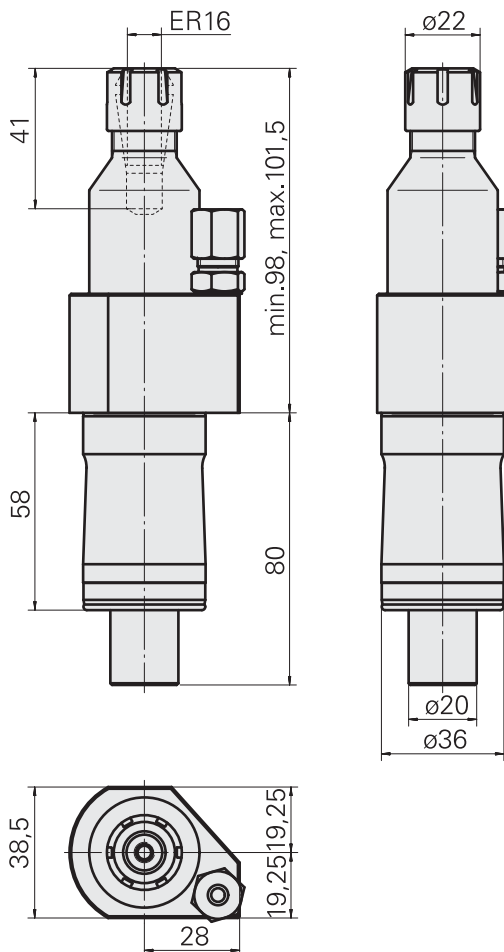

\* Cet article est inclus

## Porte-foret

<b>Queue</b>	Queue 36
<b>Attachement</b>	D20
<b>Arrosage</b>	extérieur, en option central, $p_{max}$ 80 bar, AC optionnel 160 bar
<b>Réversible 180°</b>	non
<b>X / Y / Z</b>	- / - / 65 mm

### Accessoires correspondants

<b>Douille</b>	W68510.04--
<b>joint tournant</b>	W9990140
<b>Manchon visse*</b>	470521.06
<b>Joint*</b>	471081.06
<b>Ecrou-a-chapeau*</b>	471161.06
<b>Tube*</b>	818617

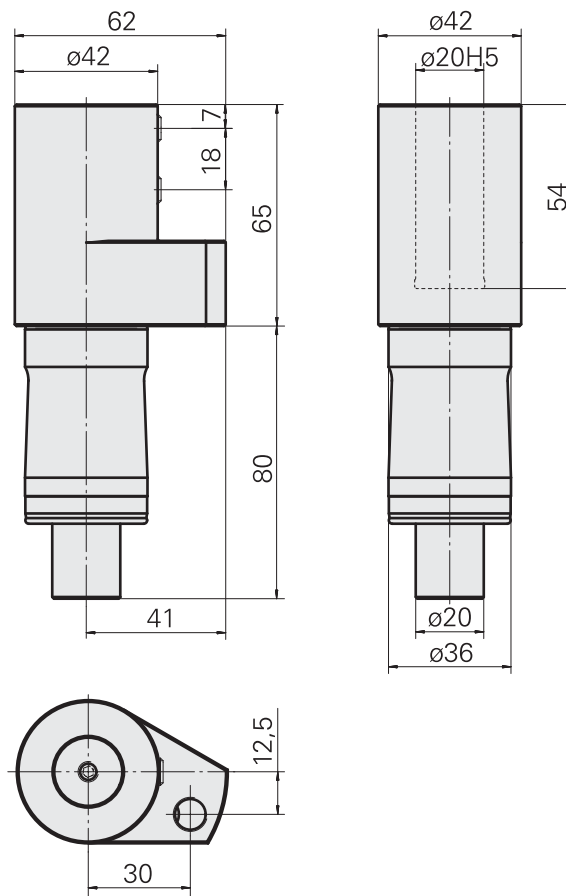

\* Cet article est inclus

**Porte-outil de base, double**

<b>Queue</b>	Queue 36
<b>Attachement</b>	D25
<b>Arrosage</b>	central et extérieur, $p_{max}$ 80 bar, AC optionnel 160 bar
<b>X / Y / Z</b>	35 / 0 + 33 / – mm

**Modules correspondants**

<b>Attachement</b>	W9990556
<b>Attachement</b>	W9990557
<b>Attachement</b>	W9990558

**Accessoires correspondants**

<b>joint tournant</b>	W9990140
<b>Manchon visse*</b>	470521.06
<b>Joint*</b>	471081.06
<b>Ecrou-a-chapeau*</b>	471161.06
<b>Tube*</b>	W9990658

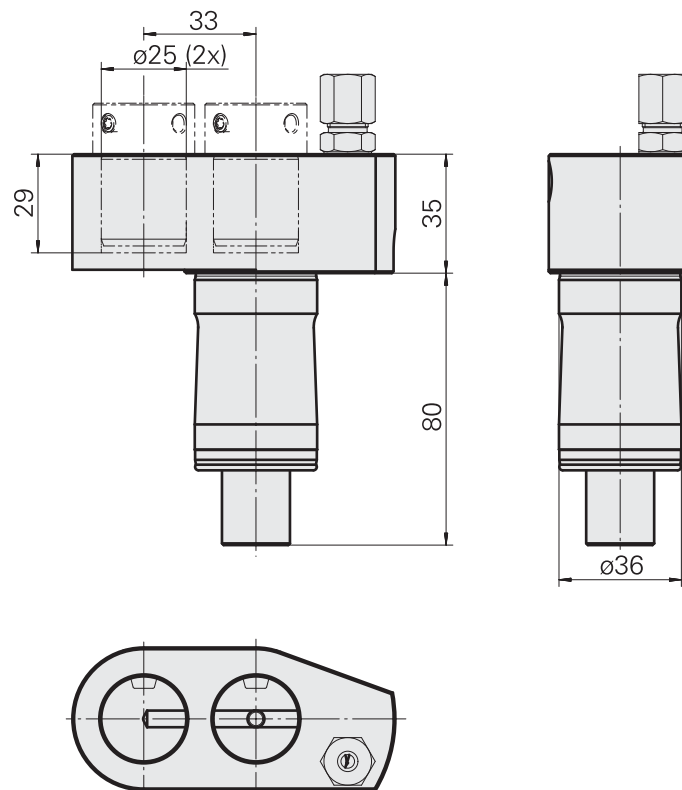

\* Cet article est inclus

## Attachement

Queue	–
Attachement	ER 16
Arrosage	central, $p_{\max}$ 80 bar
X / Y / Z	50 / – / – mm

### PO de base correspondants

Porte-outil de base	W7140009
Porte-outil de base	W7140006

### Accessoires correspondants

Pince de serrage	W99903--
Pince de serrage	901930.1---
Pince de taraudage	WZ9990.9506F
Pince de taraudage	3230--
Pince de serrage	W999065-
Ecrou de serrage*	901939.5161
Ecrou de serrage	326691
Rondelle d'étanchéité	W999036-
Clé	490219.3161

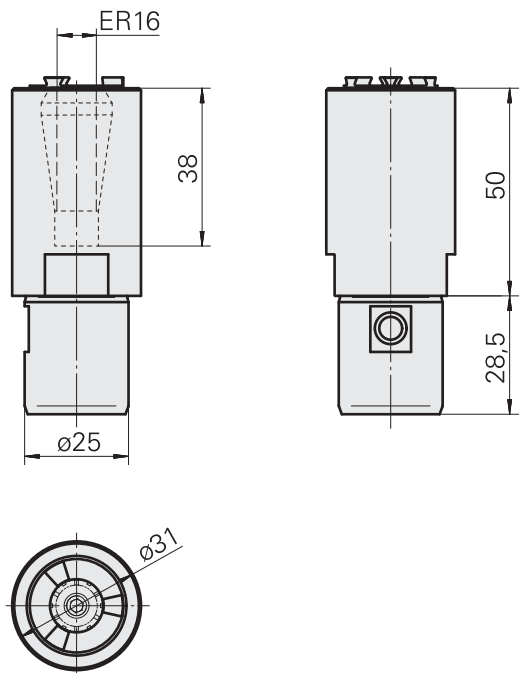

\* Cet article est inclus

## Attachement

Queue	–
Attachement	D16
Arrosage	central, $p_{\max}$ 80 bar
X / Y / Z	45 / – / – mm

### PO de base correspondants

Porte-outil de base	W7140009
Porte-outil de base	W7140006

### Accessoires correspondants

Douille	W67511.04--
---------	-------------

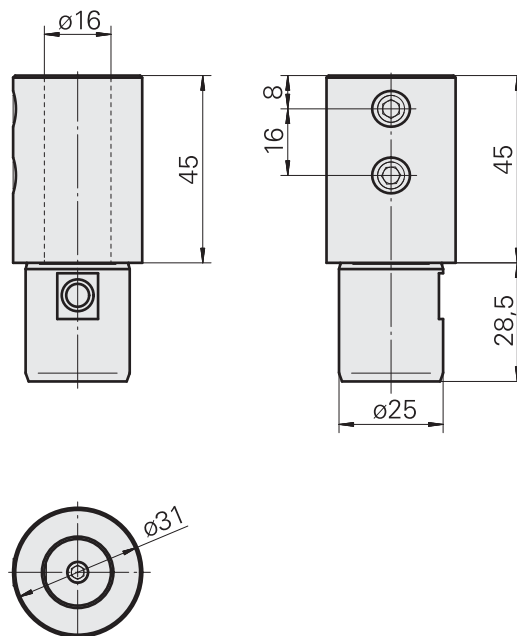

## Attachement

Queue	–
Attachement	WFB 20-12
Arrosage	central, $p_{\max}$ 80 bar
Direction	idem sens d'entraînement
X / Y / Z	15 / – / – mm

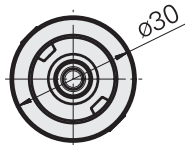
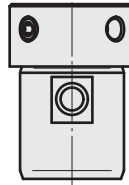
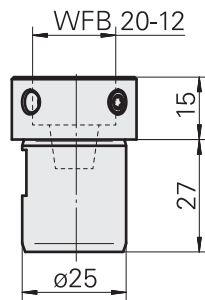

### PO de base correspondants

Porte-outil de base	W7140009
Porte-outil de base	W7140006

### Accessoires correspondants

Goupille filetée*	326171
WFB avec mandrin de frettage	904006
WFB avec attachement Weldon	904007
WFB avec att. pince de serrage	904008
WFB avec att. porte fraise	904009
WFB avec att. hydroexpansible	904010
WFB pour PO de tournage	904011
WFB pour Horn S-Mini	904012
WFB pour PO de tournage	904013
WFB pour Mandrin de filetage	WZ9990.9613F
WFB autres attachements	WZ9990.9612F

### D'autres documents

Note du produit	<a href="#">W9800009fr</a>
-----------------	----------------------------

\* Cet article est inclus





## Porte-outil de base

Queue	Queue 36
Attachement	D28
Arrosage	extérieur, $p_{\max}$ 10 bar
X / Y / Z	- / - / 54 mm

### Accessoires correspondants

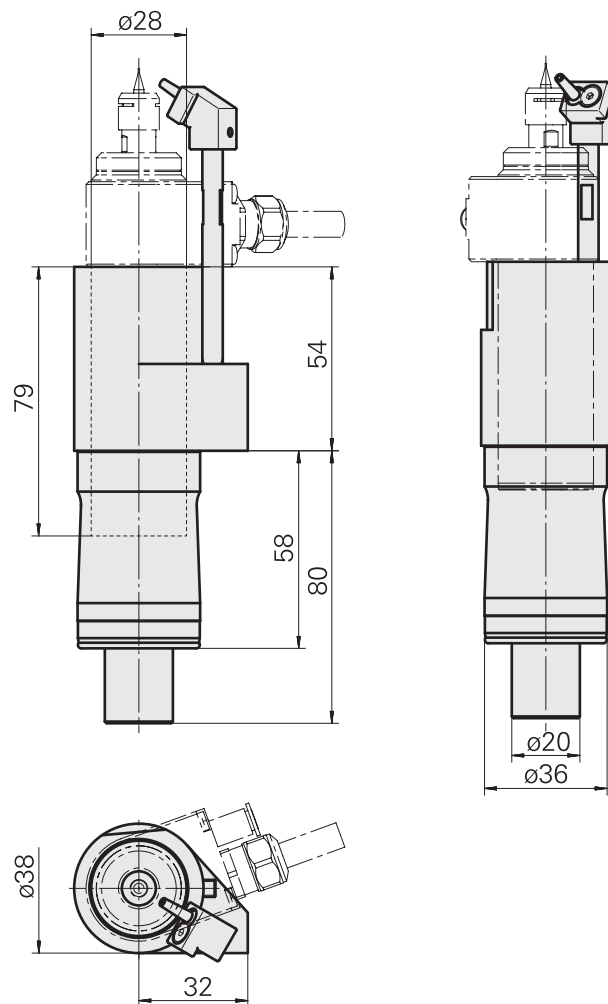
Tube*	904035
Cale*	904036
Gicleur*	904037
Vis à tête noyée*	322037
Cde d'entraînement de broche	326548



 La machine doit disposer de l'option "prédisposé pour broche haute fréquence"!

\* Cet article est inclus

## Porte-outil de base

<b>Queue</b>	Queue 36
<b>Attachement</b>	Hydroexpansible D12
<b>Arrosage</b>	central et extérieur, $p_{max}$ 80 bar, AC optionnel 160 bar
<b>Réversible 180°</b>	non
<b>X / Y / Z</b>	85 / - / - mm

### Accessoires correspondants

<b>Douille*</b>	W9990911
<b>joint tournant</b>	W9990140
<b>Manchon visse*</b>	470521.06
<b>Joint*</b>	471081.06
<b>Ecrou-a-chapeau*</b>	471161.06
<b>Tube*</b>	W9990658

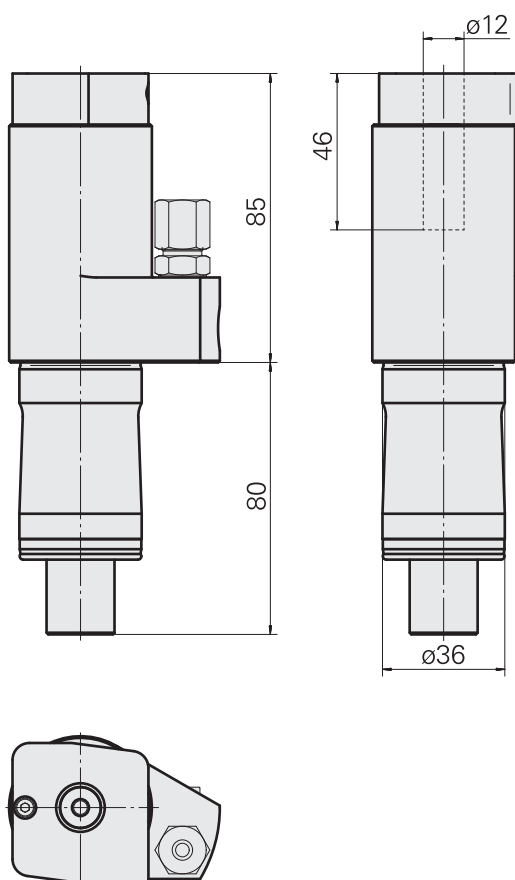

\* Cet article est inclus

## Porte-outil de base

<b>Queue</b>	Queue 36
<b>Attachement</b>	WFB 20-12
<b>Arrosage</b>	extérieur, en option central, $p_{max}$ 80 bar, AC optionnel 160 bar
<b>Réversible 180°</b>	non
<b>X / Y / Z</b>	- / - / 50 mm

### Accessoires correspondants

joint tournant	W9990140
Manchon visse*	470521.06
Joint*	471081.06
Ecrou-a-chapeau*	471161.06
Tube*	818617
WFB avec mandrin de frettage	904006
WFB avec attachement Weldon	904007
WFB avec att. pince de serrage	904008
WFB avec att. porte fraise	904009
WFB avec att. hydroexpansible	904010
WFB pour PO de tournage	904011
WFB pour Horn S-Mini	904012
WFB pour PO de tournage	904013
WFB pour Mandrin de filetage	WZ9990.9613F
WFB autres attachements	WZ9990.9612F
Goupille fileté*	326171
Vis	900783

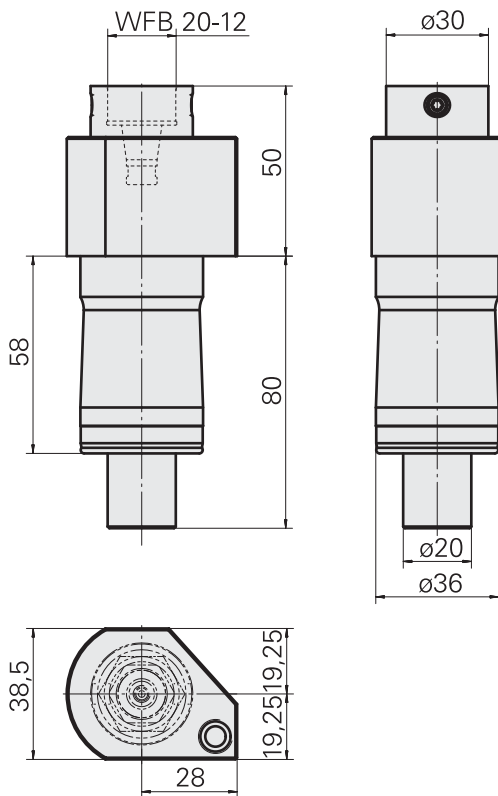

### D'autres documents

Note du produit	<a href="#">W9800009fr</a>
-----------------	----------------------------

\* Cet article est inclus

## Porte-outil de base, réglable en XY

<b>Queue</b>	Queue 36
<b>Attachement</b>	WFB 20-12
<b>Arrosage</b>	extérieur, en option central, $p_{max}$ 80 bar, AC optionnel 160 bar
<b>Réversible 180°</b>	non
<b>X / Y / Z</b>	- / - / 50 mm

### Accessoires correspondants

joint tournant	W9990140
Manchon visse*	470521.06
Joint*	471081.06
Ecrou-a-chapeau*	471161.06
Tube*	818617
WFB avec mandrin de frettage	904006
WFB avec attachement Weldon	904007
WFB avec att. pince de serrage	904008
WFB avec att. porte fraise	904009
WFB avec att. hydroexpansible	904010
WFB pour PO de tournage	904011
WFB pour Horn S-Mini	904012
WFB pour PO de tournage	904013
WFB pour Mandrin de filetage	WZ9990.9613F
WFB autres attachements	WZ9990.9612F
Goupille fileté*	326171

### D'autres documents

Note du produit	<a href="#">W9800009fr</a>
-----------------	----------------------------

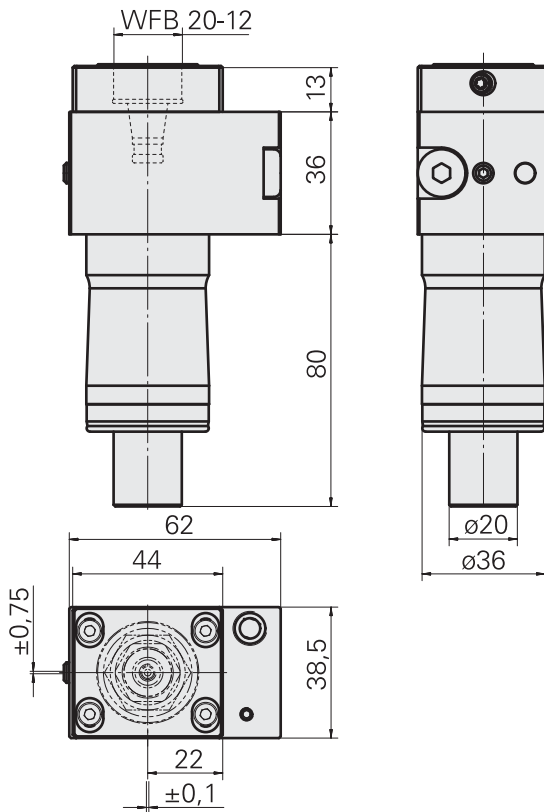

\* Cet article est inclus

## Porte-outil de base

Queue	Queue 36
Attachement	INDEX TRAUB CAPTO C3
Arrosage	central et extérieur, $p_{\max}$ 120 bar
X / Y / Z	60 / - / - mm

### Accessoires correspondants

Inserts chgt rapide	WZ9990.3000F
---------------------	--------------

### D'autres documents

Note du produit	W9800011fr
-----------------	------------

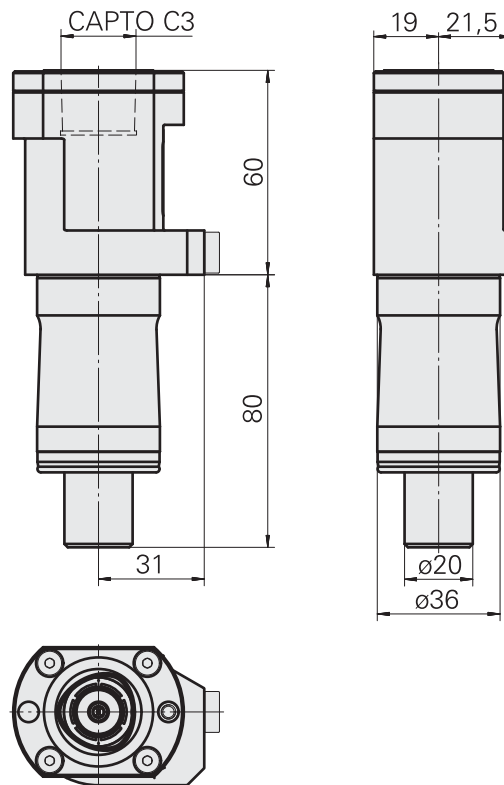

## Obturateur, Acier

Queue	Queue 36
Attachement	-
Arrosage	-
X / Y / Z	- / - / 40 mm

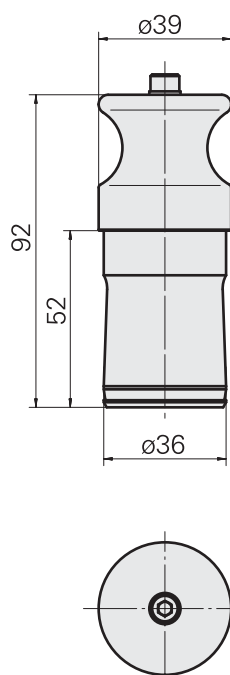

**Live Tool Holder**

**Rear End Machining Unit**

**TRAUB TNL 18P**

**TRAUB TNL 18-7**

**TRAUB TNL 18-7B**

## Milling unit

<b>Shank</b>	Shank 36
<b>Drive</b>	Spur gear (26 Teeth)
<b>Mounting</b>	ER 16
<b>Cooling</b>	external, internal optional, $p_{max}$ 80 bar, internal 160 bar optional
<b>Speed ratio</b>	1:1 (1)
<b>Direction</b>	same as drive direction
<b>reversible 180°</b>	no
<b>X / Y / Z</b>	- / - / 80 (3.15) mm (")

## Matching accessories

Clamping collet	W99903--
Clamping collet	901930.1--
tapping tool collet	3230--
tapping tool collet	WZ9990.9506F
Collet chuck	W999065-
Clamping collet, sealed	W999083-
Clamping nut*	901939.6161
Clamping nut	W9990347
Sealing washer	W999036-
rotary delivery device	W9990140
rotary delivery device	W9990141
Pipe connector*	470521.06
Ring*	471081.06
Spindle nose cap*	471161.06
Tube*	818617
Spanner	490219.2161

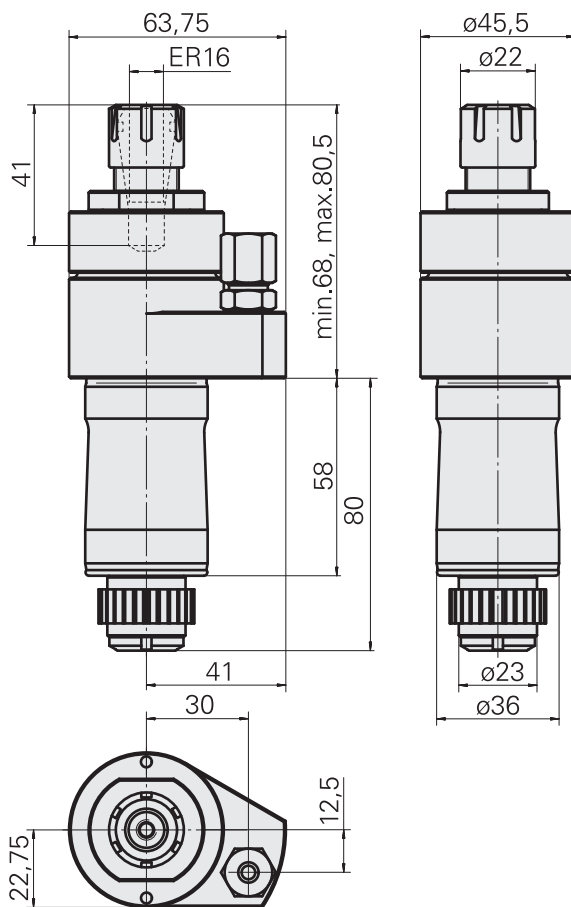

\* This article is included



## Milling unit

<b>Shank</b>	Shank 36
<b>Drive</b>	Spur gear (26 Teeth)
<b>Mounting</b>	ER 16
<b>Cooling</b>	external, internal optional, $p_{max}$ 80 bar, internal 160 bar optional
<b>Speed ratio</b>	1:1 (1)
<b>Direction</b>	same as drive direction
<b>reversible 180°</b>	no
<b>X / Y / Z</b>	- / - / 103 (46) mm (")

## Matching accessories

Clamping collet	W99903--
Clamping collet	901930.1--
tapping tool collet	3230--
tapping tool collet	WZ9990.9506F
Collet chuck	W999065-
Clamping collet, sealed	W999083-
Clamping nut*	901939.6161
Clamping nut	W9990347
Sealing washer	W999036-
rotary delivery device	W9990140
rotary delivery device	W9990141
Pipe connector*	470521.06
Ring*	471081.06
Spindle nose cap*	471161.06
Tube*	818617
Spanner	490219.2161

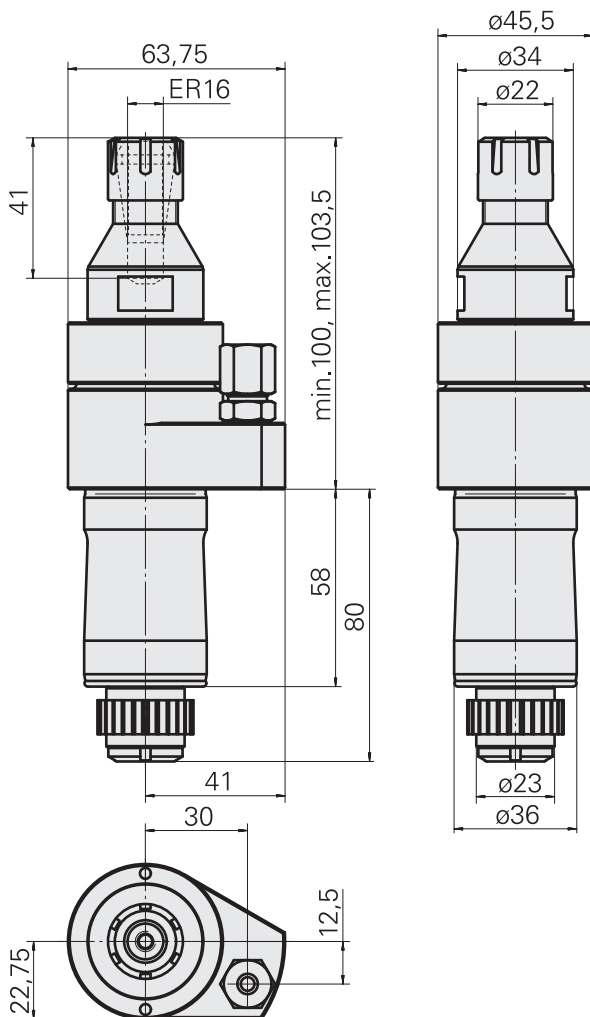

\* This article is included

## Milling unit

<b>Shank</b>	Shank 36
<b>Drive</b>	Spur gear (26 Teeth)
<b>Mounting</b>	WFB 20-12
<b>Cooling</b>	external, internal optional, $p_{max}$ 80 bar, internal 160 bar optional
<b>Speed ratio</b>	1:1 (1)
<b>Direction</b>	same as drive direction
<b>reversible 180°</b>	no
<b>X / Y / Z</b>	- / - / 50 (1.97) mm (")

## Matching accessories

rotary delivery device	W9990140
rotary delivery device	W9990141
Pipe connector*	470521.06
Ring*	471081.06
Spindle nose cap*	471161.06
Tube*	818617
WFB with shrink-fit mounting	904006
WFB with Weldon mounting	904007
WFB with collet mounting	904008
WFB with mill arbor mounting	904009
WFB hydr. expansion mounting	904010
WFB for Turning tool holder	904011
WFB for tap chuck	WZ9990.9613F
WFB miscellaneous mountings	WZ9990.9612F
Grub screw*	326171
Screw	900783

## Other documents

Product note	W9800009en
--------------	------------

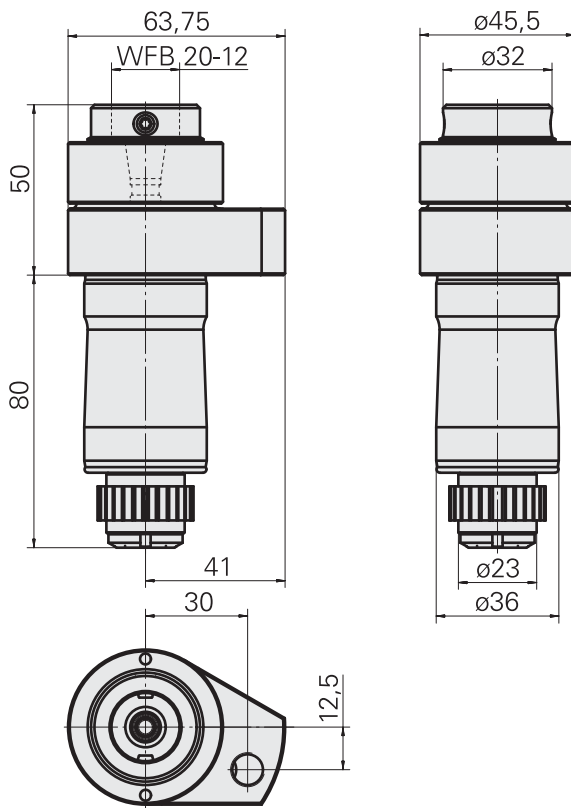

\* This article is included

## Milling unit, double

<b>Shank</b>	Shank 36
<b>Drive</b>	Spur gear (26 Teeth)
<b>Mounting</b>	WFB 20-12
<b>Cooling</b>	external, internal optional, $p_{max}$ 80 bar, internal 160 bar optional
<b>Speed ratio</b>	1:1 (1)
<b>Direction</b>	both directions
<b>reversible 180°</b>	no
<b>X / Y / Z</b>	46 (1.81) / - / 50 (1.97) mm (")

### Matching accessories

rotary delivery device	W9990140
rotary delivery device	W9990141
Pipe connector*	470521.06
Ring*	471081.06
Spindle nose cap*	471161.06
Tube*	818617
WFB with shrink-fit mounting	904006
WFB with Weldon mounting	904007
WFB with collet mounting	904008
WFB with mill arbor mounting	904009
WFB hydr. expansion mounting	904010
WFB for Turning tool holder	904011
WFB for tap chuck	WZ9990.9613F
WFB miscellaneous mountings	WZ9990.9612F
Grub screw*	326171
Screw	900783

### Other documents

Product note	W9800009en
--------------	------------

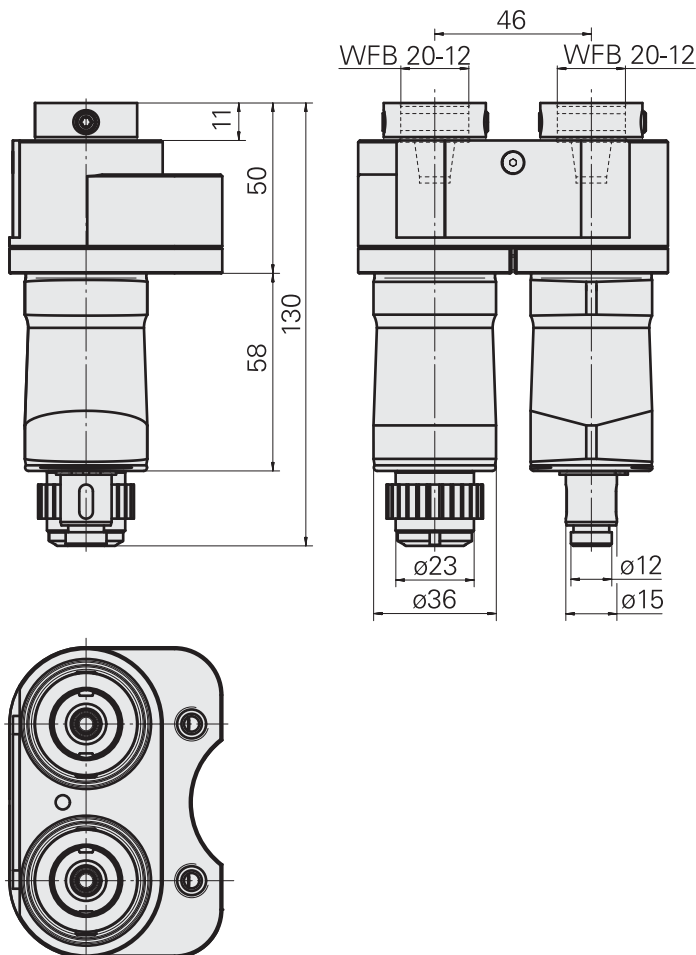

\* This article is included

## Milling unit, double

<b>Shank</b>	Shank 36
<b>Drive</b>	Spur gear (26 Teeth)
<b>Mounting</b>	WFB 20-12
<b>Cooling</b>	external, internal optional, $p_{max}$ 80 bar, internal 160 bar optional
<b>Speed ratio</b>	1:1 (1)
<b>Direction</b>	both directions
<b>reversible 180°</b>	no
<b>X / Y / Z</b>	- / 40 (1.57) / 70 (2.76) mm (")

### Matching accessories

Pipe connector*	470521.06
Ring*	471081.06
Spindle nose cap*	471161.06
Tube*	818617
WFB with shrink-fit mounting	904006
WFB with Weldon mounting	904007
WFB with collet mounting	904008
WFB hydr. expansion mounting	904010
WFB for Turning tool holder	904011
WFB for tap chuck	WZ9990.9613F
WFB miscellaneous mountings	WZ9990.9612F
Grub screw*	326171

### Other documents

Product note	W980009en
--------------	-----------

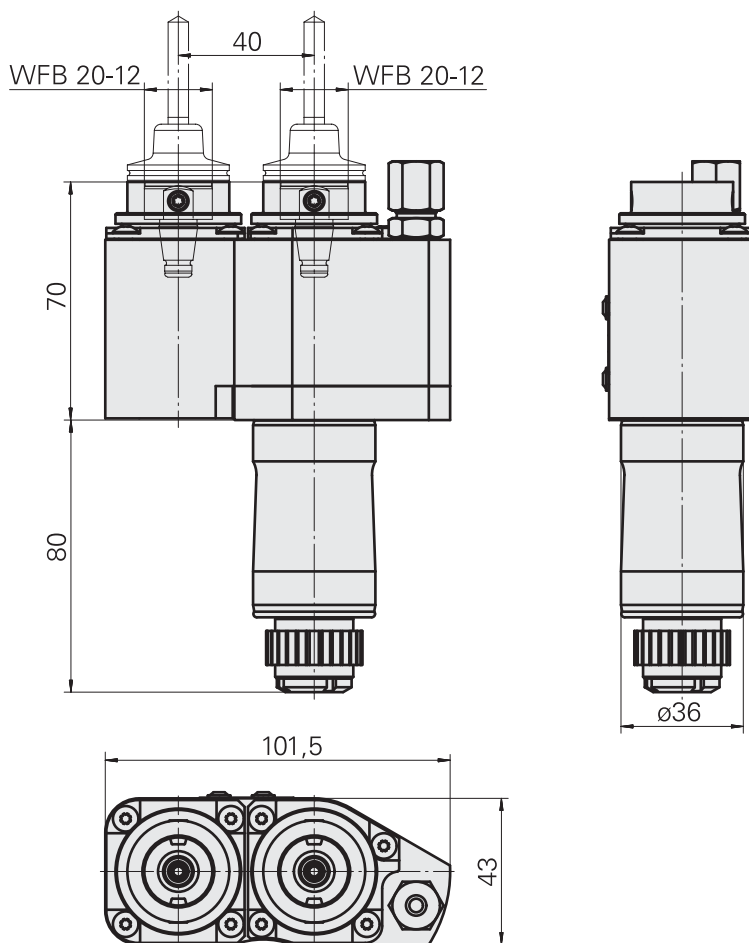

\* This article is included

## Broaching/ Slotting unit

<b>Shank</b>	Shank 36
<b>Drive</b>	Spur gear (26 Teeth)
<b>Mounting</b>	WFB 20-12
<b>Cooling</b>	external, $p_{max}$ 80 bar
<b>Speed ratio</b>	1:1 (1)
<b>Direction</b>	same as drive direction
<b>reversible 180°</b>	no
<b>X / Y / Z</b>	- / - / 51 (21) mm (")

### Matching accessories

Pipe connector*	470521.06
Ring*	471081.06
Spindle nose cap*	471161.06
Tube*	818617
WFB with shrink-fit mounting	904006
WFB with Weldon mounting	904007
WFB with collet mounting	904008
WFB hydr. expansion mounting	904010
WFB for Turning tool holder	904011
WFB for Horn S-Mini	904012
Grub screw*	326171

### Other documents

Product note	<a href="#">W9800009en</a>
--------------	----------------------------

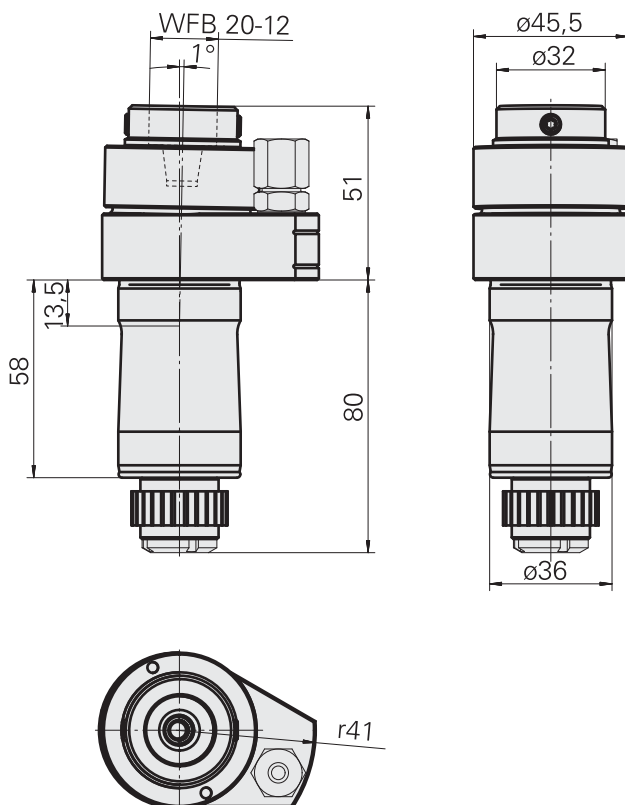

\* This article is included

## Milling unit

<b>Shank</b>	Shank 36
<b>Drive</b>	Spur gear (26 Teeth)
<b>Mounting</b>	WFB 20-12
<b>Cooling</b>	external, $p_{max}$ 40 bar
<b>Speed ratio</b>	1:1 (1)
<b>Direction</b>	opposite to drive direction
<b>reversible 180°</b>	no
<b>X / Y / Z</b>	26 (12) / - / 110 (4.33) mm (")

### Matching accessories

Tube*	904876
Countersunk screw*	322037
WFB with shrink-fit mounting	904006
WFB with Weldon mounting	904007
WFB with collet mounting	904008
WFB with mill arbor mounting	904009
WFB hydr. expansion mounting	904010
WFB for Turning tool holder	904011
WFB for tap chuck	WZ9990.9613F
WFB miscellaneous mountings	WZ9990.9612F
Grub screw*	326171

### Other documents

Product note	<a href="#">W9800009en</a>
--------------	----------------------------

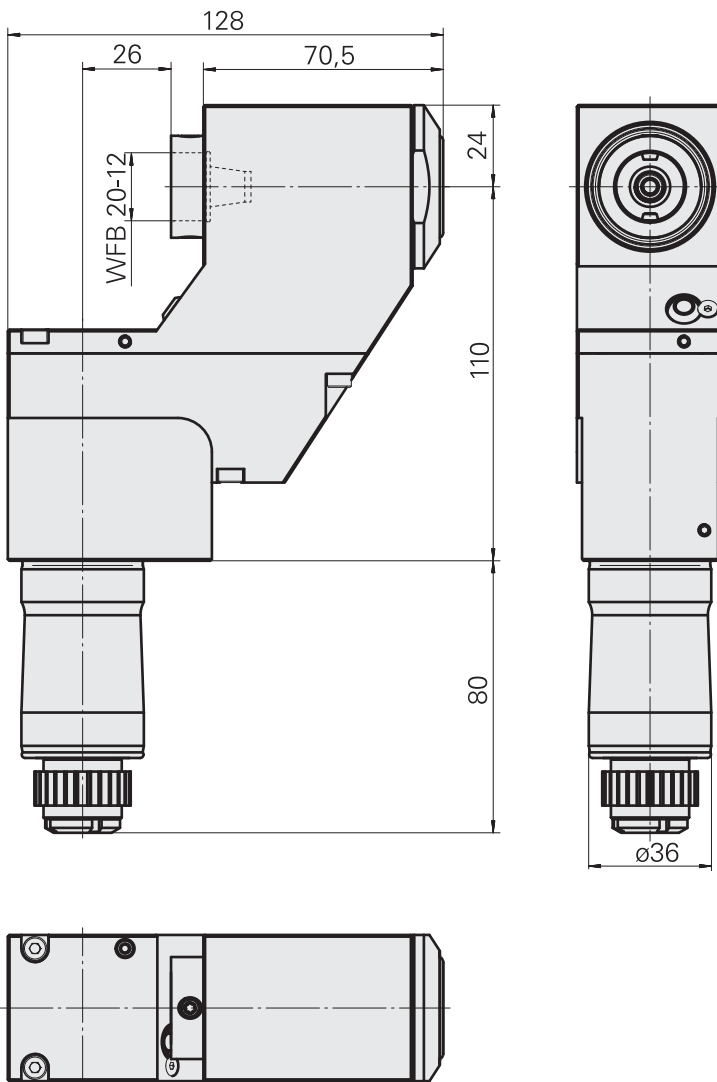

\* This article is included

## Milling unit

<b>Shank</b>	Shank 36
<b>Drive</b>	Spur gear (26 Teeth)
<b>Mounting</b>	WFB 20-12
<b>Cooling</b>	external, $p_{max}$ 40 bar
<b>Speed ratio</b>	1:1 (1)
<b>Direction</b>	opposite to drive direction
<b>reversible 180°</b>	no
<b>X / Y / Z</b>	26 (12) / - / 110 (4.33) mm (")

## Matching accessories

Nozzle*	W67500.3208
Cheese-head screw*	323744
Tube*	W9990559
Cup spring*	419871.0106
WFB with shrink-fit mounting	904006
WFB with Weldon mounting	904007
WFB with collet mounting	904008
WFB with mill arbor mounting	904009
WFB hydr. expansion mounting	904010
WFB for Turning tool holder	904011
WFB for tap chuck	WZ9990.9613F
WFB miscellaneous mountings	WZ9990.9612F
Grub screw*	326171

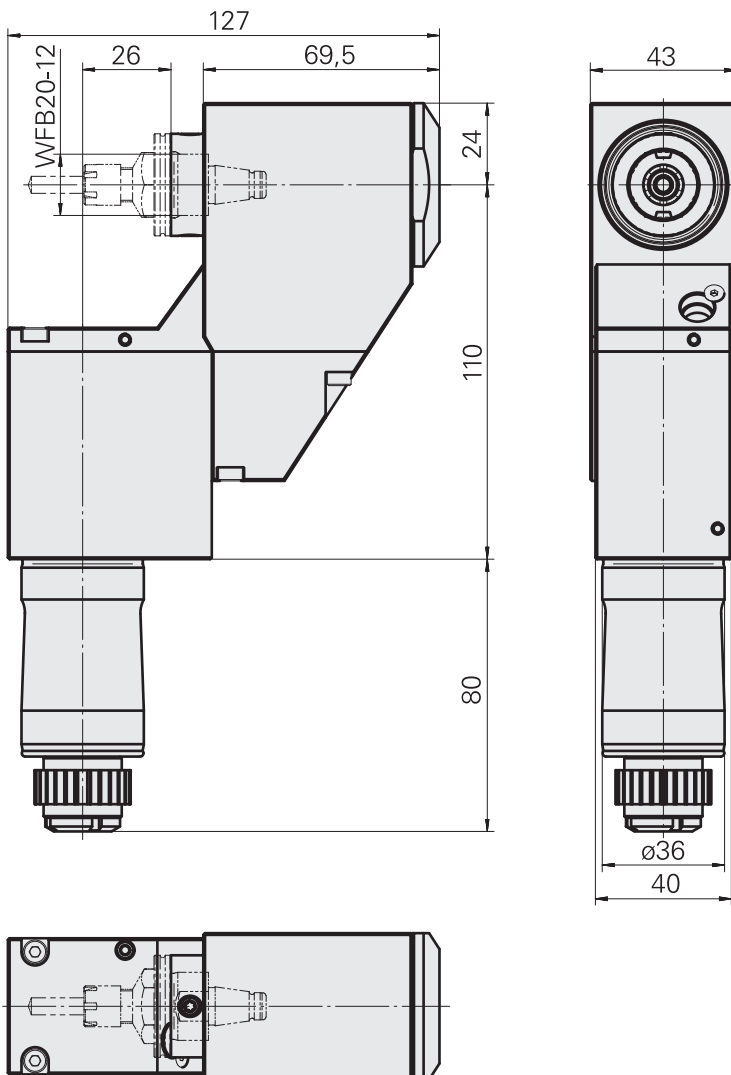

## Other documents

Product note	W9800009en
--------------	------------

\* This article is included

## Milling unit

<b>Shank</b>	Shank 36
<b>Drive</b>	Spur gear (26 Teeth)
<b>Mounting</b>	WFB 20-12
<b>Cooling</b>	external, $p_{max}$ 40 bar
<b>Speed ratio</b>	1:1 (1)
<b>Direction</b>	opposite to drive direction
<b>reversible 180°</b>	no
<b>X / Y / Z</b>	26 (12) / - / 130 (5.12) mm (")

## Matching accessories

Tube*	904876
Countersunk screw*	322037
WFB with shrink-fit mounting	904006
WFB with Weldon mounting	904007
WFB with collet mounting	904008
WFB with mill arbor mounting	904009
WFB hydr. expansion mounting	904010
WFB for Turning tool holder	904011
WFB for tap chuck	WZ9990.9613F
WFB miscellaneous mountings	WZ9990.9612F
Grub screw*	326171

## Other documents

Product note	<a href="#">W9800009en</a>
--------------	----------------------------

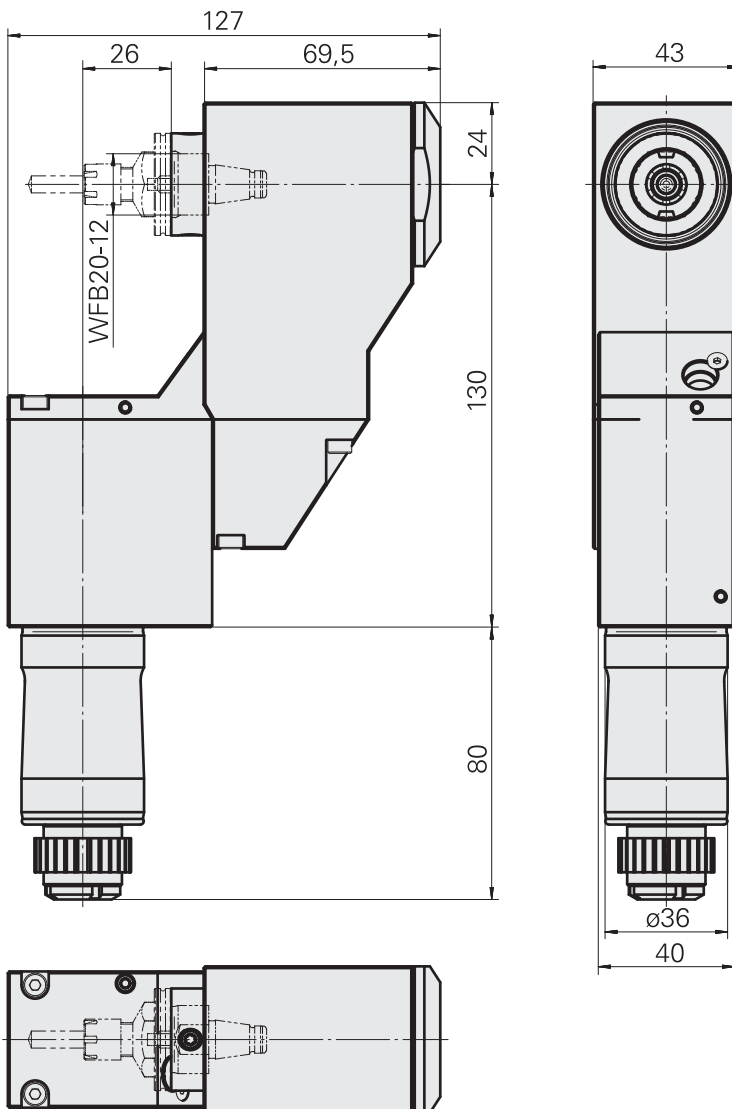

\* This article is included



## Milling unit

<b>Shank</b>	Shank 36
<b>Drive</b>	Spur gear (26 Teeth)
<b>Mounting</b>	WFB 20-12
<b>Cooling</b>	external, $p_{max}$ 40 bar
<b>Speed ratio</b>	2:1 (2)
<b>Direction</b>	opposite to drive direction
<b>reversible 180°</b>	no
<b>X / Y / Z</b>	26 (12) / - / 110 (4.33) mm (")

## Matching accessories

Tube*	904876
Countersunk screw*	322037
WFB with shrink-fit mounting	904006
WFB with Weldon mounting	904007
WFB with collet mounting	904008
WFB with mill arbor mounting	904009
WFB hydr. expansion mounting	904010
WFB for Turning tool holder	904011
WFB for tap chuck	WZ9990.9613F
WFB miscellaneous mountings	WZ9990.9612F
Grub screw*	326171

## Other documents

Product note	<a href="#">W9800009en</a>
--------------	----------------------------

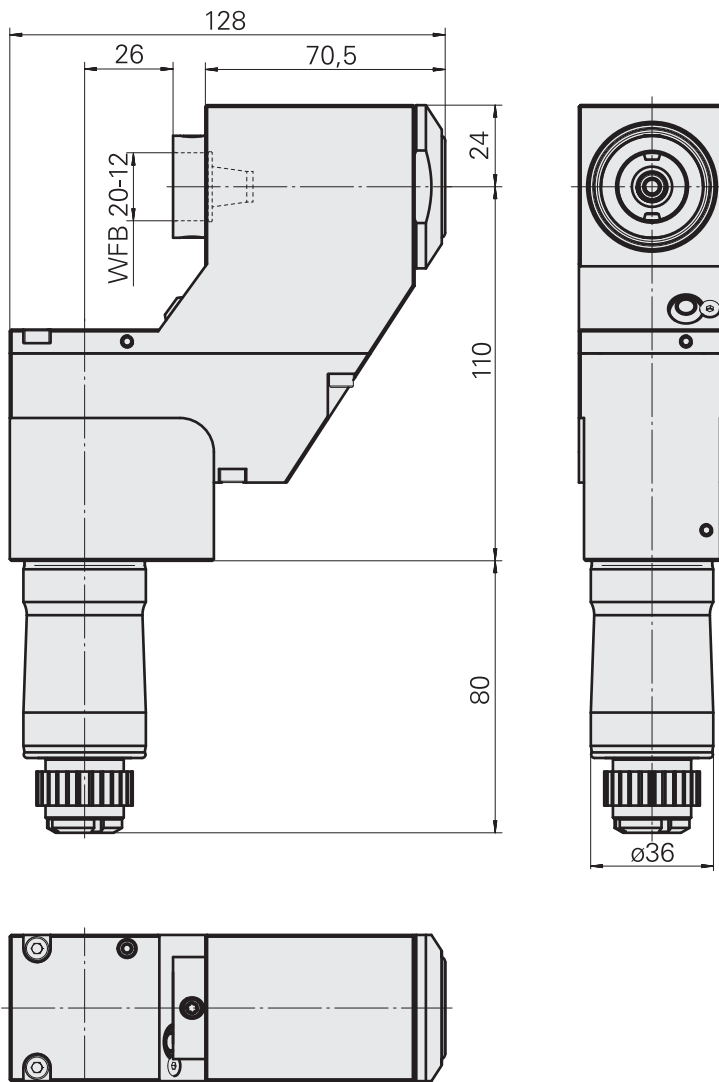

\* This article is included



**Accessories**

**Quick-change inserts**

**WFB20-12**

**Shrink-fit mounting**

## Quick-change inserts WFB20-12

W-T shrink-fit chuck,  $\varnothing 3 \times 51$

### Accessories

Adjusting screw W&F  
326793

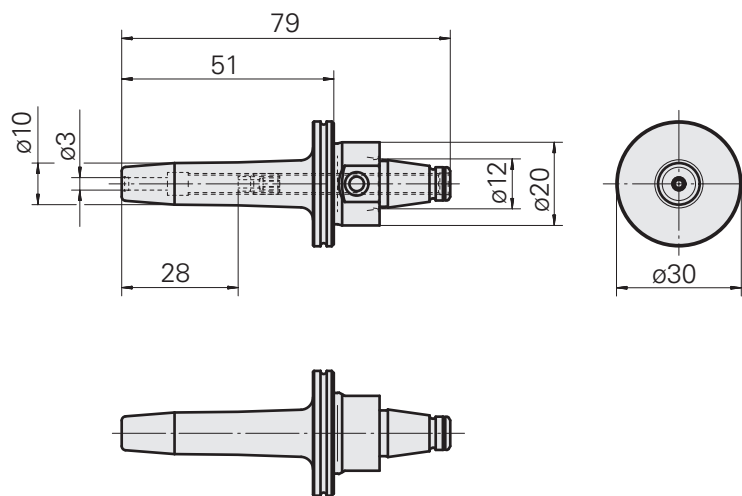

## Quick-change inserts WFB20-12

W-T shrink-fit chuck,  $\varnothing 3 \times 37$

### Accessories

Adjusting screw W&F  
326793

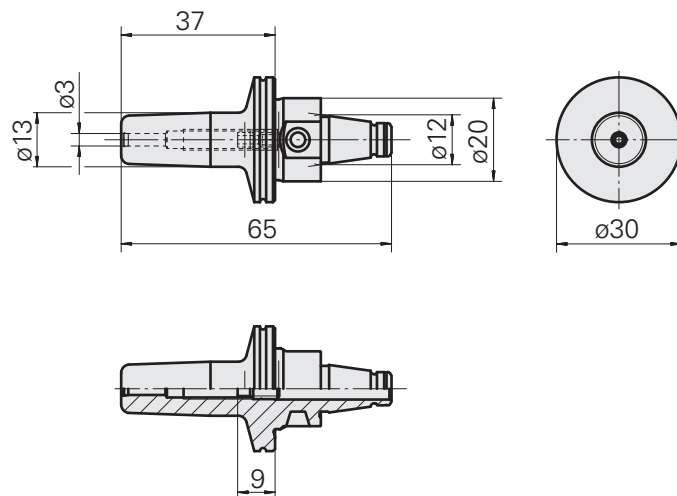

## Quick-change inserts WFB20-12

W-T shrink-fit chuck,  $\varnothing 3 \times 17$

2-piece type

### Accessories

Adjusting screw W&F  
326793

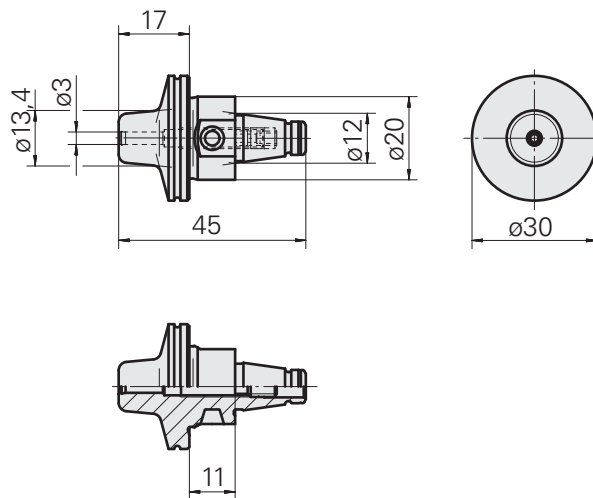

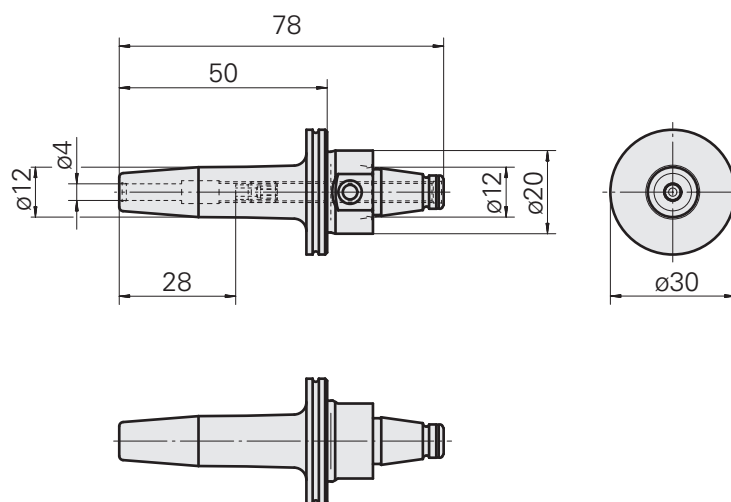
**Quick-change inserts WFB20-12**W-T shrink-fit chuck,  $\varnothing 4 \times 50$ **Accessories**Adjusting screw W&F  
326793

## Quick-change inserts WFB20-12

W-T shrink-fit chuck,  $\varnothing 4 \times 35$

### Accessories

Adjusting screw W&F  
326793

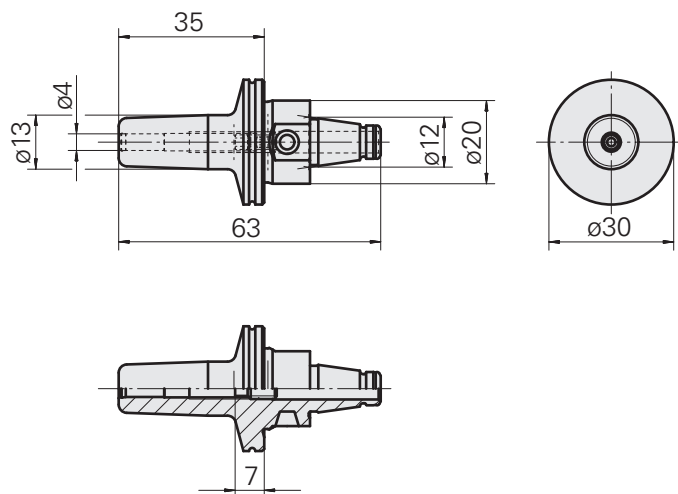



## Quick-change inserts WFB20-12

W-T shrink-fit chuck,  $\varnothing 4 \times 17$

2-piece type

### Accessories

Adjusting screw W&F  
326793

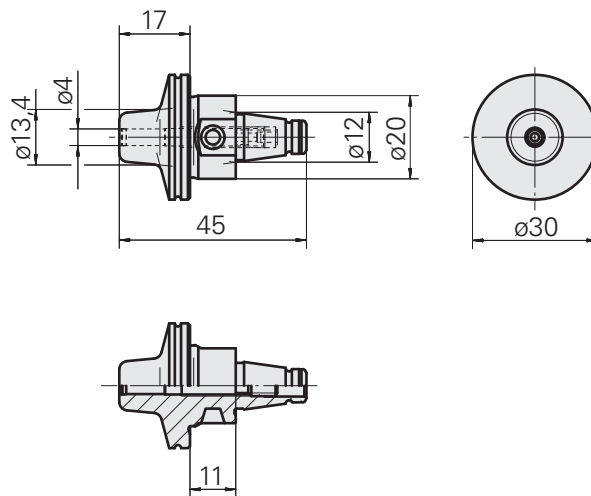

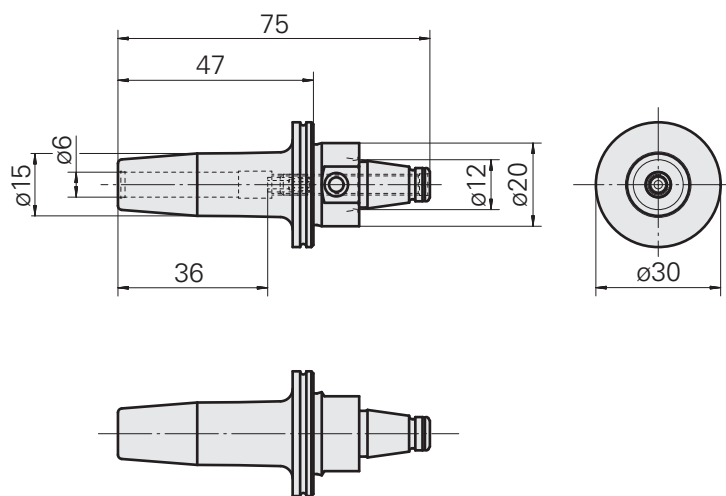
**Quick-change inserts WFB20-12**W-T shrink-fit chuck,  $\varnothing 6 \times 47$ **Accessories**Adjusting screw W&F  
326793

## Quick-change inserts WFB20-12

W-T shrink-fit chuck,  $\varnothing 6 \times 32$

### Accessories

Adjusting screw W&F  
326794

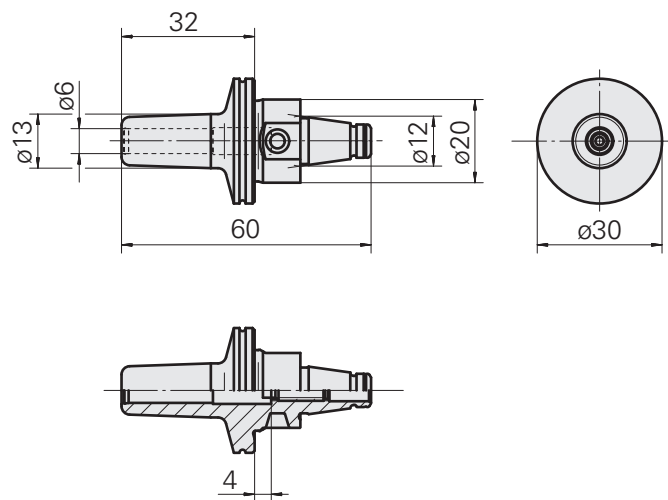

## Quick-change inserts WFB20-12

W-T shrink-fit chuck,  $\varnothing 6 \times 17$

2-piece type

### Accessories

Adjusting screw W&F  
326793

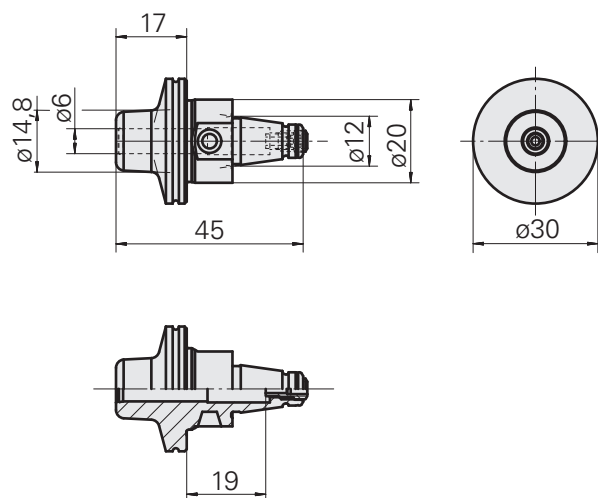

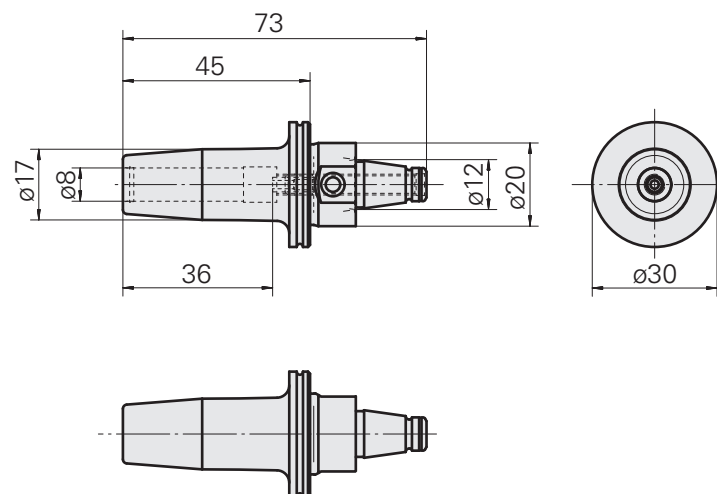
**Quick-change inserts WFB20-12**W-T shrink-fit chuck,  $\varnothing 8 \times 45$ **Accessories**Adjusting screw W&F  
326793

## Quick-change inserts WFB20-12

W-T shrink-fit chuck,  $\varnothing 8 \times 30$

### Accessories

Adjusting screw W&F  
326794

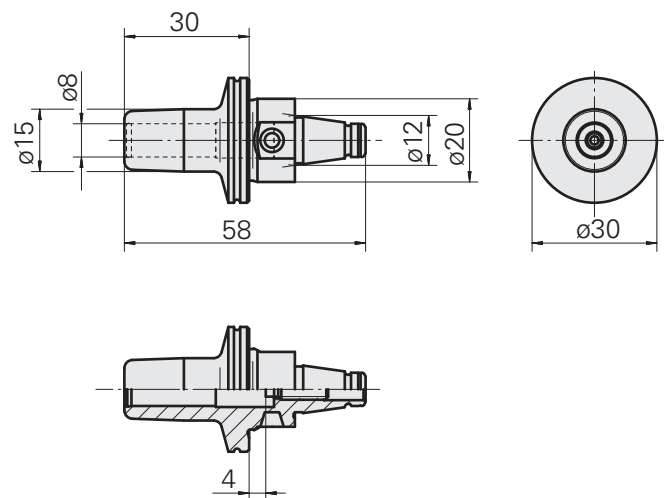

## Quick-change inserts WFB20-12

W-T shrink-fit chuck,  $\varnothing 8 \times 20$

2-piece type

### Accessories

Adjusting screw W&F  
326793

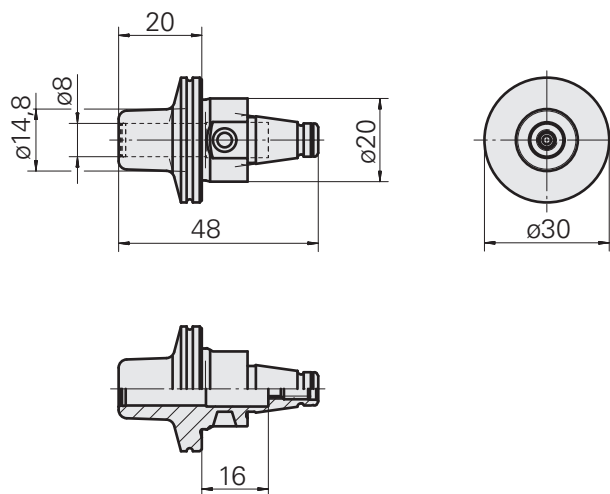

## Quick-change inserts WFB20-12

W-T shrink-fit chuck,  $\varnothing 10 \times 27$

2-piece type

### Accessories

Adjusting screw W&F  
326793

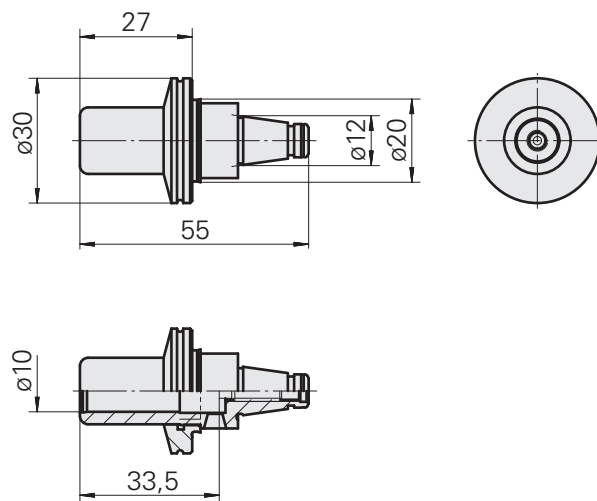



**Accessories**

**Quick-change inserts**

**WFB20-12**

**Weldon mounting**

## Quick-change inserts WFB20-12

W-T Weldon DIN 1865 form B,  $\varnothing 6 \times 43$

### Accessories

Adjusting screw W&F  
326793

Clamping screw W&F  
326789

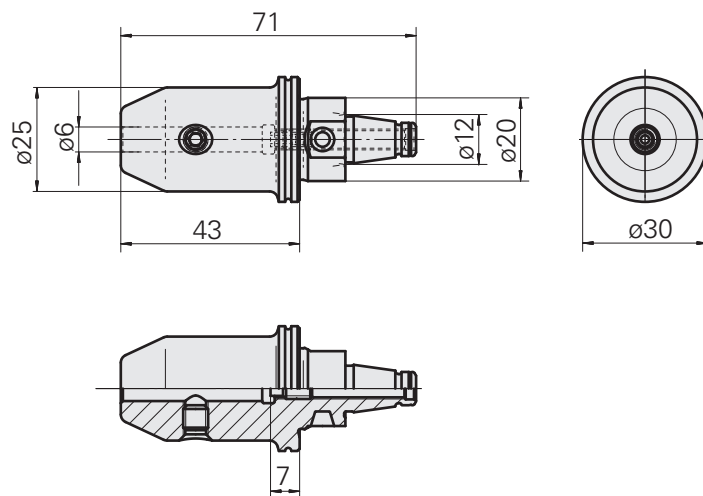

## Quick-change inserts WFB20-12

W-T Weldon DIN 1865 form B,  $\varnothing 6 \times 43$

### Accessories

Adjusting screw W&F  
326793

Clamping screw W&F  
326789

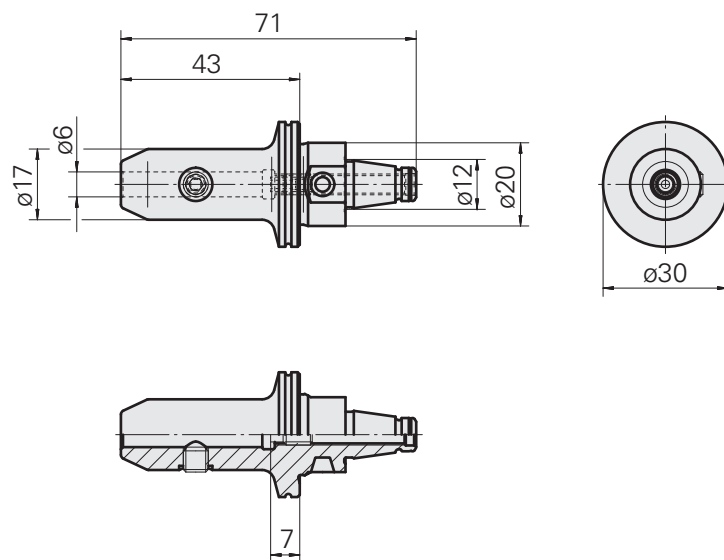

## Quick-change inserts WFB20-12

W-T Weldon DIN 1865 form B,  $\varnothing 6 \times 27.5$

### Accessories

Adjusting screw W&F  
326793

Clamping screw W&F  
326789

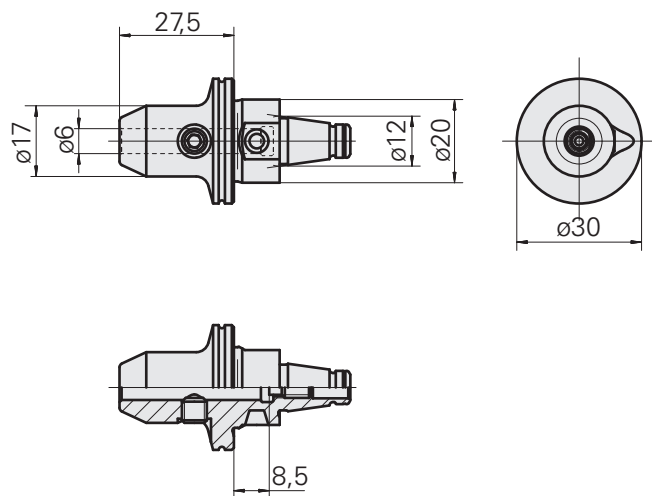

## Quick-change inserts WFB20-12

W-T Weldon DIN 1865 form B,  $\varnothing 8 \times 43$

### Accessories

Adjusting screw W&F  
326793

Clamping screw W&F  
326790

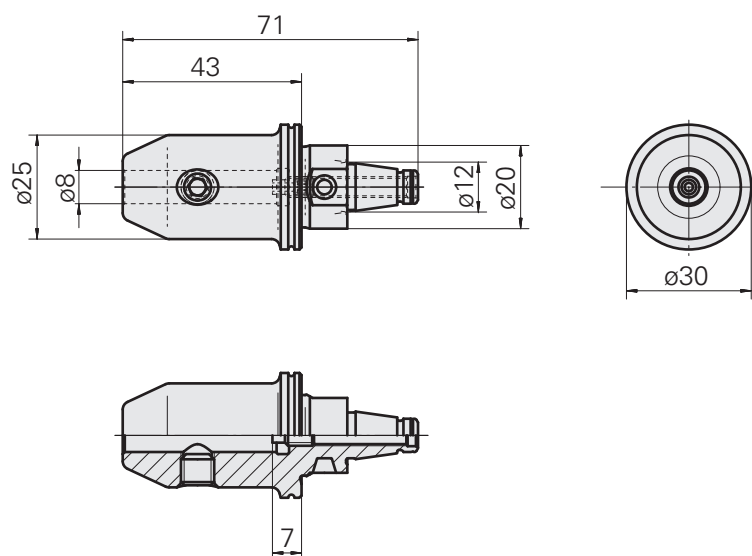

## Quick-change inserts WFB20-12

W-T Weldon DIN 1865 form B,  $\varnothing 8 \times 27.5$

### Accessories

Adjusting screw W&F  
326793

Clamping screw W&F  
326790

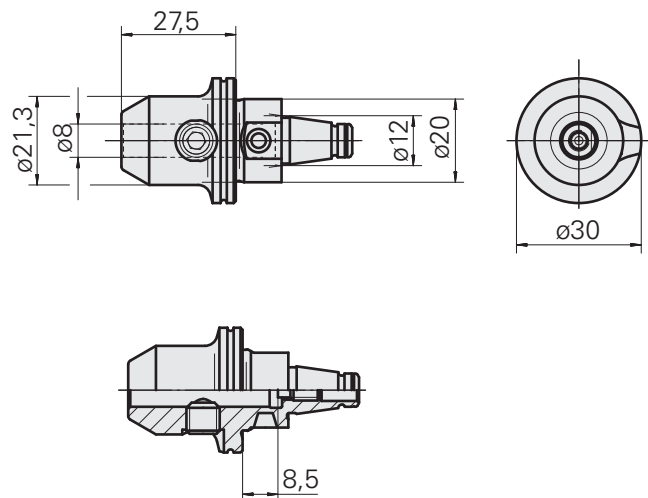

## Quick-change inserts WFB20-12

W-T Weldon DIN 1865 form B,  $\varnothing 10 \times 43$

### Accessories

Adjusting screw W&F  
326793

Clamping screw W&F  
326791

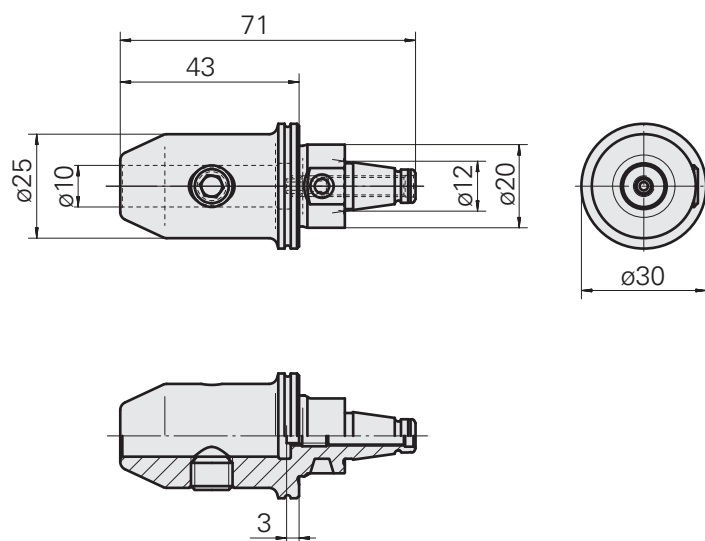





**Accessories**

**Quick-change inserts**

**WFB20-12**

**Collet mounting**

## Quick-change inserts WFB20-12

W-T collet, ER8

### Accessories

Collet 901930.8---

Clamping nut 323117

Chuck key 323118

Adjusting screw W&F  
326793

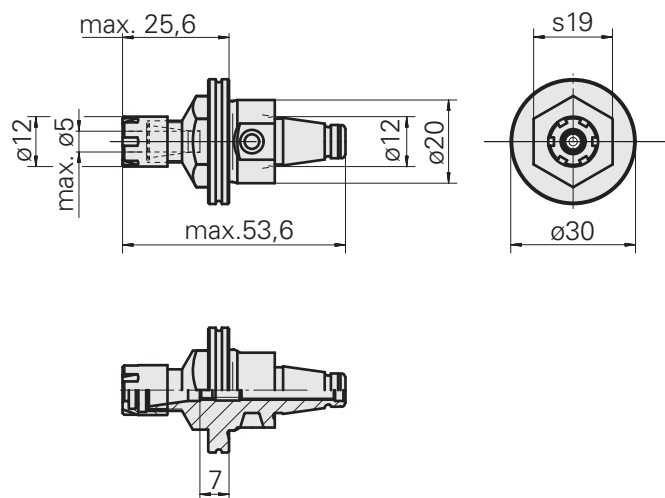

## Quick-change inserts WFB20-12

W-T collet, ER11

### Accessories

Collet 901930.0---

Tapping collet 3239--

Tapping collet 900288

Clamping nut 901939.5111

Chuck key 420219.3111

Set screw 410156.0510

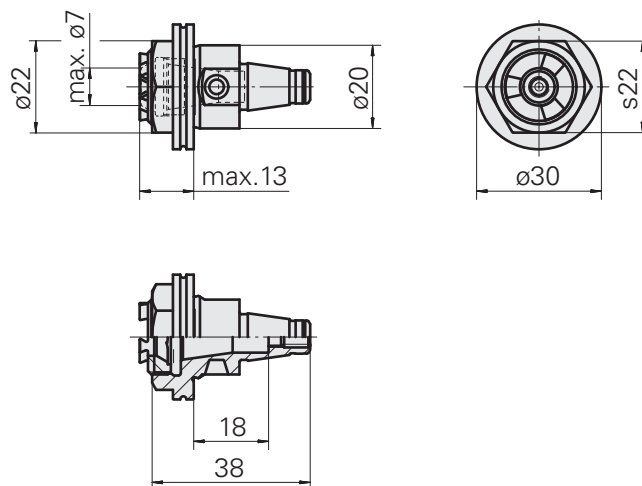

## Quick-change inserts WFB20-12

W-T collet, ER11

### Accessories

Collet 901930.0---

Tapping collet 3239--

Tapping collet 900288

Clamping nut 322438

Chuck key 490219.0111

Adjusting screw W&F  
326793

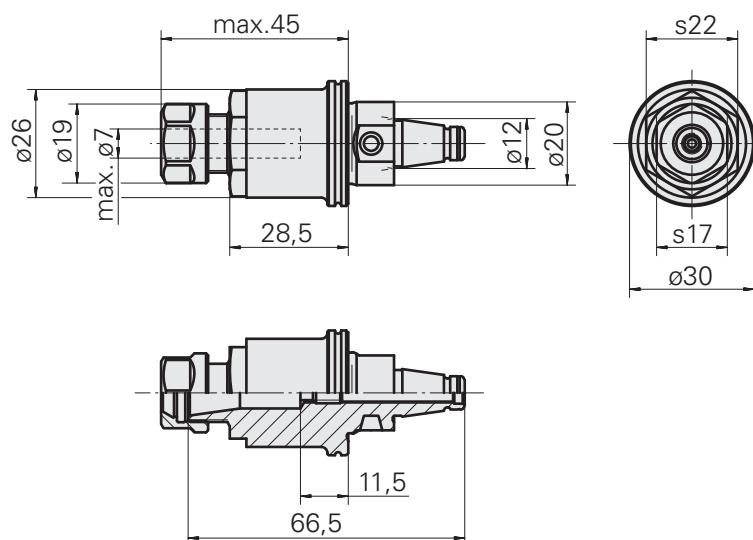

## Quick-change inserts WFB20-12

W-T collet, ER11

### Accessories

Collet 901930.0---

Tapping collet 3239--

Tapping collet 900288

Clamping nut 322438

Chuck key 490219.0111

Adjusting screw W&F  
326793

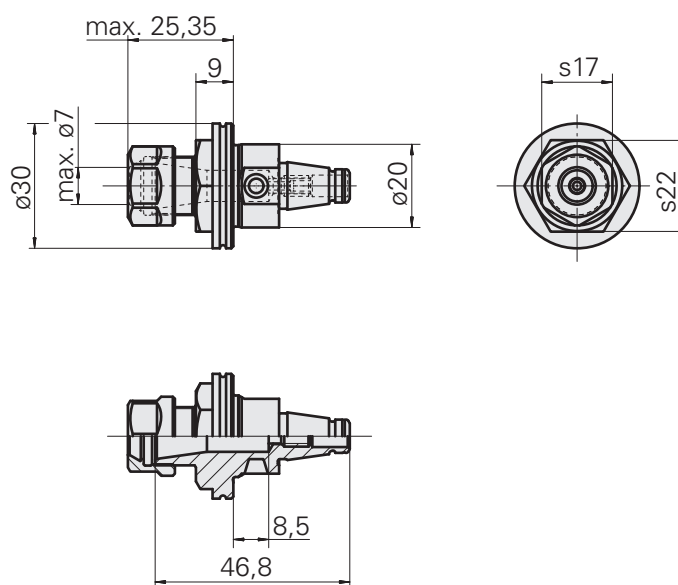

## Quick-change inserts WFB20-12

W-T collet, ER16

### Accessories

Collet ER16 901930.1---

Collet ER16UP W99903--

Thread cutting collet 3230---

Clamping nut 901939.01

Chuck key 490219.0161

Adjusting screw W&F  
326793

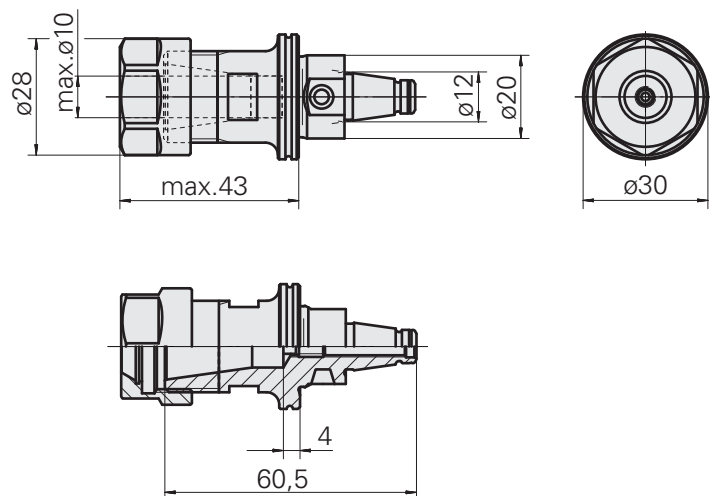

## Quick-change inserts WFB20-12

W-T collet, ER16

### Accessories

Collet ER16 901930.1---

Collet ER16UP W99903--

Thread cutting collet 3230---

Clamping nut 901939.01

Chuck key 490219.0161

Adjusting screw W&F  
326793

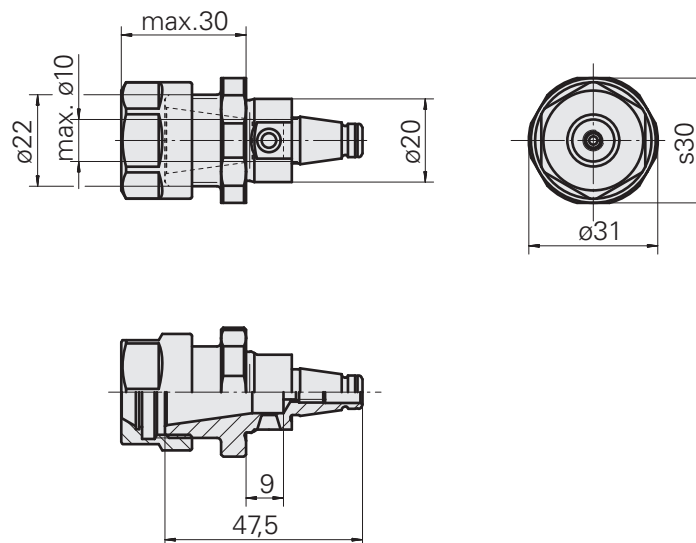

## Quick-Change Inserts WFB20-12

W-T collet, ER20

### Accessories

Collet 901930.2---

Tapping tool collet 3234--

Clamping nut 901939.0201

Chuck key 490219.0201

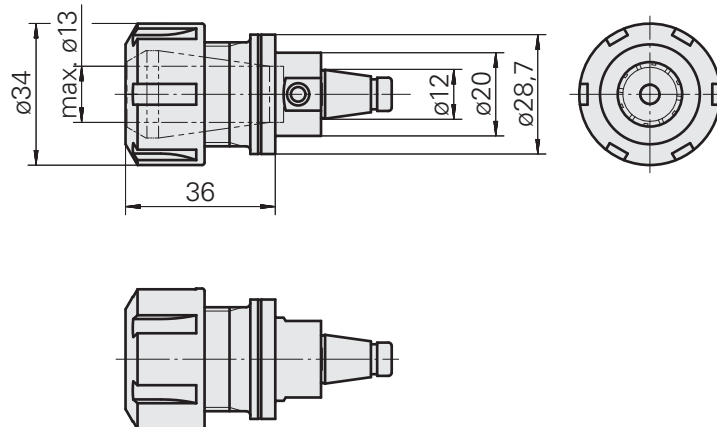



## Quick-Change Inserts WFB20-12

W-T collet, ER25

### Accessories

Collet 901930.3---

Tapping tool collet 3224--

Tapping tool collet  
WZ9990.9507F

Clamping nut 901939.2251

Chuck key 490219.2251

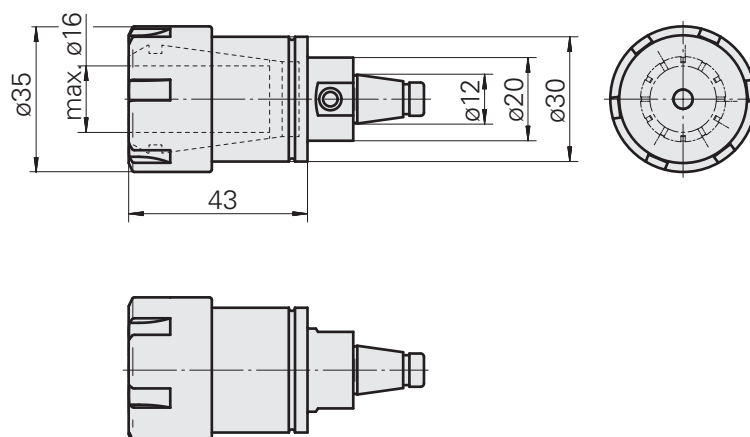

## Quick-Change Inserts WFB20-12

W-T collet, ER25

### Accessories

Collet 901930.3---

Tapping tool collet 3224--

Tapping tool collet  
WZ9990.9507F

Clamping nut 901939.0251

Chuck key 490219.0251

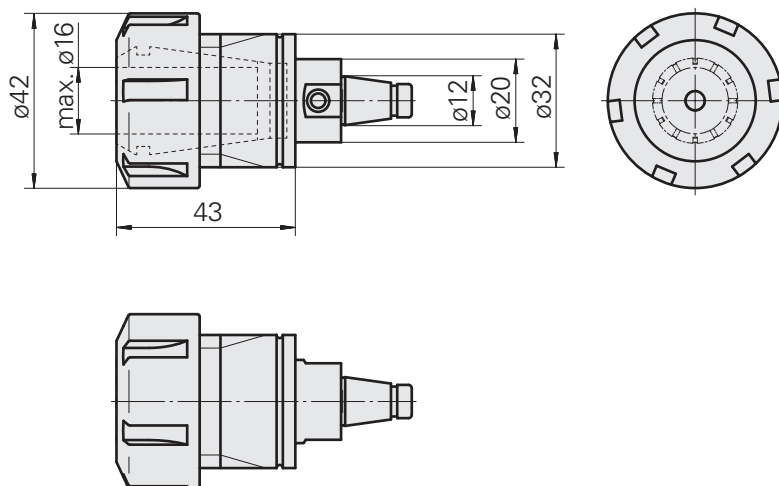

**Accessories**

**Quick-change inserts**

**WFB20-12**

**Mill arbor mounting**

## Quick-change inserts WFB20-12

W-T mill arbor,  $\varnothing 5$

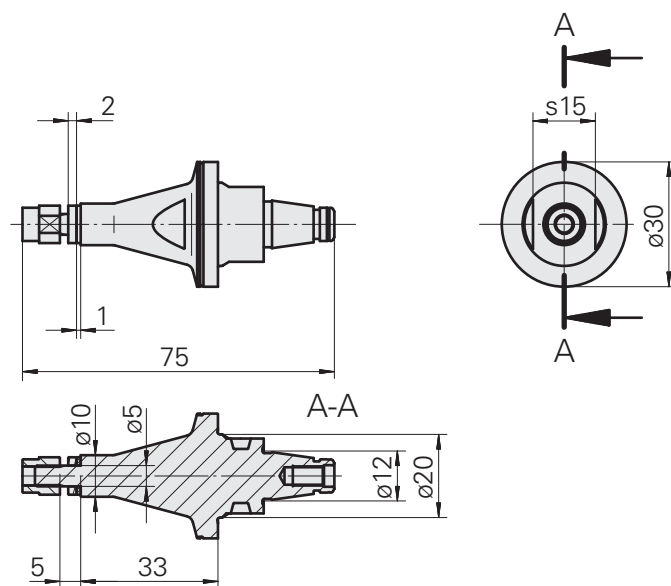

## Quick-change inserts WFB20-12

W-T mill arbor,  $\varnothing 8$

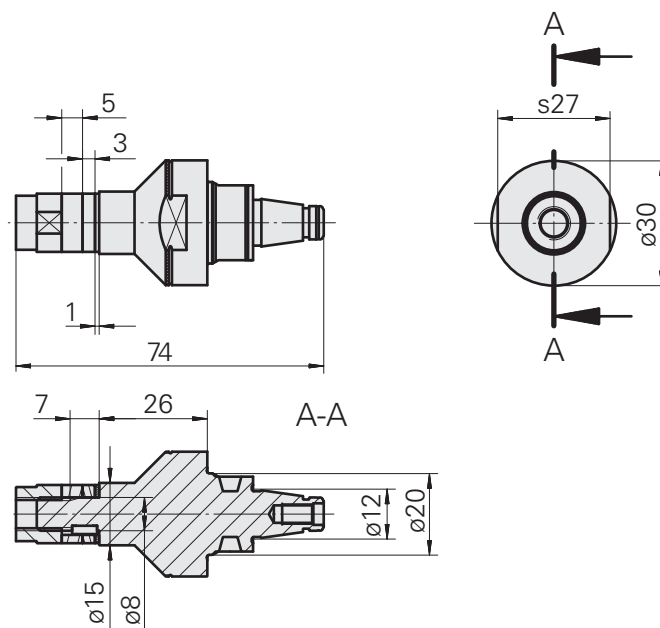

## Quick-change inserts WFB20-12

W-T mill arbor,  $\varnothing 10$

### Accessories

Rings  
251390.----  
251391.----

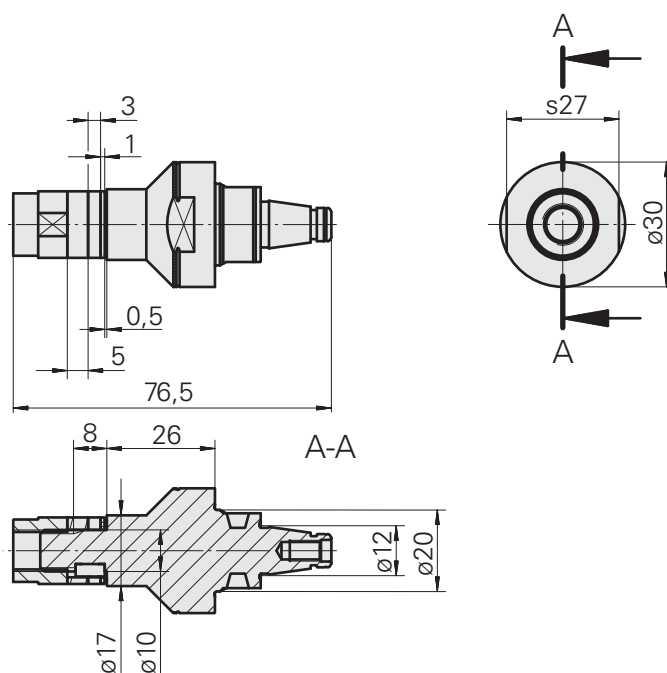

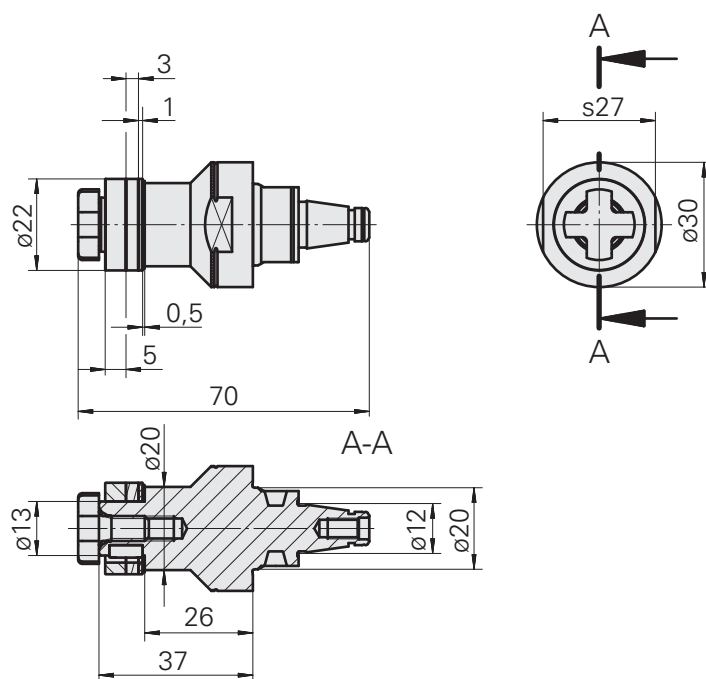
**Quick-change inserts WFB20-12**W-T mill arbor,  $\varnothing 13$ **Accessories**Rings  
251390.----  
251391.----Mill arbor wrench  
203020.1130

## Quick-change inserts WFB20-12

W-T mill arbor,  $\varnothing 16$

### Accessories

Rings  
251390.----  
251391.----

Mill arbor wrench  
203020.1160

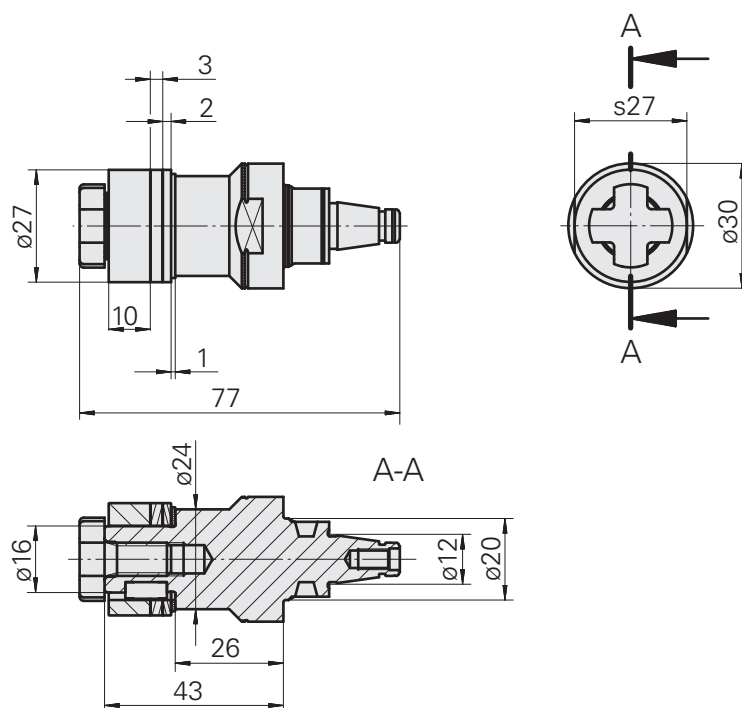

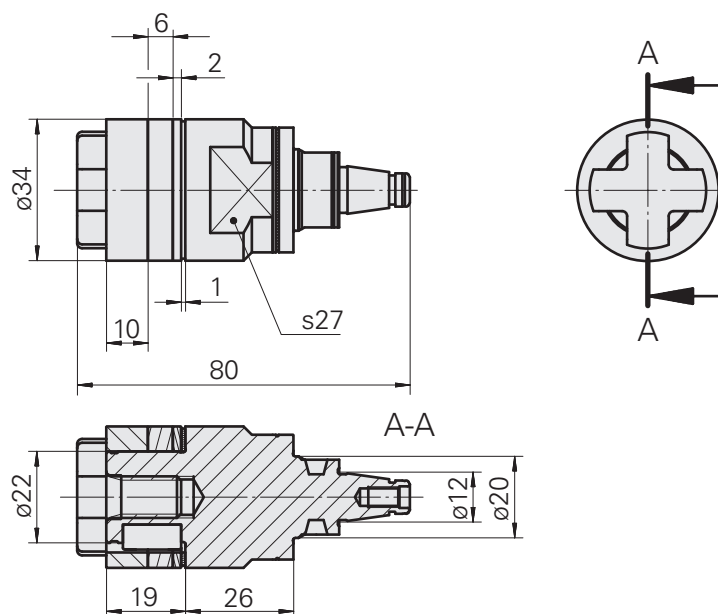

**Quick-change inserts WFB20-12**W-T mill arbor,  $\varnothing 22$ **Accessories**Rings  
251390.----  
251391.----Mill arbor wrench  
203020.1220



**Accessories**

**Quick-change inserts**

**WFB20-12**

**Hydraulic expansion mounting**

## Quick-change inserts WFB20-12

W-T Hydro-expand,  $\varnothing 6$

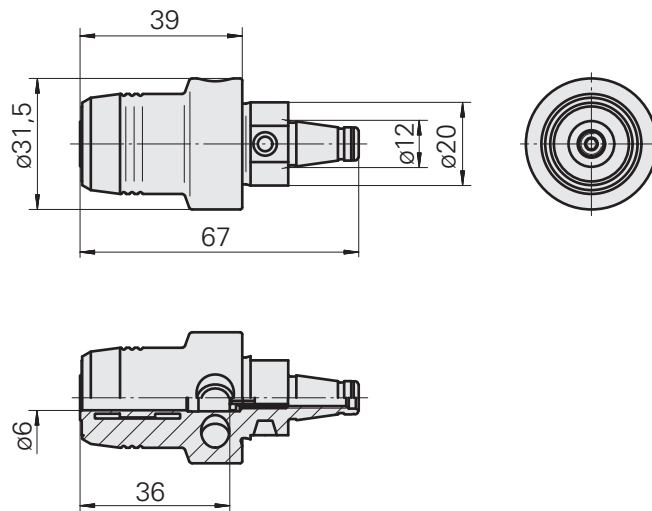

## Quick-change inserts WFB20-12

W-T Hydro-expand,  $\varnothing 8$

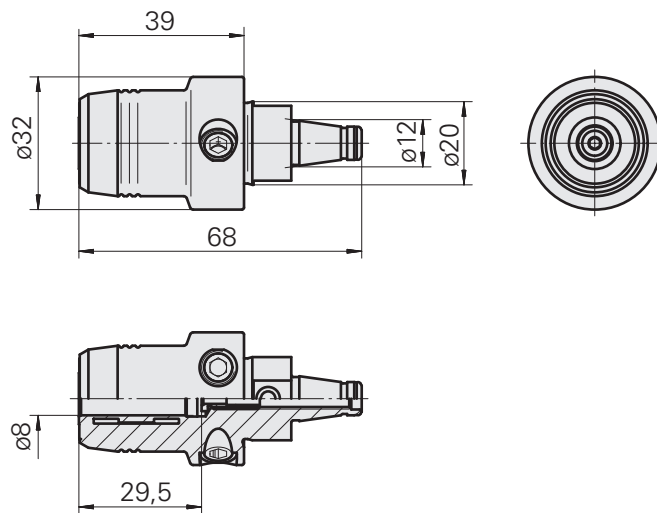



**Accessories**

**Quick-change inserts**

**WFB20-12**

**Boring tool holder**

## Quick-change inserts WFB20-12

W-T mounting,  $\varnothing 6 \times 40$

### Accessories

Adjusting screw W&F  
326794

Set screw  
410156.0605

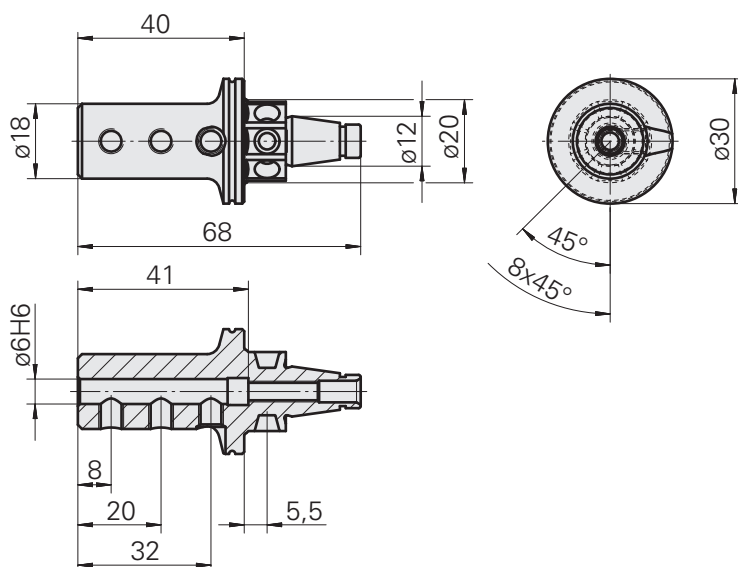



## Quick-change inserts WFB20-12

W-T mounting,  $\varnothing 8 \times 40$

### Accessories

Adjusting screw W&F  
326794

Set screw  
410156.0608

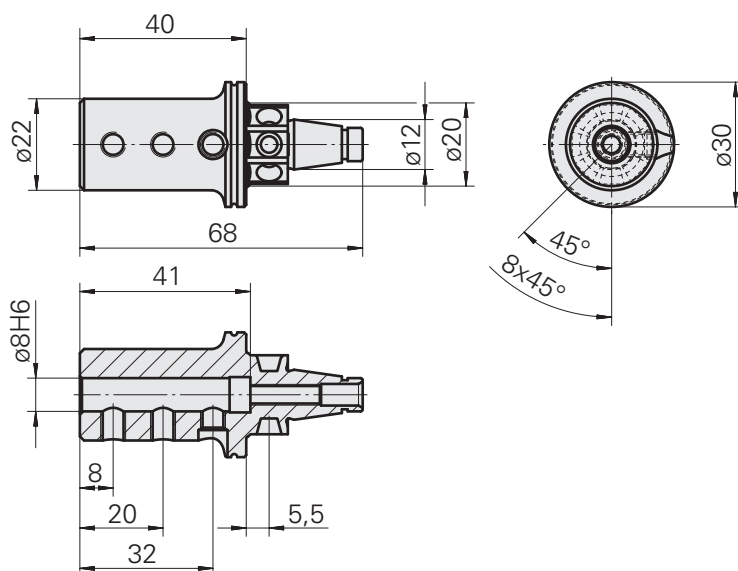



## Quick-change inserts WFB20-12

W-T mounting,  $\varnothing 12 \times 40$

### Accessories

Mounting sleeve  
W94280.21--

Adjusting screw W&F  
326794

Set screw  
410156.0808

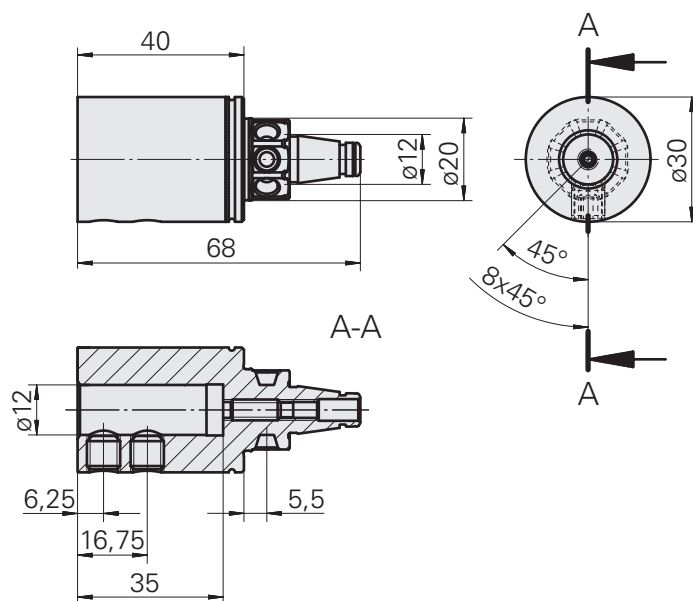

## Quick-change inserts WFB20-12

W-T mounting,  $\varnothing 16 \times 40$

### Accessories

Mounting sleeve  
W67511.04--

Adjusting screw W&F  
326794

Set screw  
410156.0808

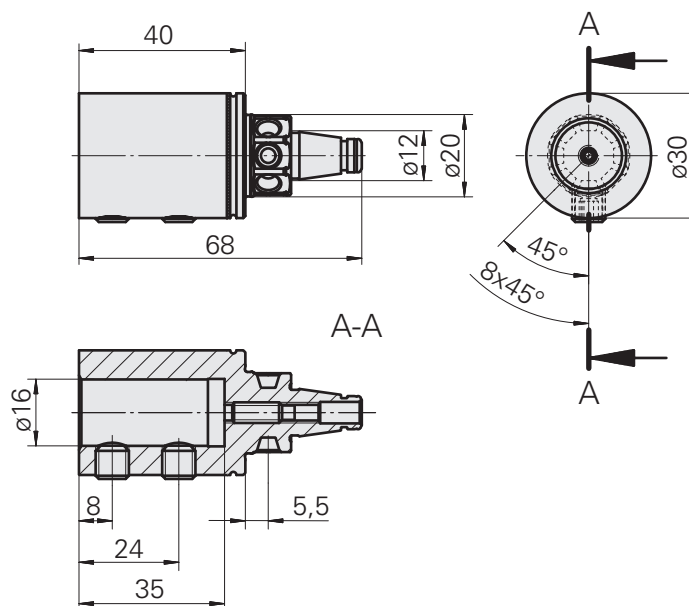

## Quick-change inserts WFB20-12

W-T mounting,  $\varnothing 20 \times 40$

### Accessories

Mounting sleeve  
W68510.04--

Adjusting screw W&F  
326794

Set screw  
410156.0808

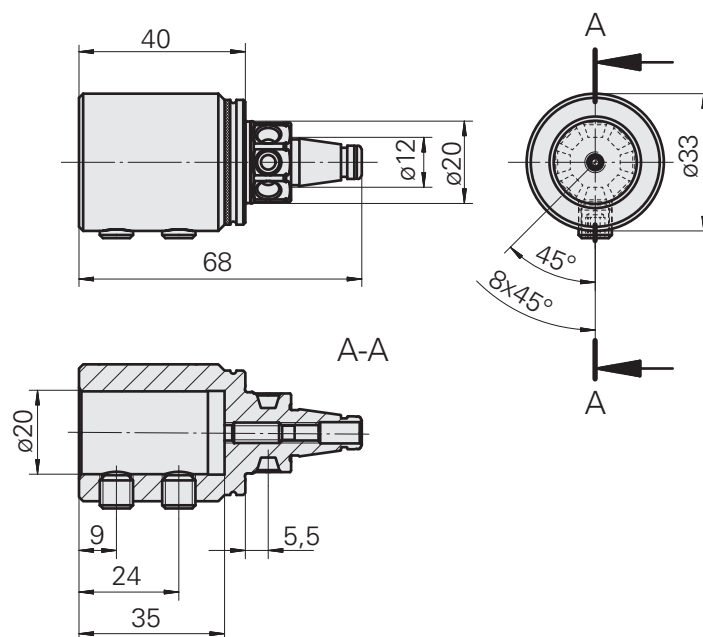

## Quick-change inserts WFB20-12

W-T mounting,  $\varnothing 1/8$ "x40

### Accessories

Adjusting screw W&F  
326794

Set screw  
410156.0304

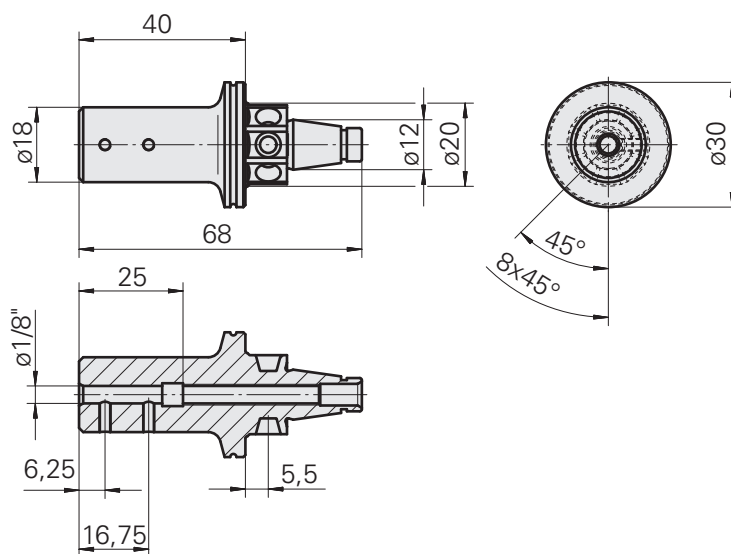

## Quick-change inserts WFB20-12

W-T mounting,  $\varnothing 3/16$ "x40

### Accessories

Adjusting screw W&F  
326794

Set screw  
410156.0405

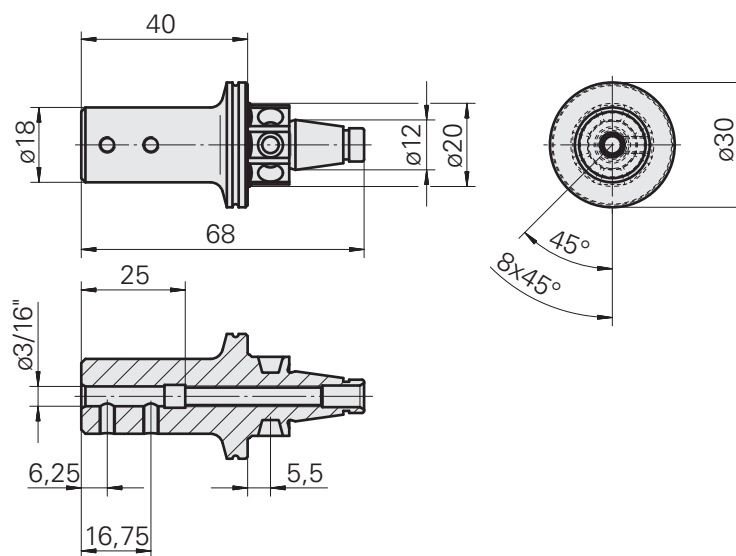

## Quick-change inserts WFB20-12

W-T mounting,  $\varnothing 1/4"$ x40

### Accessories

Adjusting screw W&F  
326794

Set screw  
410156.0605

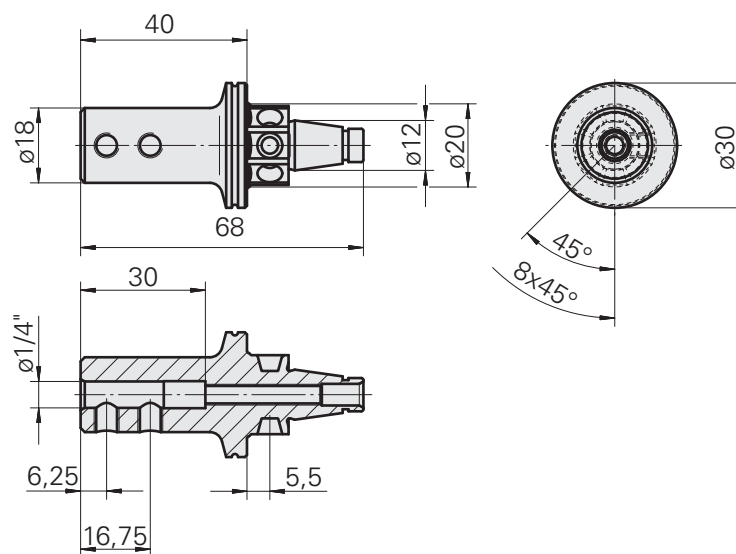



## Quick-change inserts WFB20-12

W-T mounting,  $\text{\O}3/4"$ x40

### Accessories

Adjusting screw W&F  
326794

Set screw  
410156.0808

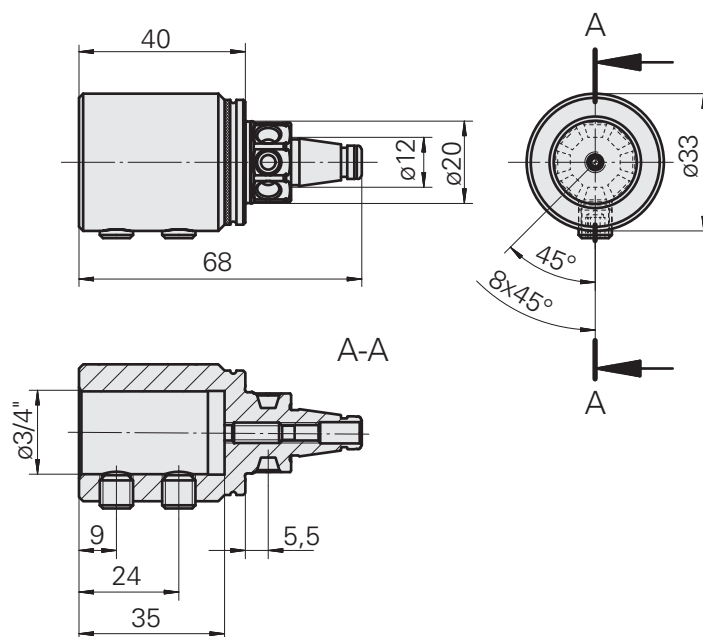



**Accessories**

**Quick-change inserts**

**WFB20-12**

**Horn S-Mini**

## Quick-change inserts WFB20-12

W-T Horn clamping holder, type B114, left

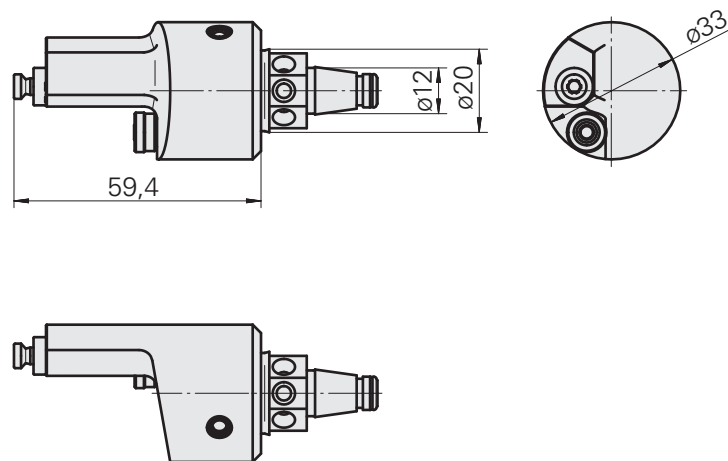

**Quick-change inserts WFB20-12**

W-T Horn S-mini, Type 105

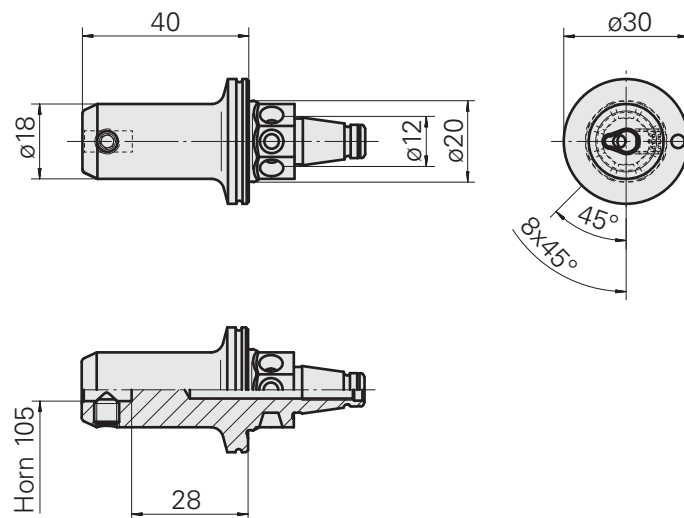
**Accessories**Set screw  
410156.0606

**Quick-change inserts WFB20-12**

W-T Horn S-mini, Type 105

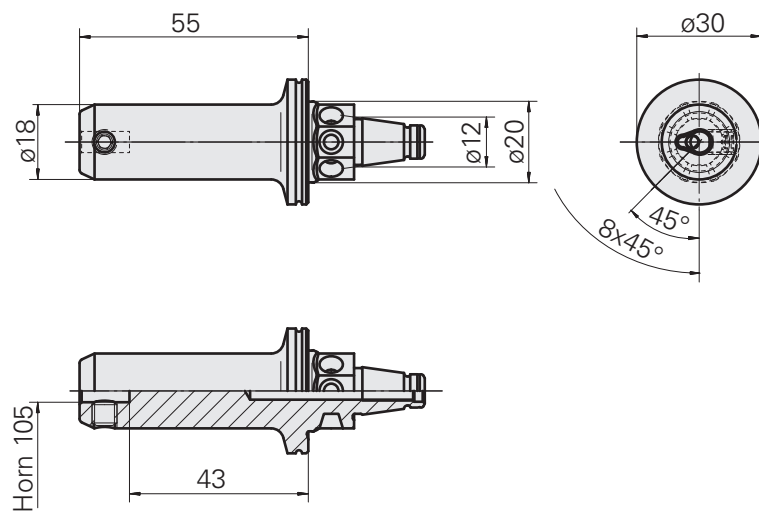
**Accessories**Set screw  
410156.0606

**Quick-change inserts WFB20-12**

W-T Horn S-mini, Type 110

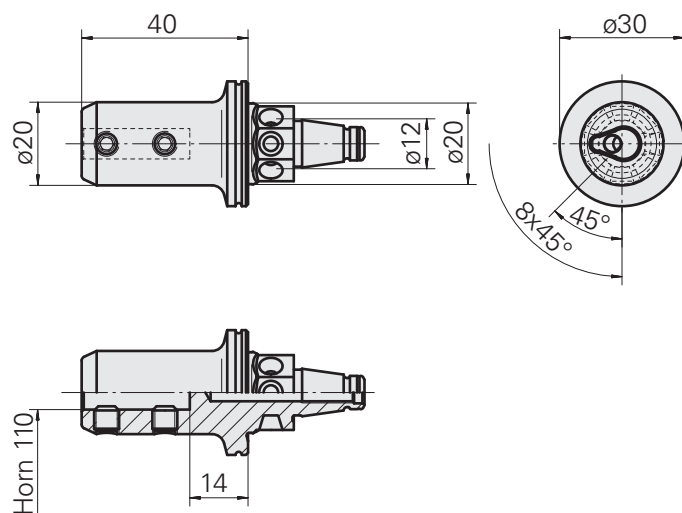
**Accessories**Set screw  
410156.0606





**Accessories**

**Quick-change inserts**

**WFB20-12**

**Turning tool holder**

## Quick-change inserts WFB20-12

W-T turning tool holder for CC.. 09T3..

right-hand version

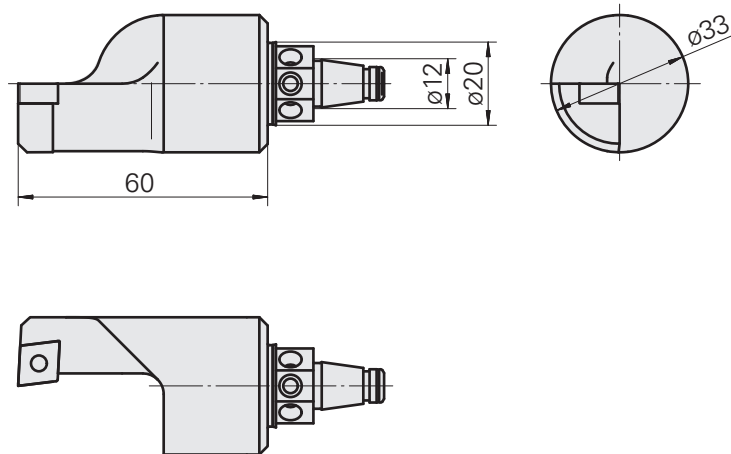

## Quick-change inserts WFB20-12

W-T turning tool holder for DC.. 11T3..

right-hand version

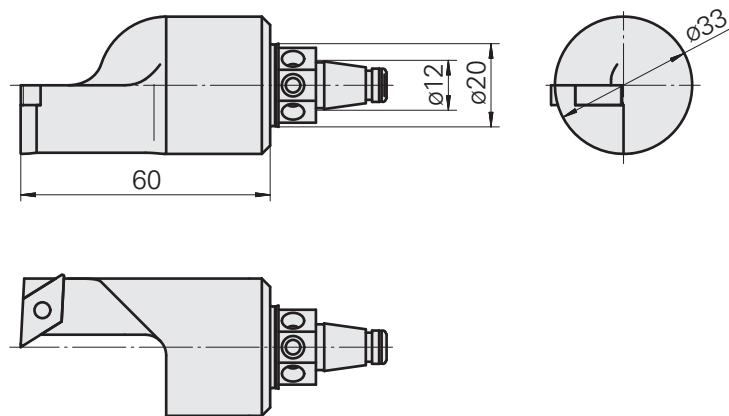

## Quick-change inserts WFB20-12

W-T turning tool holder for VC.. 1103..

right-hand version

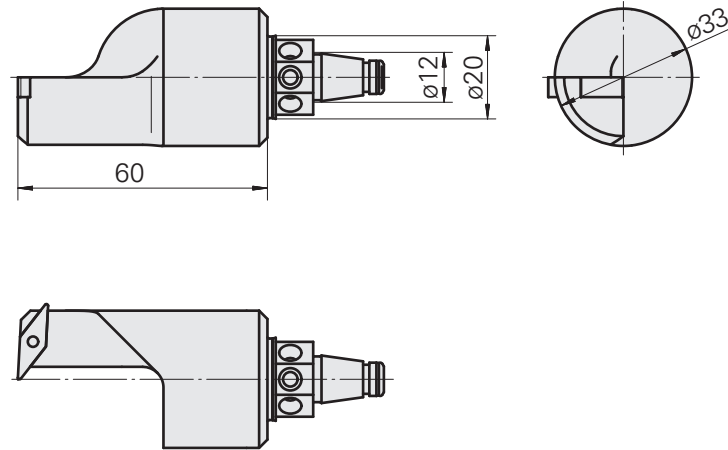

## Quick-change inserts WFB20-12

W-T turning tool holder for CC.. 09T3..

left-hand version

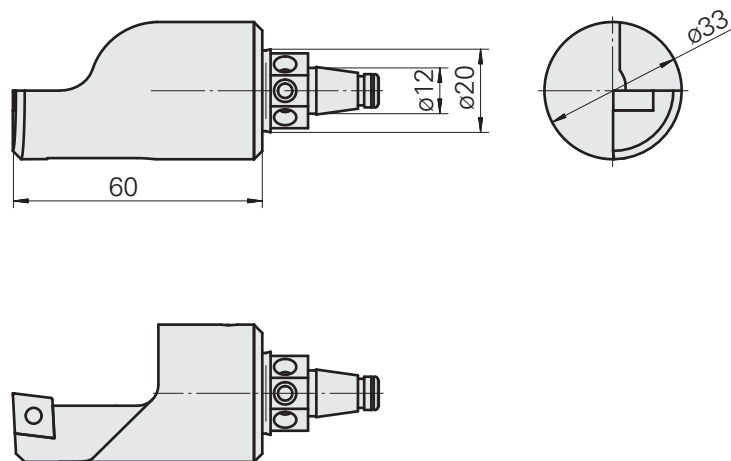

## Quick-change inserts WFB20-12

W-T turning tool holder for DC.. 11T3..

left-hand version

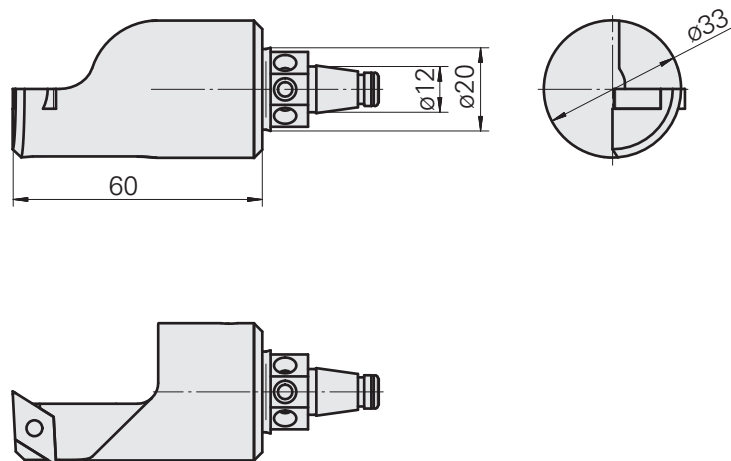

## Quick-change inserts WFB20-12

W-T turning tool holder for VC.. 1103..

left-hand version

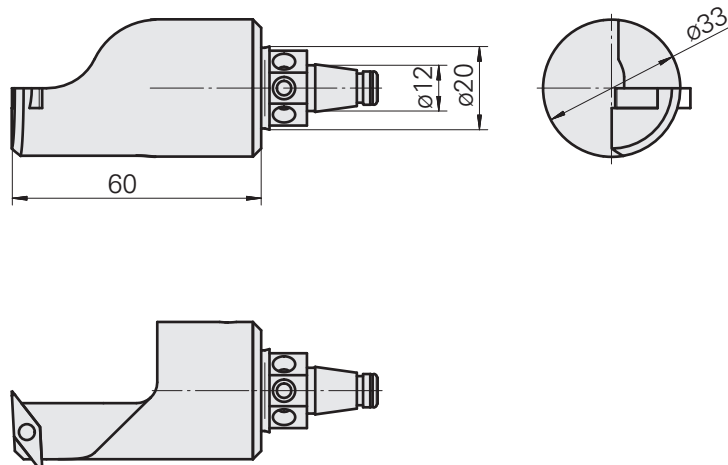

## Quick-Change Inserts WFB20-12

square 12x12

right exposition

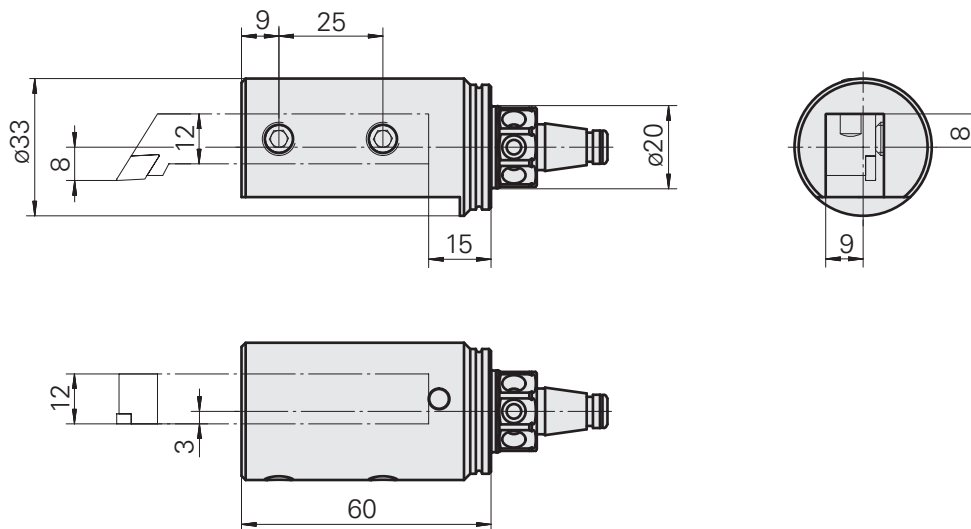



**Accessories**

**Quick-change inserts**

**WFB20-12**

**Tap chuck**

## Quick-change inserts WFB20-12

W-T thread cutting chuck GR1

### Accessories

Tapping collet  
900288

Clamping nut  
326681

Chuck key  
326792

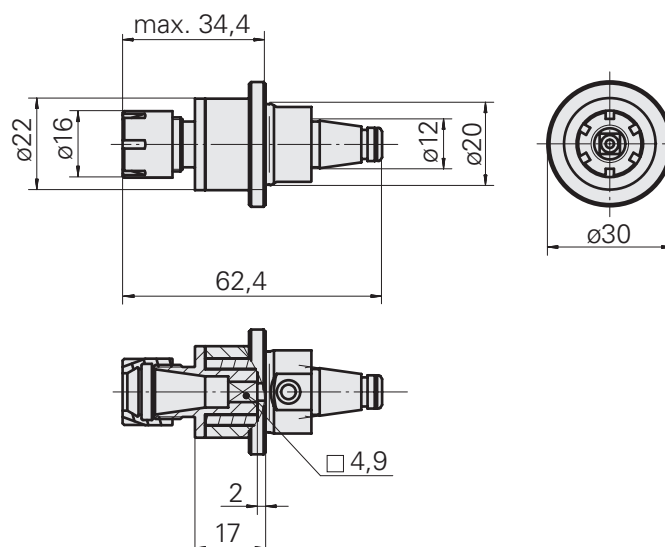

**Accessories**

**Quick-change inserts**

**WFB20-12**

**Miscell.**

## Quick-change inserts WFB20-12

W-T shrink-fit position,  $\varnothing 12$

Horn type 108-111-114-116 w round shank, see drawing 900601

### Accessories

Fixing pin  
900812

Adjusting screw  
326794

Ball-ended thrust screw  
326795

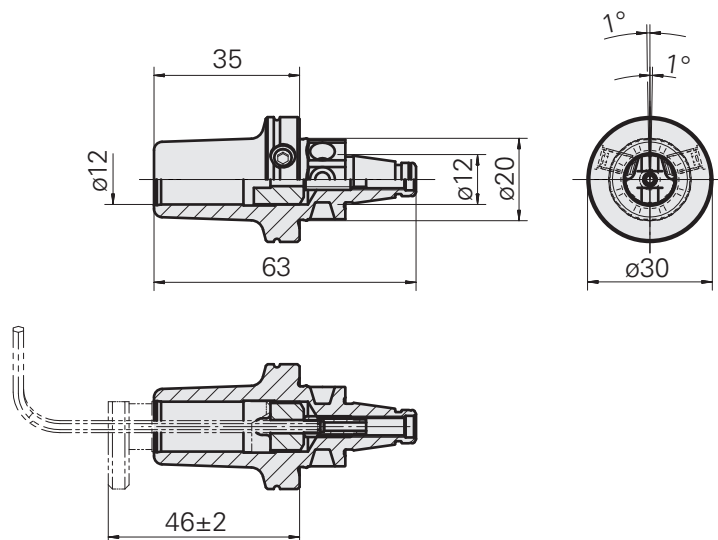

## Quick-change inserts WFB20-12

W-T extension 20 mm

### Accessories

Set screw  
326171

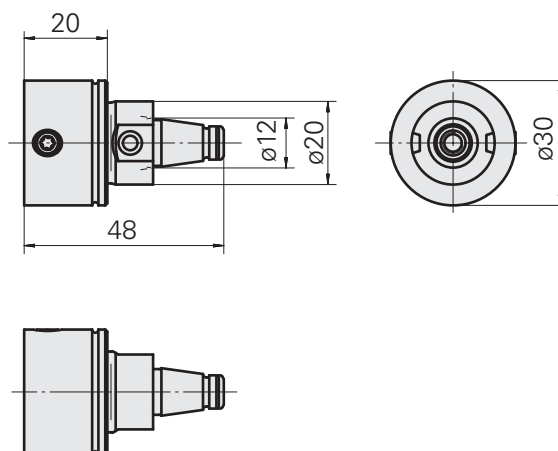

## Quick-change inserts WFB20-12

W-T adapter for broaching tool

### Accessories

Broaching tool, internal  
983305

Broaching tool, external  
983306

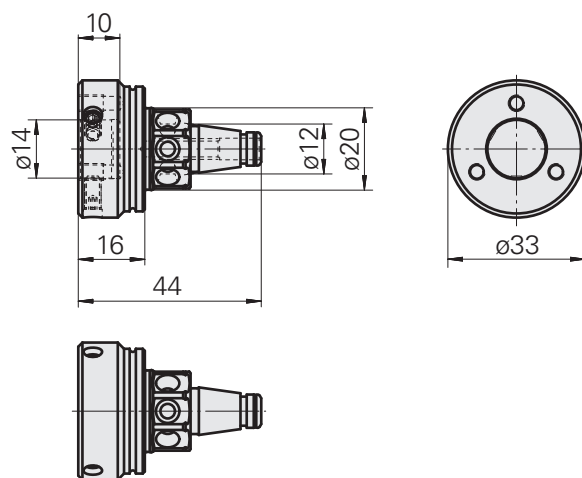

## Quick-change inserts WFB20-12

W-T blanking plugs

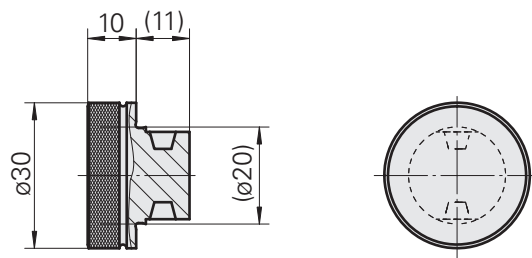

## Receptacle, WFB20-12

Shrink-fit

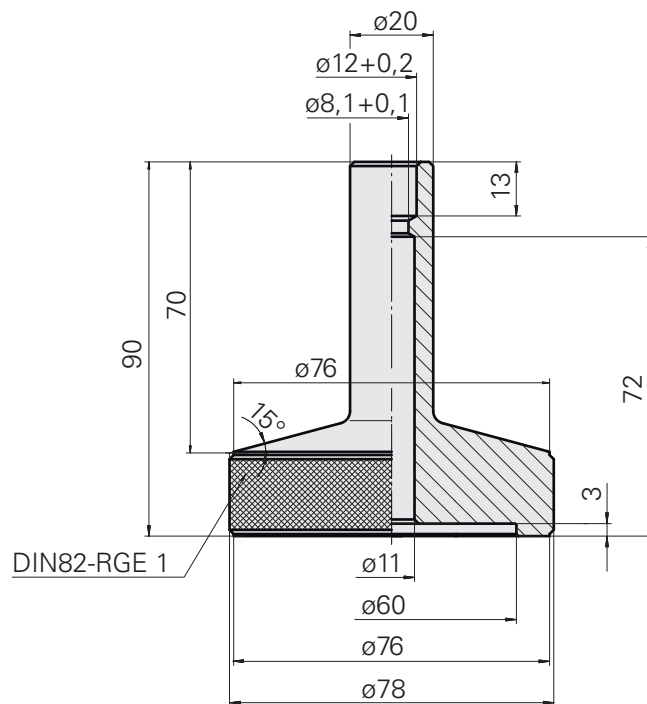



## **Accessories**

**TRAUB TNL 18P**

**TRAUB TNL 18-7**

**TRAUB TNL 18-7B**

**TRAUB TNL 18-9**

---

## Adjusting Gauge, Turning Tools

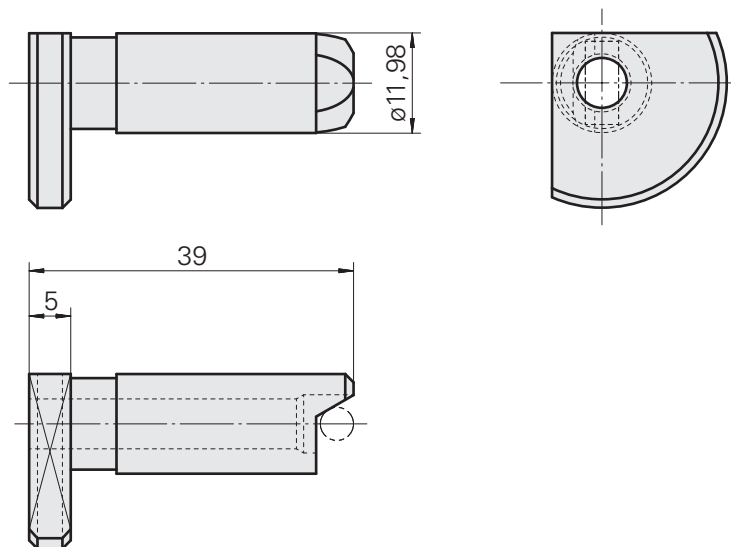

Round Shank Drawing  $\varnothing 12$

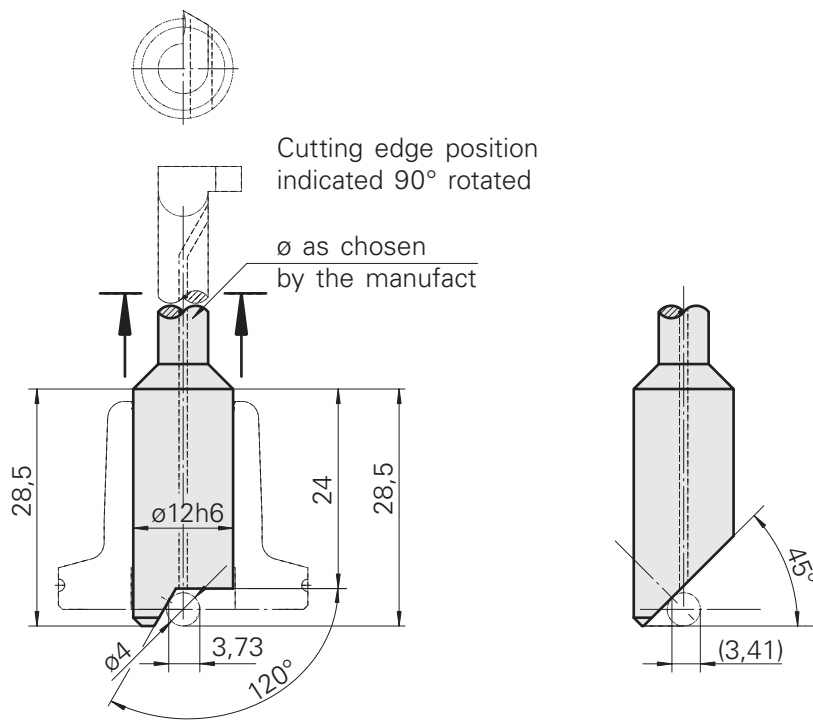

Shape 1

Shape 2

Preferably  
use  
use

## Rotary Delivery Device

Coolant delivery device

with stationary tool holders up to 120 bar  
with live tool holders up to 30 bar

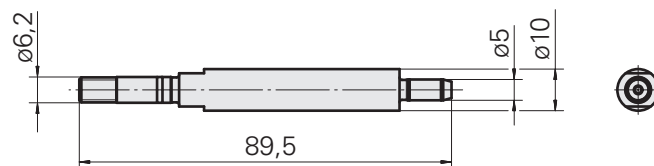

## Rotary Delivery Device

Coolant delivery device

with live tool holders up to 120 bar

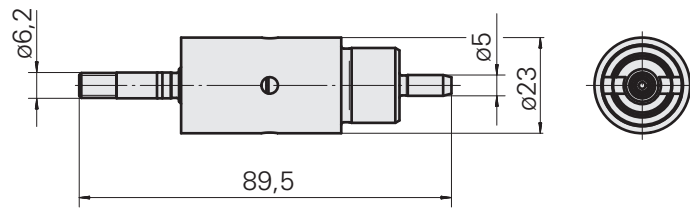

## Axial thread rolling head

F1C1

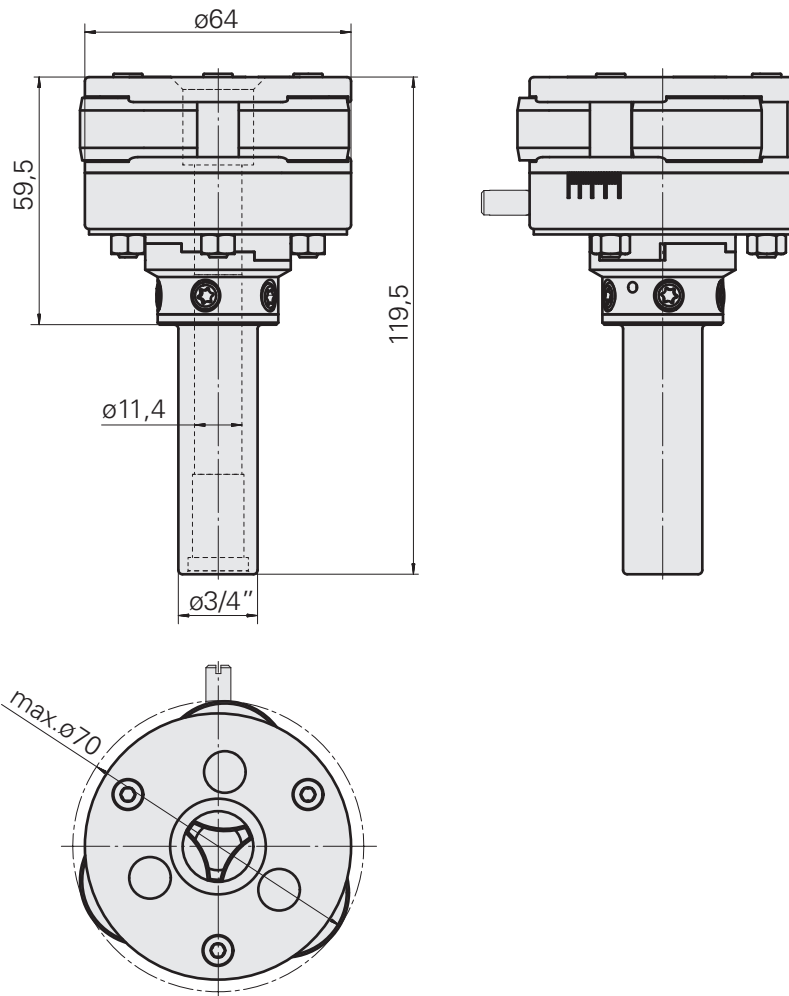

## Axial thread rolling head

F2C2

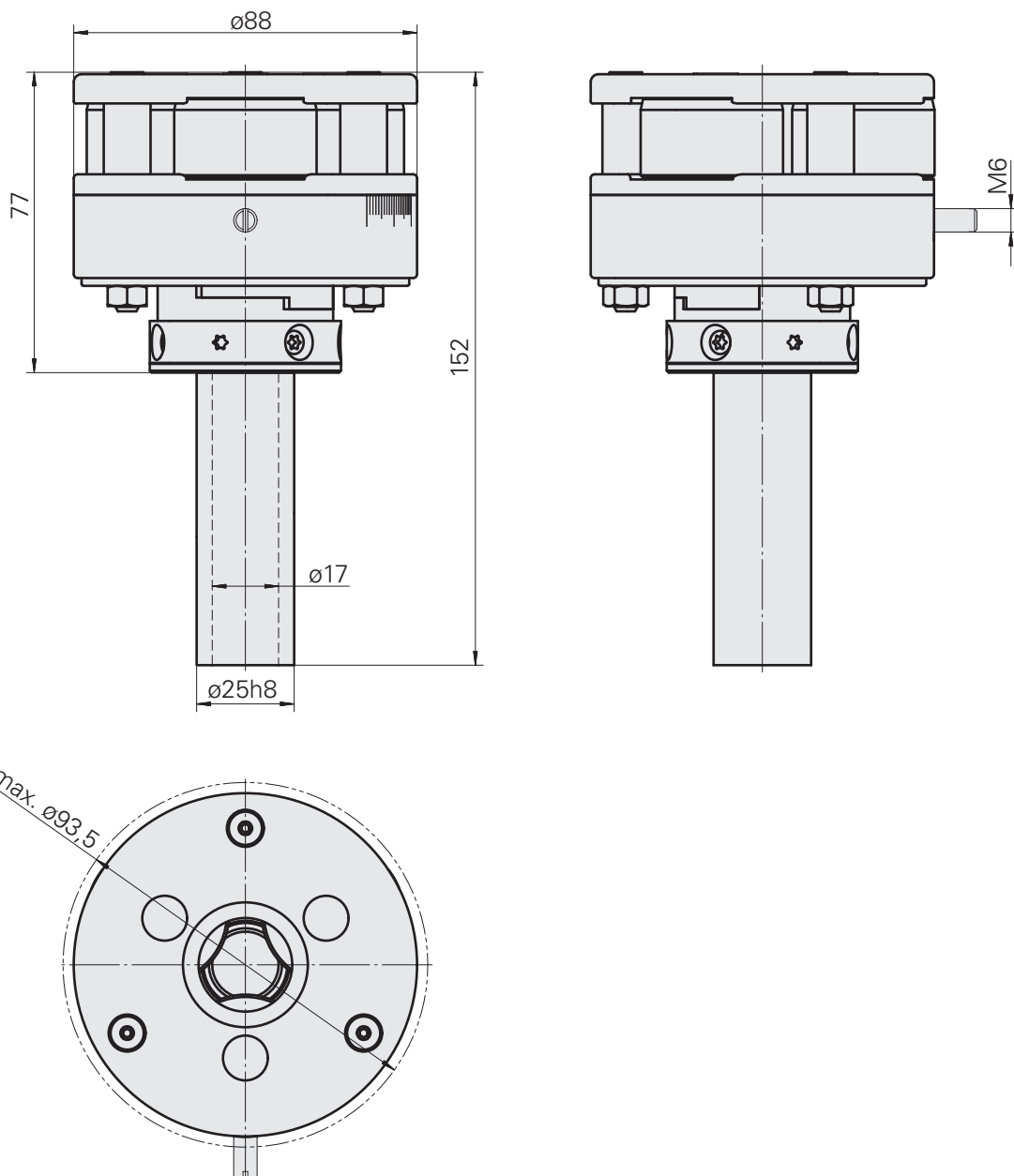

## Axial thread rolling head

Wagner, type RS10

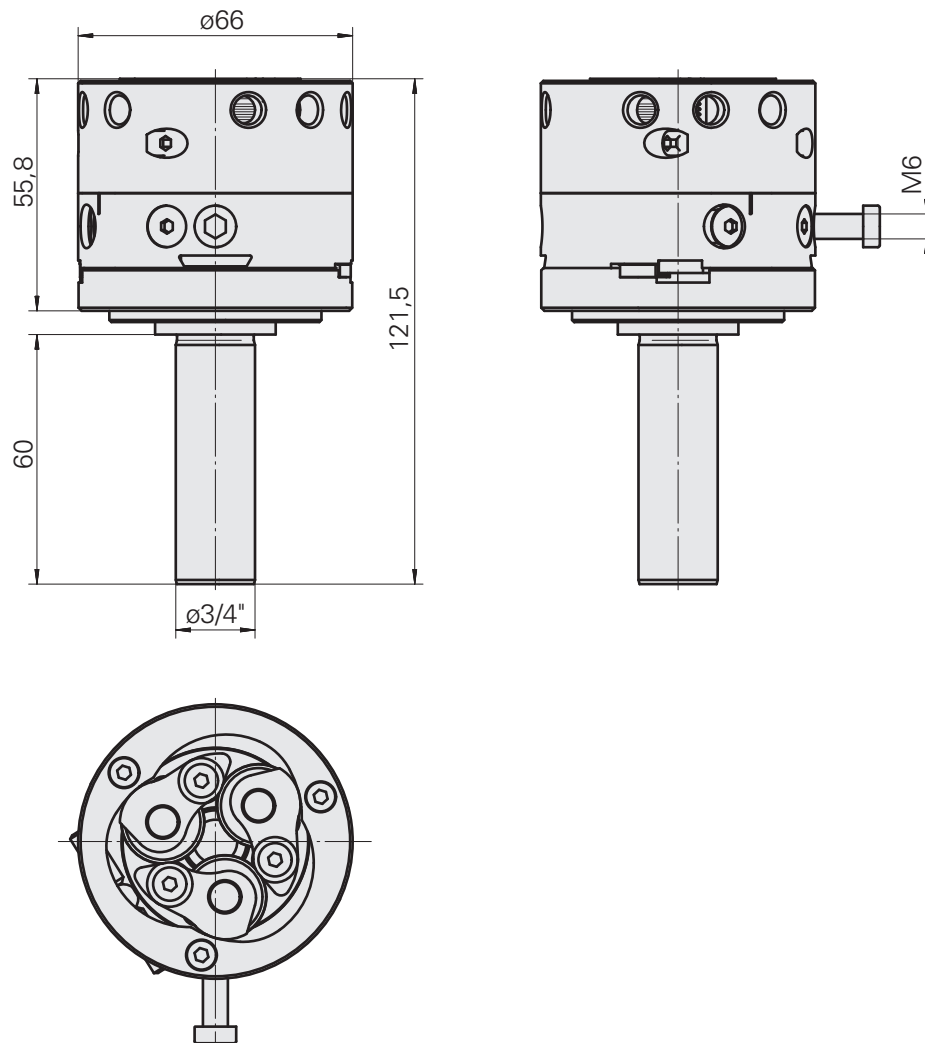



## Axial thread rolling head

Wagner, type RS16

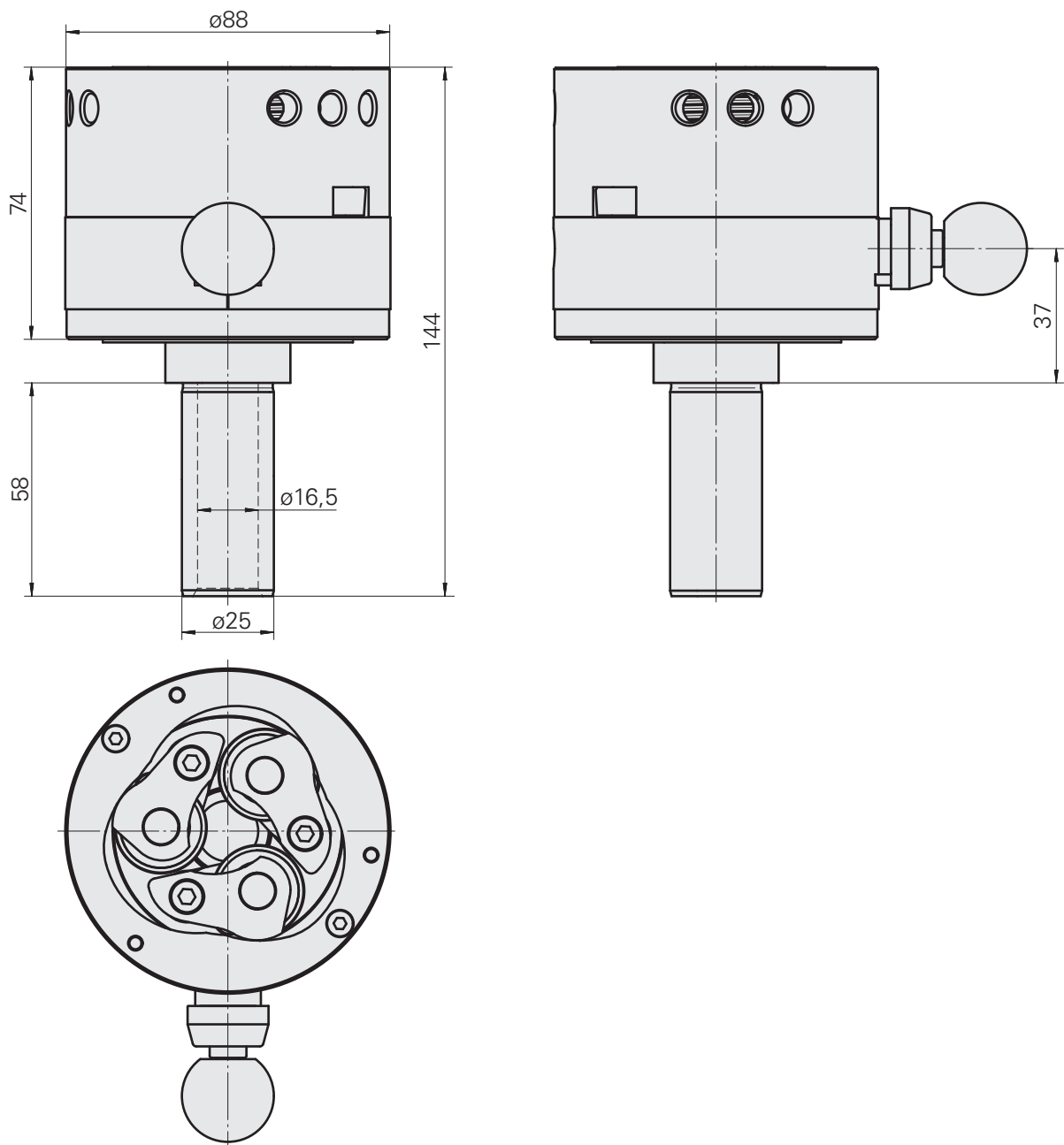

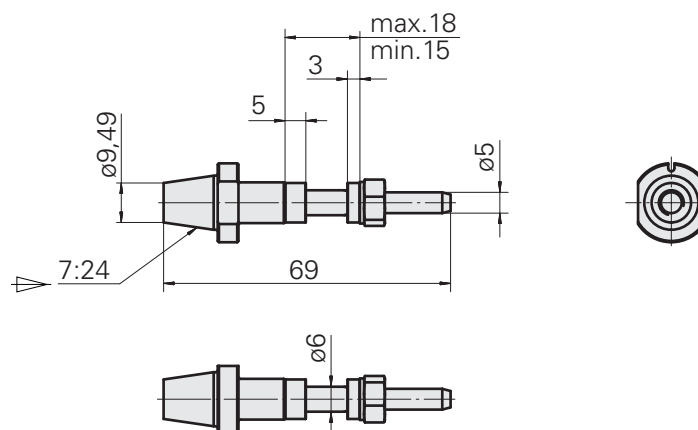
Receptacle arbor,  $\varnothing 6$ 

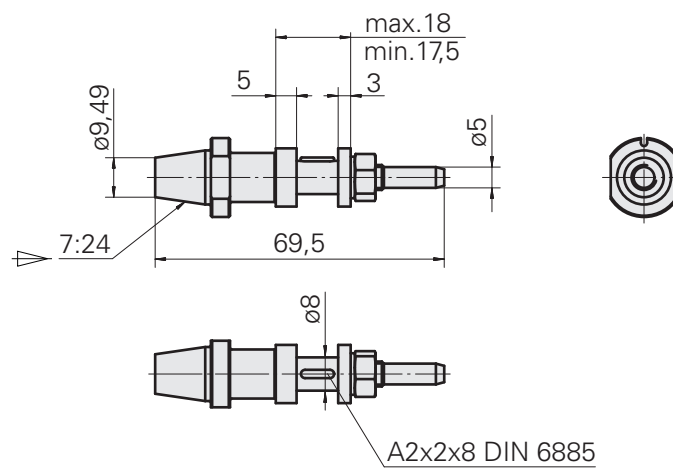
Receptacle arbor,  $\varnothing 8$ 

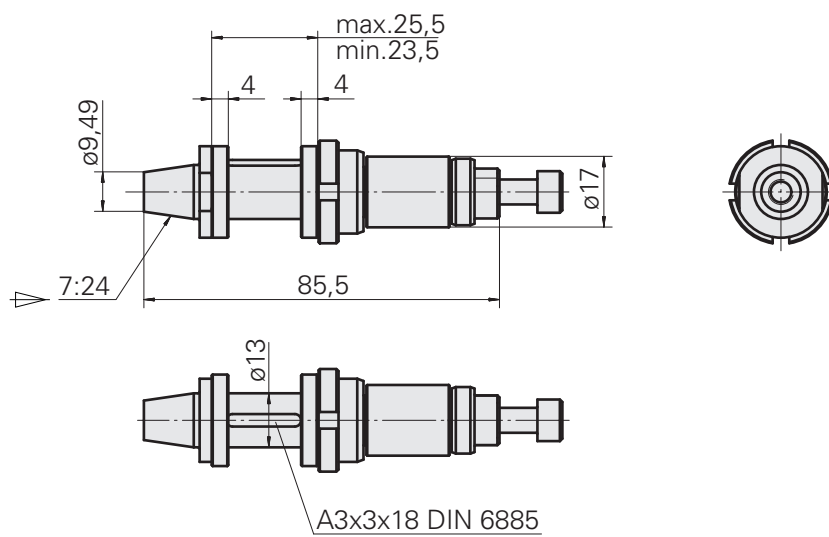
Receptacle arbor,  $\varnothing 13$ 

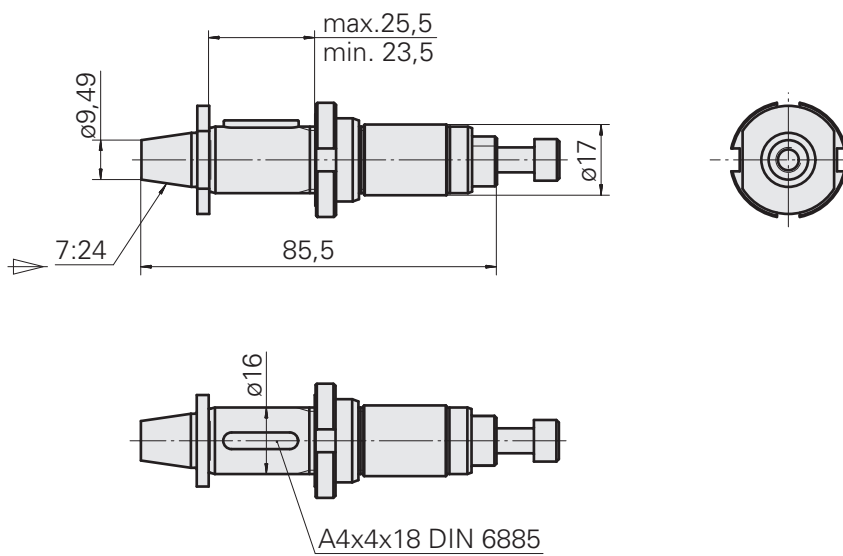
Receptacle arbor,  $\varnothing 16$ 

## Counterbearing

### Accessories

Receptacle arbor  $\varnothing 6$   
W9990350

Receptacle arbor  $\varnothing 8$   
W9990351

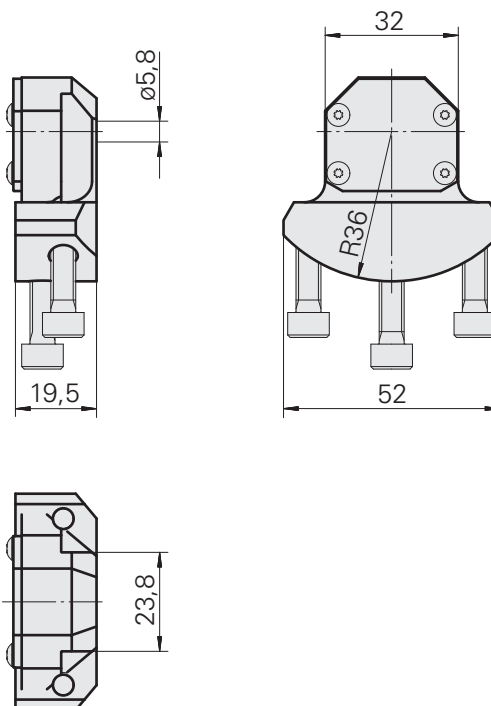

## Counterbearing

### Accessories

Receptacle arbor  $\varnothing 13$   
W9990134

Receptacle arbor  $\varnothing 16$   
W9990135

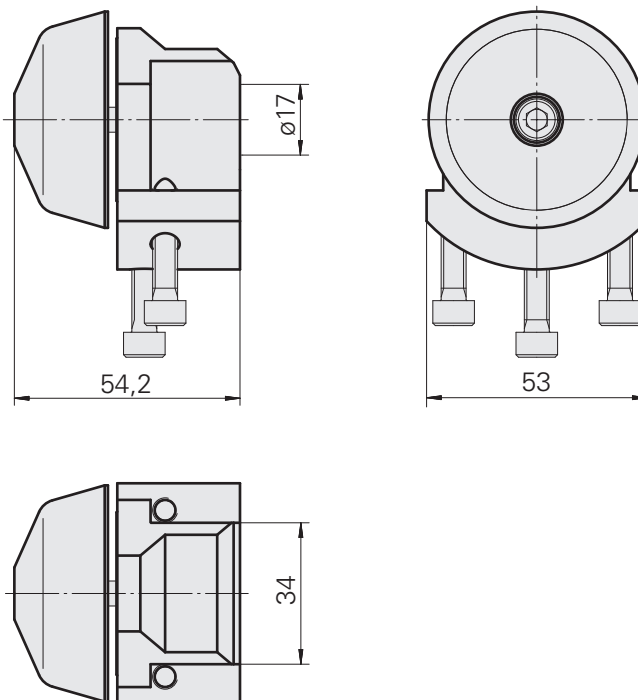

**Broaching tool, internal****Cutting tool**

Slotting tool for hexagon socket

W37606.----

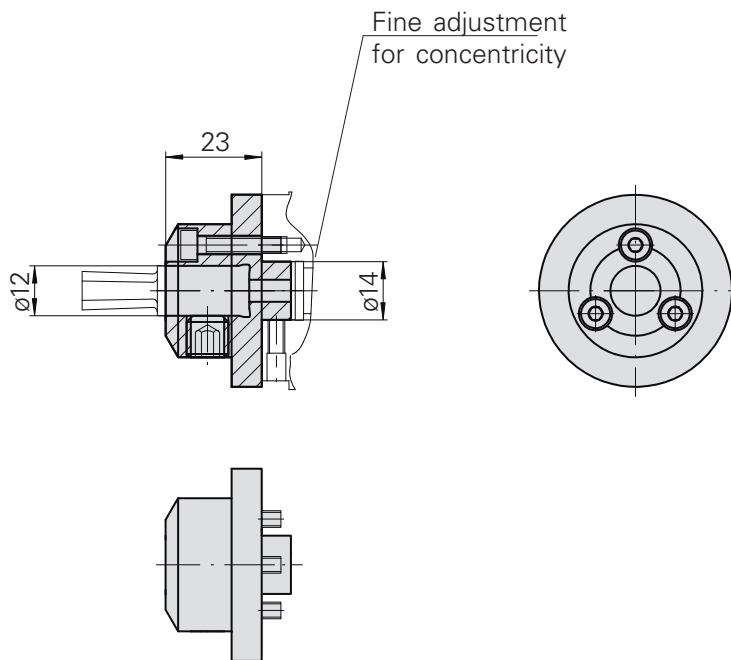



**Broaching tool, external****Cutting tool**

Drawing

AZ4091.00

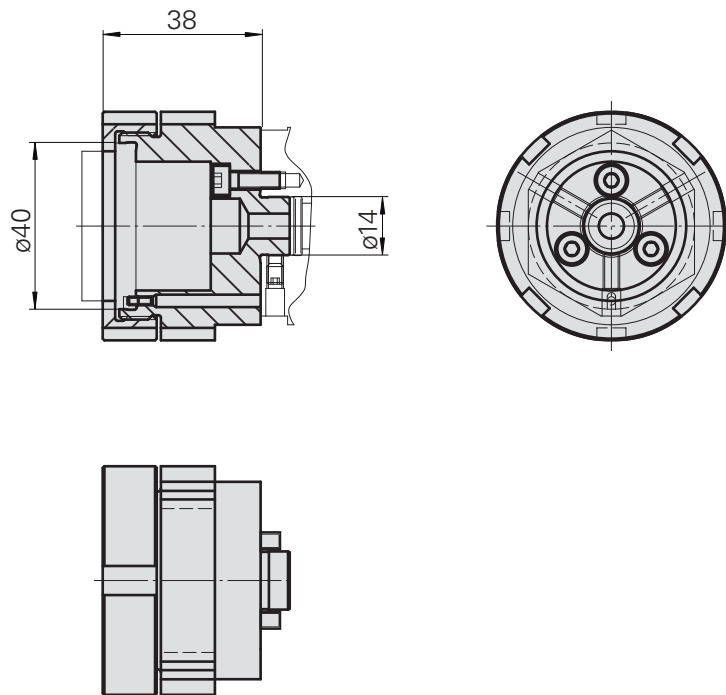

---

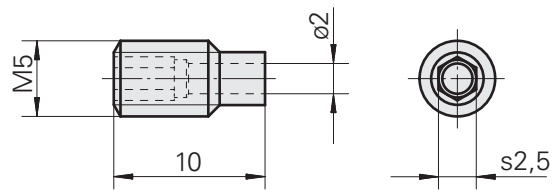
**Adjusting screw**

---

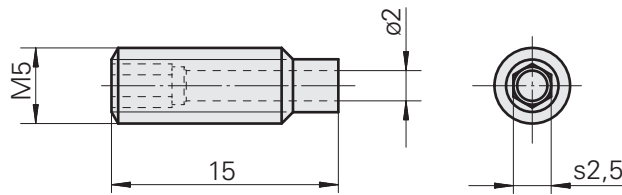
**Adjusting screw**

---

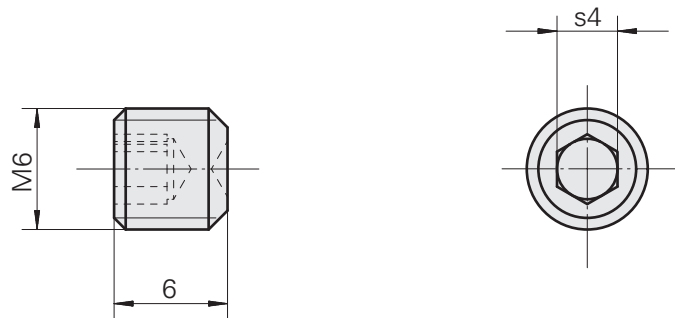
**Clamping screw**

---

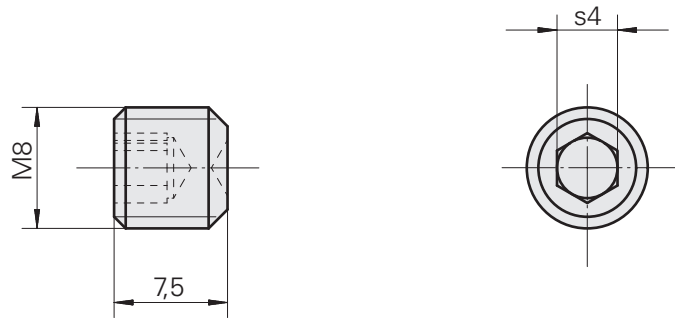
**Clamping screw**

---

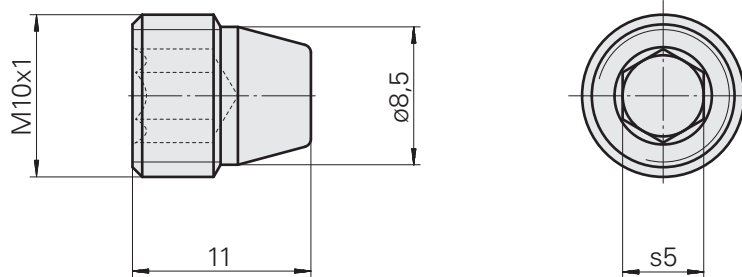
**Set screw**

---

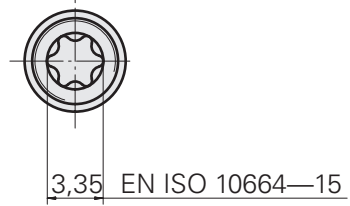
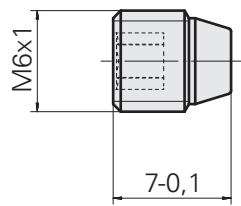
**Set screw**

---

**Set screw**

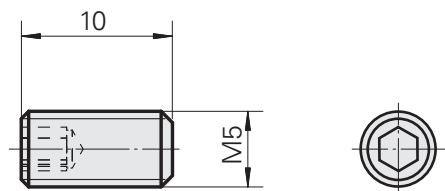



---

**Set screw**

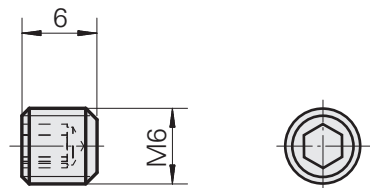

---

**Set screw**

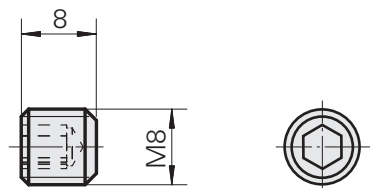

---

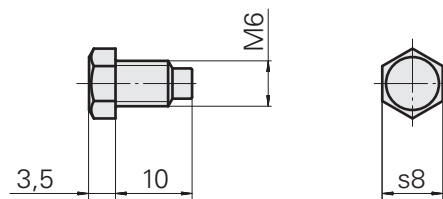
**Clamping screw**

---

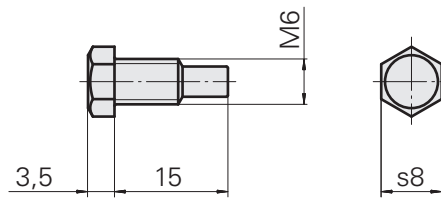
**Clamping screw**

---

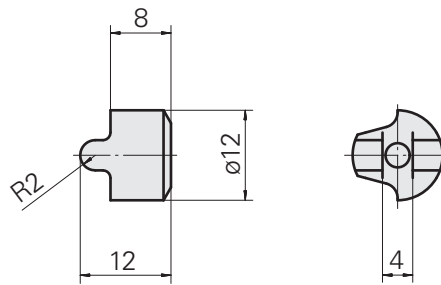
**Fixing pin,  $\varnothing 12$** 

---

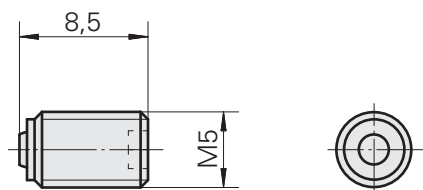
**Ball-ended thrust screw**

## Gasket V70-G1

for receptacle WFB-20-12

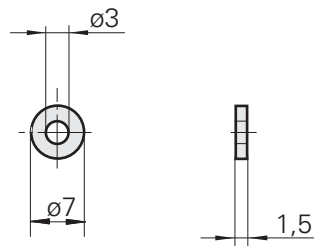

---

**Tool centering device**



## Spindle drive

Meyrat MHF-28 ER8-60

### Accessories

Collet ER8UP 325810

Clamping nut W9990480

Chuck key W9990495

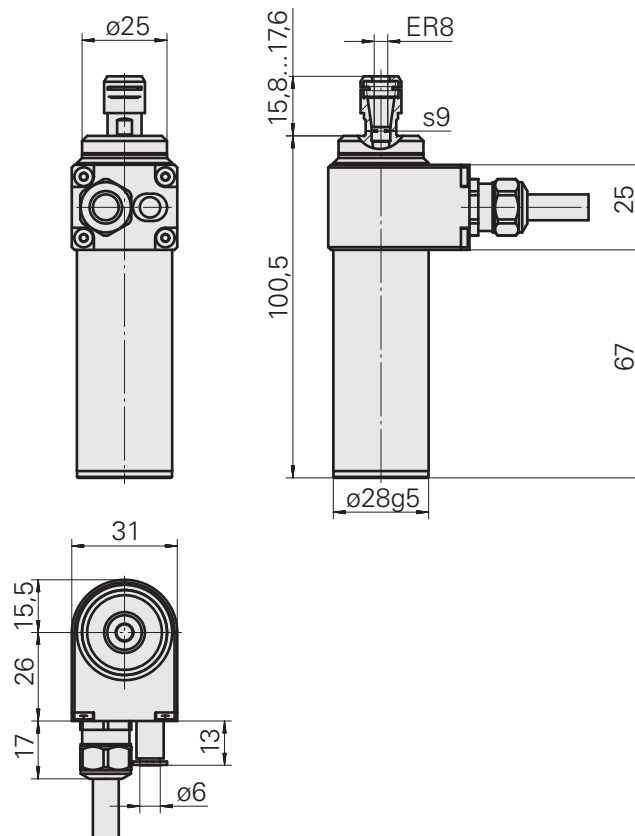

## Bar stop

adjustable, live

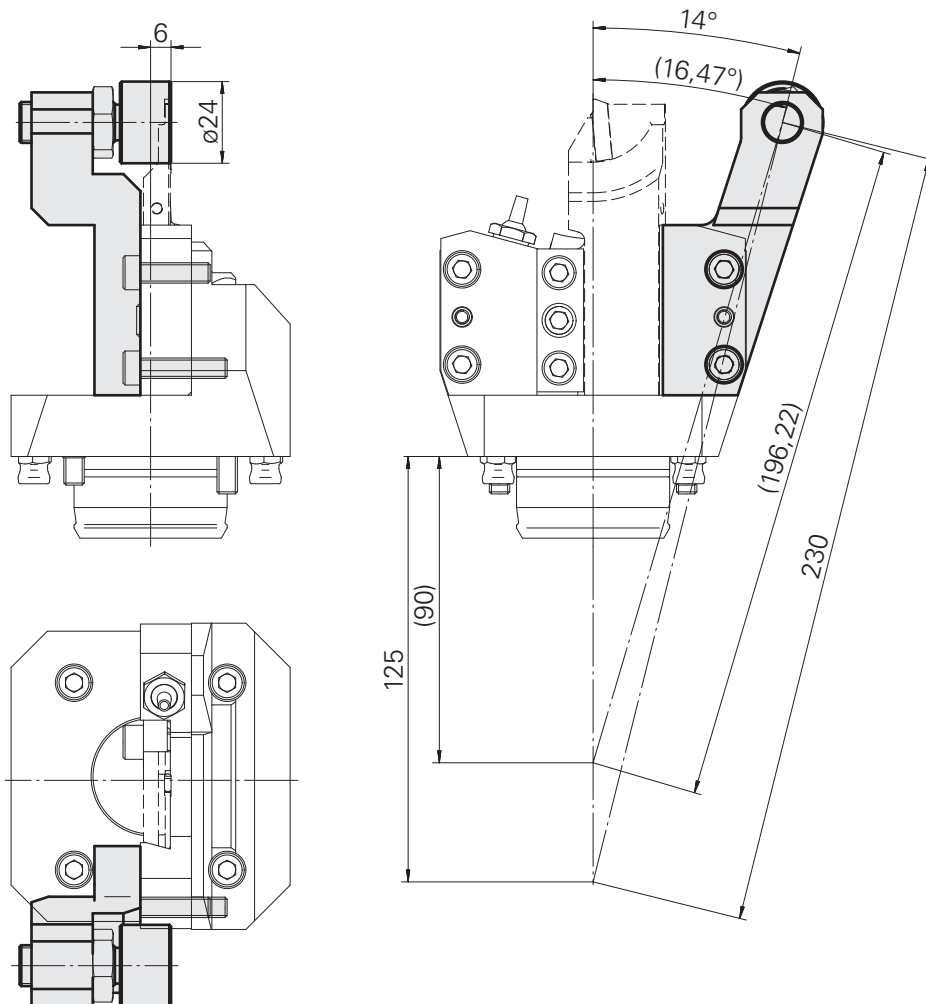

## Mounting

Square 12x12

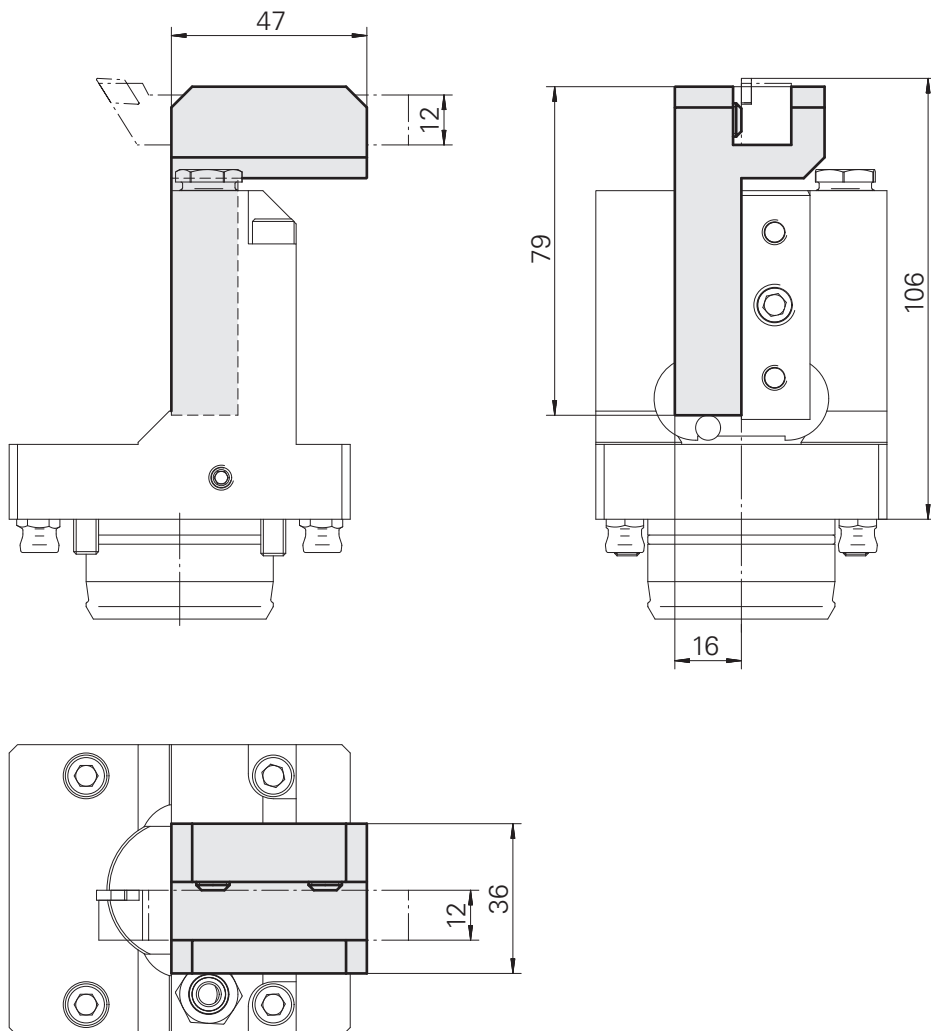

## Adapter plate

suitable only in combination with, e.g., Kelch or Speroni

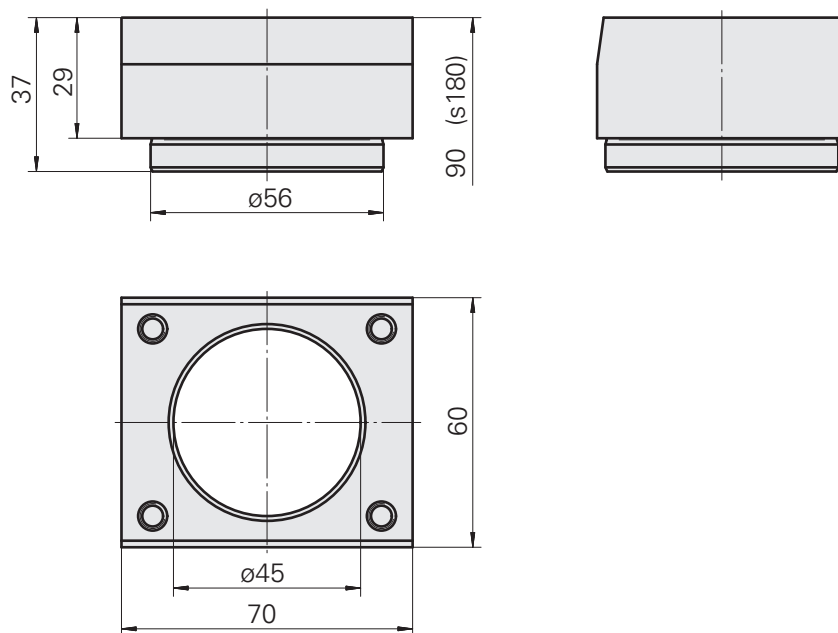

Hose set

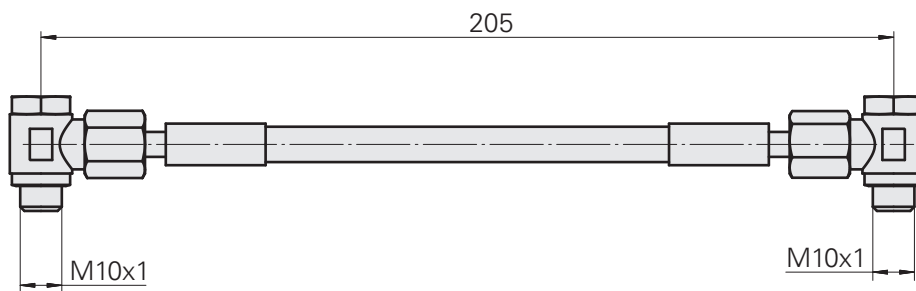

Center

MK2

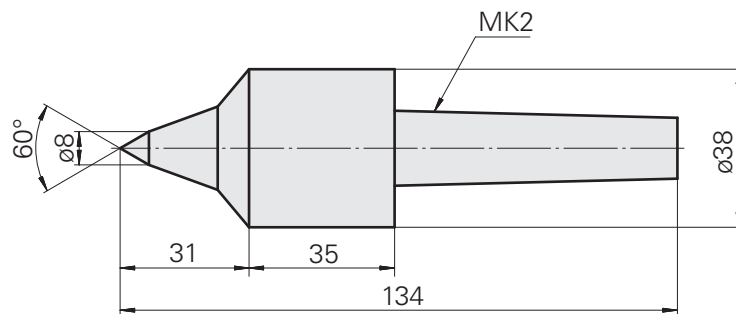

**Set of jaws,  $\varnothing 1 - \varnothing 6$** 

material: POM

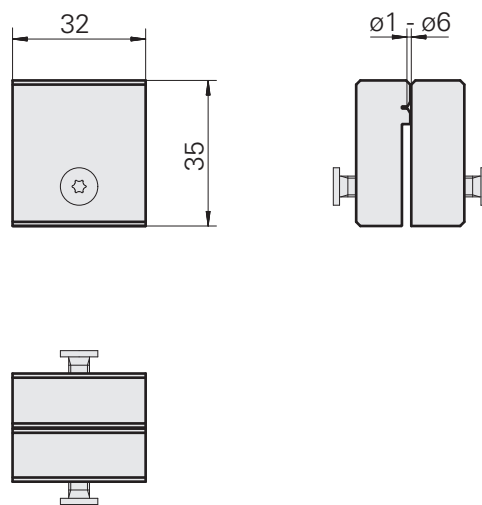

**Set of jaws,  $\varnothing 5 - \varnothing 25$** 

material: POM

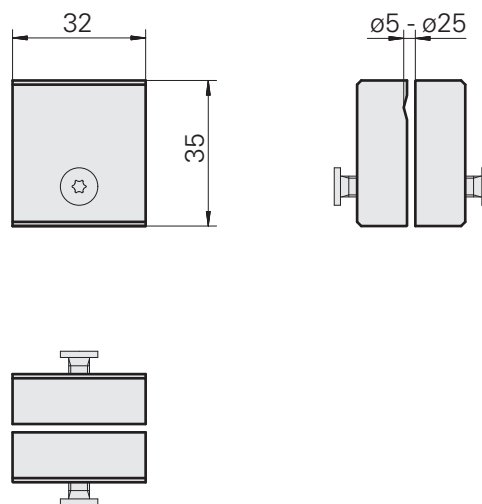



**Set of jaws,  $\varnothing 5 - \varnothing 25$** 

material: 16MnCr5

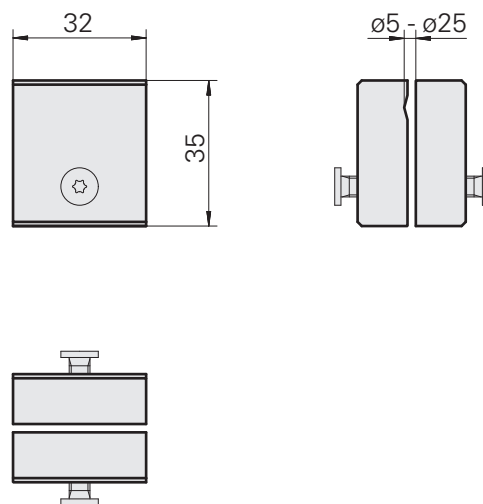



**Product notes**

**TRAUB TNL 18P**

**TRAUB TNL 18-7**

**TRAUB TNL 18-7B**

**TRAUB TNL 18-9**



# Product note

**Writestar RM12/RM20**

## **Disclaimer**

The illustrations in this documents may deviate from the delivered product. We reserve the right to make changes due to errors or based on technical advances.

## **A Word on Copyright**

This document is proprietary and was originally written in German. Its reproduction and distribution in whole or in individual parts without permission of the copyright owner is prohibited and will be prosecuted under criminal or civil law. All rights reserved, including for translation.

© Copyright by INDEX-Werke GmbH & Co. KG Esslingen 2011

© Copyright by TRAUB Drehmaschinen GmbH & Co. KG Reichenbach 2011

Working principle .....	4
Applications .....	4
Setting the marking depth.....	5
Programming notes .....	5
Stylus wear .....	5

## Working principle

- WriteStar is a marking tool that can be used on all CNC machines with an engraving software package.
- Marking labels are permanently created by a combination of material compaction and displacement using a special stylus.
- The tool requires no spindle rotation, cooling lubricant or pressurized air.
- The surface may be wetted with oil or cooling lubricant, but it is not necessary.
- Spindle speeds up to 300rpm are allowed, but they are also not necessary.



## Applications

- WriteStar is suitable for marking surfaces
  - with up to 60HRC hardness.
  - with up to 3mm (RM12) or 5mm (RM20) unevenness.
  - that are non-machined or machined.
- Max. 15-degree slants can be labeled evenly.
- The materials that can be marked include
  - steel
  - cast
  - plastic
  - aluminum
  - titan
- Suitable mountings are turning tool holders with 12/16/20mm or parallel shank mountings with 12 or 20mm diameter.
- The tool mounting clamp screws may contact the WriteStar only through a flat clamping plate, as its housing may be destroyed. The maximum allowed surface load is 500 N/cm<sup>2</sup>.
- For optimal use of WriteStar if space is limited, INDEX TRAUB offers a range of slim drill holders <http://infoshop.index-werke.de>



## Setting the marking depth

- The marking depth depends on the surface hardness; it can be determined by the tool infeed and by the adjusting screw on the back of the tool.
- The more the adjusting screw is turned in, the larger is the force acting on the stylus, resulting in a wider marking line.
- The standard screw-in depth is 6mm (factory setting), while the maximum depth is 15mm.
- Changing the screw-in depth has no effect on the tool length.
- Burrs can be avoided by reducing the infeed/screw-in depth.

## Programming notes

- Many machine tool manufacturers offer subprograms for labeling with numbers, letters, and logos.
- If engraving software has already been used, it can also be applied for marking with WriteStar.
- This requires the following changes
  - Reduce the spindle speed to 0rpm or to the lowest speed.
  - Increase the feed rate to the maximum.
  - Program the tool length such that the special stylus retreats 1 - 2mm (the insertion depth is not equal to the scoring depth).
  - If a burr forms along the marking line or if the marking is too weak, this can be corrected using tool offset.

## Stylus wear

- Experience shows that the stylus, when used under typical conditions and for common material hardnesses, has a life cycle of several years or more than 40km of marking length.
- The stylus is replaced by us.
- Only original styluses ensure the desired marking quality.
- Disassembly of the tool will void the warranty.



# INDEX



## **INDEX-Werke GmbH & Co. KG**

### **Hahn & Tessky**

Plochinger Strasse 92  
D-73730 Esslingen, Germany  
[www.index-werke.de](http://www.index-werke.de)

### **TECHNICAL ADVICE**

Phone +49 (0) 711 3191-9854  
Fax +49 (0) 711 90129-343  
[werkzeughalter@index-werke.de](mailto:werkzeughalter@index-werke.de)

### **SPARE PARTS SALES**

Phone +49 (0) 711 3191-260  
Fax +49 (0) 711 3191-790  
[ersatzteile@index-werke.de](mailto:ersatzteile@index-werke.de)

## **TRAUB-Drehmaschinen**

### **GmbH & Co. KG**

Hauffstrasse 4  
D-73262 Reichenbach, Germany  
[www.traub.de](http://www.traub.de)

### **TECHNICAL ADVICE**

Phone +49 (0) 7153 502-9854  
Fax +49 (0) 711 90129-343  
[werkzeughalter@traub.de](mailto:werkzeughalter@traub.de)

### **SPARE PARTS SALES**

Phone +49 (0) 7153 502-600  
Fax +49 (0) 7153 502-685  
[ersatzteile@traub.de](mailto:ersatzteile@traub.de)

**INDEX**



# Product note

## Hydraulic Gripper

W7040021

## **Disclaimer**

The illustrations in this documents may deviate from the delivered product. We reserve the right to make changes due to errors or based on technical advances.

## **A Word on Copyright**

This document is proprietary and was originally written in German. Its reproduction and distribution in whole or in individual parts without permission of the copyright owner is prohibited and will be prosecuted under criminal or civil law. All rights reserved, including for translation.

© Copyright by INDEX-Werke GmbH & Co. KG Esslingen 2011

© Copyright by TRAUB Drehmaschinen GmbH & Co. KG Reichenbach 2011

## Commissioning of the hydraulic gripper

- The gripper W7040021 may only be installed in Station 1 of the lower tool turret.
- After the gripper has been installed on the tool turret, it must be vented via the vent screw (1).
- To do so, loosen the vent screw (1) and actuate the gripper or pressurize the line.
- Repeat this process until all air has escaped and oil leaks from the line.
- Now retighten the vent screw (1).
- The hydraulic gripper is now ready to use.

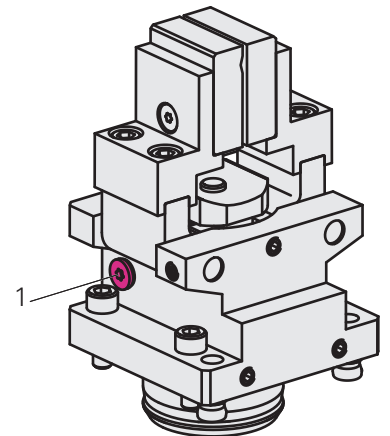

## Gripping from the counter spindle

- After the gripper W7040021 has gripped the workpiece from the counter spindle, move the tool turret in the Y direction.
- Here is to detect whether the workpiece is still in the counter spindle or not.
- The max. part length that can be removed is 180 mm when discharging to the part conveyor belt in the work area.
- See the programming manual for more information programming.

### Gripping position

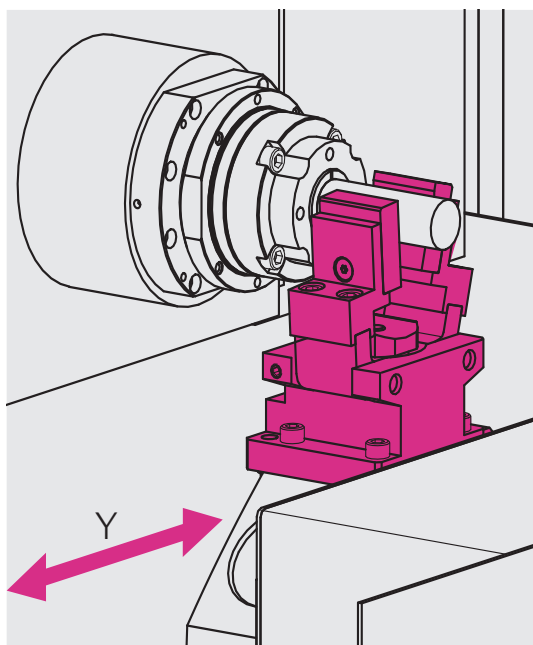

### Depositing position

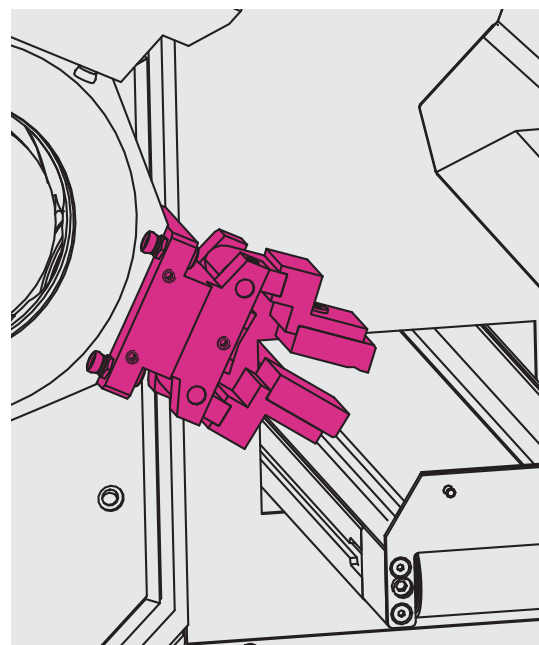

# INDEX

**INDEX-Werke GmbH & Co. KG****Hahn & Tessky**

Plochinger Strasse 92  
D-73730 Esslingen, Germany  
[www.index-werke.de](http://www.index-werke.de)

**TRAUB-Drehmaschinen****GmbH & Co. KG**

Hauffstrasse 4  
D-73262 Reichenbach, Germany  
[www.traub.de](http://www.traub.de)

**TECHNICAL ADVICE**

Phone +49 (0) 711 3191-9854  
Fax +49 (0) 711 90129-343  
[werkzeughalter@index-werke.de](mailto:werkzeughalter@index-werke.de)

**TECHNICAL ADVICE**

Phone +49 (0) 7153 502-9854  
Fax +49 (0) 711 90129-343  
[werkzeughalter@traub.de](mailto:werkzeughalter@traub.de)

**SPARE PARTS SALES**

Phone +49 (0) 711 3191-260  
Fax +49 (0) 711 3191-790  
[ersatzteile@index-werke.de](mailto:ersatzteile@index-werke.de)

**SPARE PARTS SALES**

Phone +49 (0) 7153 502-600  
Fax +49 (0) 7153 502-685  
[ersatzteile@traub.de](mailto:ersatzteile@traub.de)

# Product note

## **WFB interface**

Mounting, cleaning and care, tightening torques

## **Disclaimer**

The illustrations in this documents may deviate from the delivered product. We reserve the right to make changes due to errors or based on technical advances.

## **A Word on Copyright**

This document is proprietary and was originally written in German. Its reproduction and distribution in whole or in individual parts without permission of the copyright owner is prohibited and will be prosecuted under criminal or civil law. All rights reserved, including for translation.

© Copyright by INDEX-Werke GmbH & Co. KG Esslingen 2012

© Copyright by TRAUB Drehmaschinen GmbH & Co. KG Reichenbach 2012



## WFB interface

Mounting, cleaning and care, tightening torques

### Mounting

- Tighten threaded taper pin (1) by loosening and retightening it 1 or 2 times. This results in optimum positioning of the components.
- Now also tighten the threaded taper pin (2) (in the same way as above).
- For the torques, please see the table below.

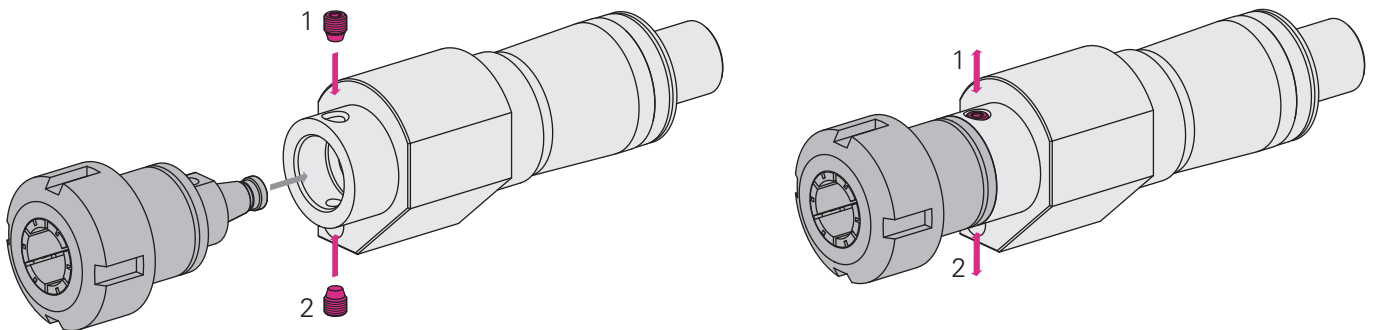

### Cleaning and Care

- The surfaces of the faces, taper bore and tapers must be cleaned and covered with an oil lubricating film.
- For best fastening results and to ensure that the threaded taper pins can easily be loosened, it is recommended to apply Molykote 1000 or a similar hot screw compound to the threaded taper pins.

### Tightening torques

Tightening torques		
Size	Threaded Taper Pin	Tightening Torque
WFB 20-12	M6x1	4 Nm
WFB 24-16	M8x1	10 Nm
WFB 32-20	M10x1	20 Nm
WFB 40-25	M12x1	25 Nm
WFB 50-32	M14x1	30 Nm

Tightening torques When Using Mandrel Gauges		
Size	Threaded Taper Pin	Tightening Torque
WFB 20-12	M6x1	5 Nm
WFB 24-16	M8x1	5 Nm
WFB 32-20	M10x1	10 Nm
WFB 40-25	M12x1	10 Nm
WFB 50-32	M14x1	15 Nm

# INDEX



## **INDEX-Werke GmbH & Co. KG**

### **Hahn & Tessky**

Plochinger Strasse 92  
D-73730 Esslingen, Germany  
[www.index-werke.de](http://www.index-werke.de)

## **TRAUB-Drehmaschinen**

### **GmbH & Co. KG**

Hauffstrasse 4  
D-73262 Reichenbach, Germany  
[www.traub.de](http://www.traub.de)

### **TECHNICAL ADVICE**

Phone +49 (0) 711 3191-9854  
Fax +49 (0) 711 90129-343  
[werkzeughalter@index-werke.de](mailto:werkzeughalter@index-werke.de)

### **TECHNICAL ADVICE**

Phone +49 (0) 7153 502-9854  
Fax +49 (0) 711 90129-343  
[werkzeughalter@traub.de](mailto:werkzeughalter@traub.de)

### **SPARE PARTS SALES**

Phone +49 (0) 711 3191-260  
Fax +49 (0) 711 3191-790  
[ersatzteile@index-werke.de](mailto:ersatzteile@index-werke.de)

### **SPARE PARTS SALES**

Phone +49 (0) 7153 502-600  
Fax +49 (0) 7153 502-685  
[ersatzteile@traub.de](mailto:ersatzteile@traub.de)

**INDEX**



# Product note

## **INDEX TRAUB CAPTO**

Live tools

## **Disclaimer**

The illustrations in this documents may deviate from the delivered product. We reserve the right to make changes due to errors or based on technical advances.

## **A Word on Copyright**

This document is proprietary and was originally written in German. Its reproduction and distribution in whole or in individual parts without permission of the copyright owner is prohibited and will be prosecuted under criminal or civil law. All rights reserved, including for translation.

© Copyright by INDEX-Werke GmbH & Co. KG Esslingen 2012

© Copyright by TRAUB Drehmaschinen GmbH & Co. KG Reichenbach 2012

# INDEX TRAUB CAPTO

Live tools

## Capto system

A feature of the tool interface and contact surface according to DIN ISO 26623-1 is the polygonal hollow shaft taper that allows safe and backlash-free fixing in position and transmission of high torques without additional elements such as drive slots.

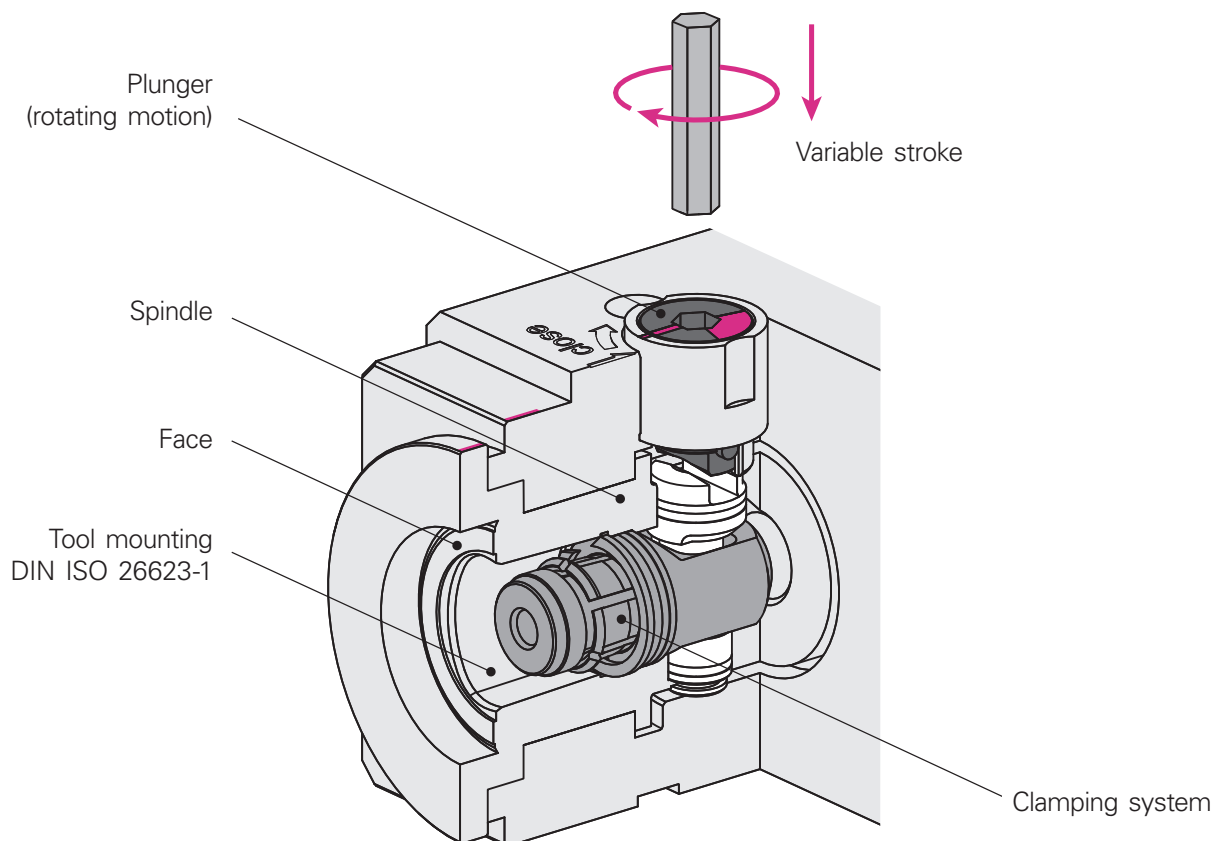

## Technical highlights

- Very compact installation space
- High power gain and compact power flow by transmission in the clamping system
- Automatic tool ejection upon release by the clamping system
- Sealed system for central coolant supply
- Separate blow-out possible of the clamping system



The prescribed actuating stroke of the plunger must be achieved during release and clamping.

The plunger must be in raised position before the tool drive can be used.

With internal coolant supply, filtering the coolant to at least 50 microns must be ensured.

The tool holder must not be operated without clamping the tool adapter.

The tool adapter must only be used in the base position.

# INDEX TRAUB CAPTO

Live tools

## Cleaning the face contact surface

- Ensure absolute cleanliness when changing the tool.
- All functional surfaces must be cleaned before the clamping process.

## Adjustment

- Before the clamping system can be actuated, the markings on the housing and the spindle must be aligned to each other.
- To do so, rotate the spindle until it reaches the desired position.

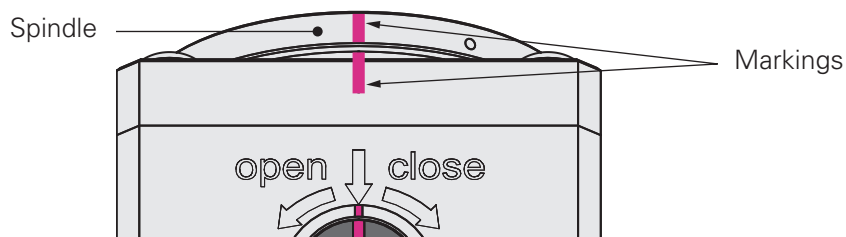

## Base position

- Delivery condition
- If the actuating stroke cannot be executed completely, the plunger must be rotated until this is possible.

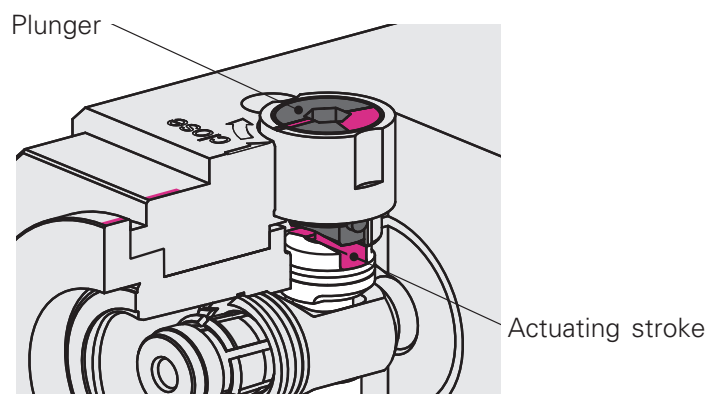

# INDEX TRAUB CAPTO

Live tools

## Bringing into base position

- For this, the spring of the plunger must be brought in the position of the clamp groove.

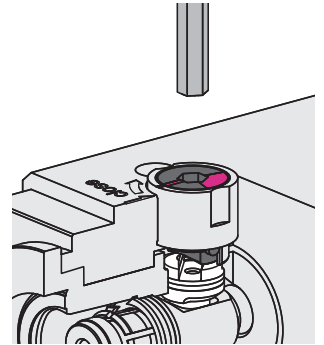

- Slightly depress the tool key.
- The actuating stroke cannot fully be executed.
- Rotate until the spring of the plunger can engage into the groove of the clamp.

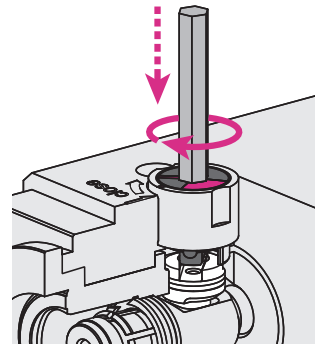

- In the depressed position, the spring can engage into the groove of the clamp.
- The actuating stroke can fully be executed.

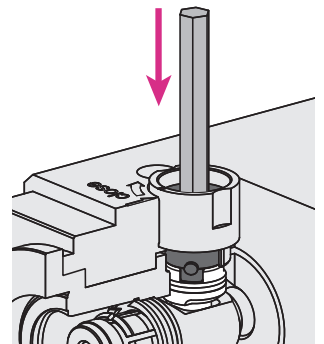

- With the tool key depressed, rotate it counterclockwise until the base position is reached.

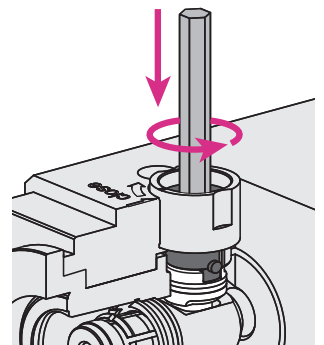

# INDEX TRAUB CAPTO

Live tools

## Inserting the tool adapter in base position

- When delivered, the tool clamp is open.
- The clamping actuator is in the base position.
- The tool adapter can be inserted in this position.
- An integrated latching function locks the tool adapter in the spindle.

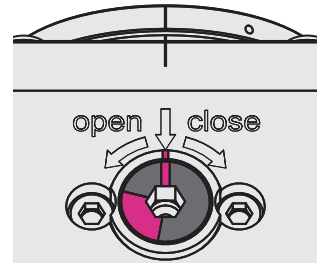

## Clamping the tool adapter

- By pushing the plunger, it engages in the clamping mechanism, and by a subsequent rotation in the clockwise direction, the clamping mechanism is actuated.
- Make sure that the prescribed actuating stroke is achieved. For this, the spindle must be aligned as described in Section "Adjustment".
- For the torque and actuating stroke, see the Technical Data table (page 8).

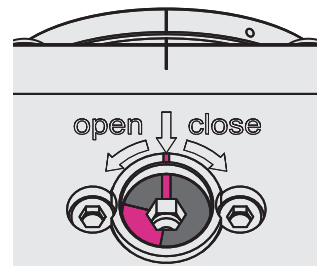

## Self-locking range

- From a rotation of 75°, the clamp enters the self-locking range and the tool adapter is clamped.
- With increasing angle of rotation, the clamping force of the tool adapter is increased.

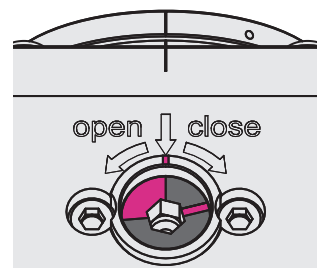

## Maximum torque

- The specified maximum torques for maximum clamping force are achieved from a rotation angle of approximately 105°.
- For the forces and torques, see the Technical Data table (page 8).

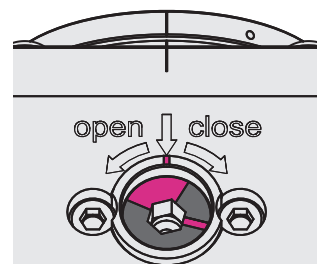



# INDEX TRAUB CAPTO

Live tools

## Releasing the tool adapter

- For this, the spindle must be aligned as described in Section "Adjustment".
- To release the tool adapter, depress the plunger again and rotate it counterclockwise to the base position.
- Make sure that the prescribed actuating stroke is achieved.
  
- If the actuating stroke cannot be fully executed, proceed as described in Section "Bringing into base position".
  
- Ejecting the tool adapter briefly requires an increased release torque shortly before reaching the end position.
- To release the adapter, see the specification in the Technical Data table (page 8).

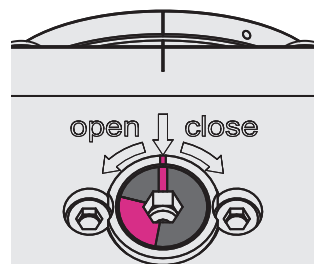
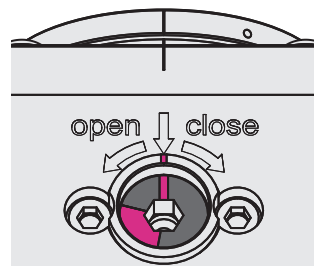
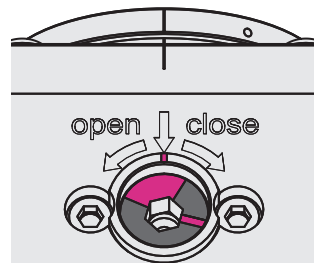

# INDEX TRAUB CAPTO

Live tools

## Technical data

	<b>C3</b>	<b>C4</b>	<b>C5</b>
Latching function	20 N	30 N	40 N
Force max.	16 kN	22 kN	27 kN
Torque max.	35 Nm	50 Nm	70 Nm
Release force	8 kN	10 kN	13 kN
Release torque	17 Nm	25 Nm	35 Nm
Actuating stroke	4 mm	4 mm	4.5 mm

## Tightening torque when using mandrel gauges

Size	Actuation	Concentricity	Torque
C3	SW 6	0.025 mm	18 Nm
C4	SW 8	0.025 mm	25 Nm
C5	SW 10	0.025 mm	35 Nm

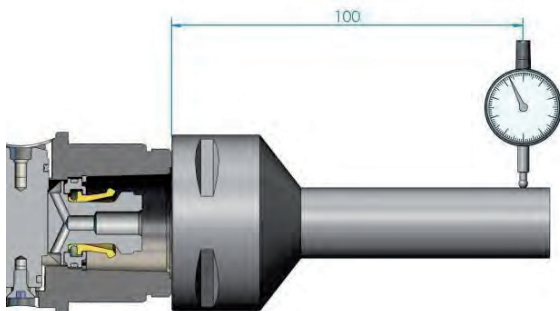

# INDEX TRAUB CAPTO

Live tools

## Charts

The German Industrial Standard (DIN) defines for this system a minimum tensile force, which is achieved by the torques shown in the chart.

In the rotating range, a torque according to ISO 26623-2 is required.

If high cutting forces occur in the static range, the maximum tensile forces at the maximum torque can be achieved as indicated in the charts.

**Force vs. torque chart C3**

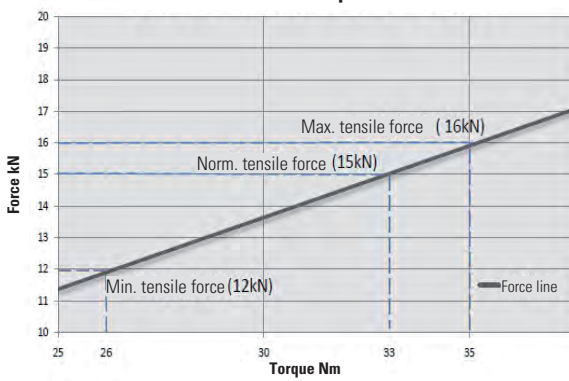

**Force vs. torque chart C4**

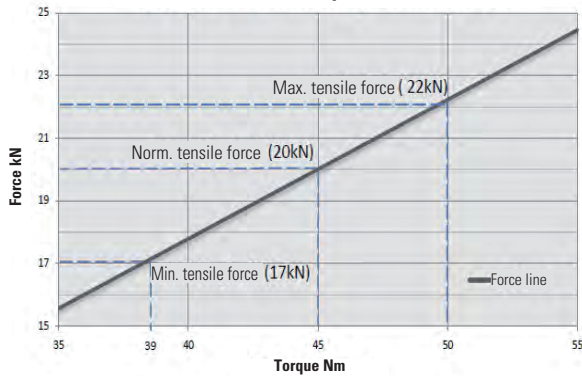

**Force vs. torque chart C5**

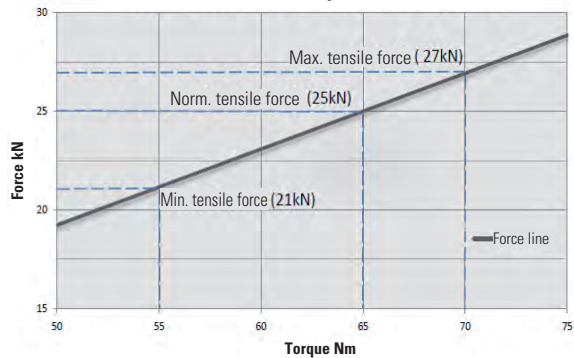

**Product note**

INDEX TRAUB CAPTO, live tools  
W9800010EN-16.05.2012





# INDEX

**INDEX-Werke GmbH & Co. KG****Hahn & Tessky**

Plochinger Strasse 92  
D-73730 Esslingen, Germany  
[www.index-werke.de](http://www.index-werke.de)

**TRAUB-Drehmaschinen****GmbH & Co. KG**

Hauffstrasse 4  
D-73262 Reichenbach, Germany  
[www.traub.de](http://www.traub.de)

**TECHNICAL ADVICE**

Phone +49 (0) 711 3191-9854  
Fax +49 (0) 711 90129-343  
[werkzeughalter@index-werke.de](mailto:werkzeughalter@index-werke.de)

**TECHNICAL ADVICE**

Phone +49 (0) 7153 502-9854  
Fax +49 (0) 711 90129-343  
[werkzeughalter@traub.de](mailto:werkzeughalter@traub.de)

**SPARE PARTS SALES**

Phone +49 (0) 711 3191-600  
Fax +49 (0) 711 3191-790  
[ersatzteile@index-werke.de](mailto:ersatzteile@index-werke.de)

**SPARE PARTS SALES**

Phone +49 (0) 7153 502-600  
Fax +49 (0) 7153 502-685  
[ersatzteile@traub.de](mailto:ersatzteile@traub.de)

**INDEX**



# Product note

## **INDEX TRAUB CAPTO**

Stationary tools

## **Disclaimer**

The illustrations in this documents may deviate from the delivered product. We reserve the right to make changes due to errors or based on technical advances.

## **A Word on Copyright**

This document is proprietary and was originally written in German. Its reproduction and distribution in whole or in individual parts without permission of the copyright owner is prohibited and will be prosecuted under criminal or civil law. All rights reserved, including for translation.

© Copyright by INDEX-Werke GmbH & Co. KG Esslingen 2012

© Copyright by TRAUB Drehmaschinen GmbH & Co. KG Reichenbach 2012



# INDEX TRAUB CAPTO

Stationary tools

## Capto system

A feature of the tool interface and contact surface according to DIN ISO 26623-1 is the polygonal hollow shaft taper that allows safe and backlash-free fixing in position and transmission of high torques without additional elements such as drive slots.

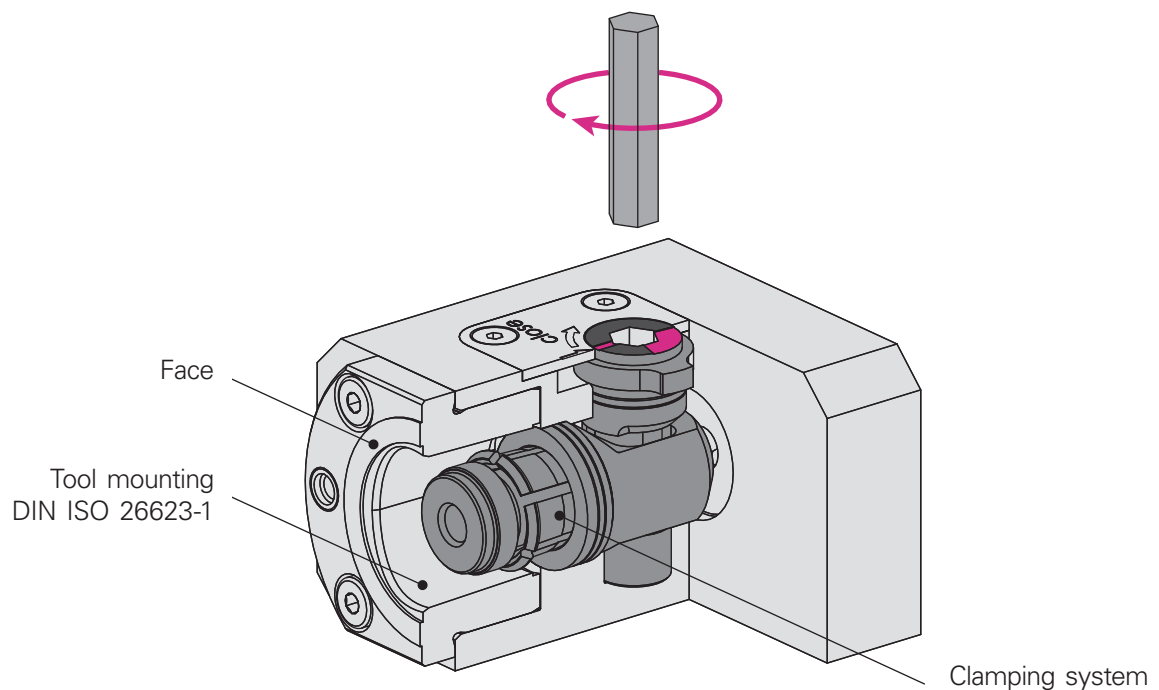

## Technical highlights

- Very compact installation space
- High power gain and compact power flow by transmission in the clamping system
- Automatic tool ejection upon release by the clamping system
- Sealed system for central coolant supply
- Separate blow-out possible of the clamping system



With internal coolant supply, filtering the coolant to at least 50 microns must be ensured.

The tool holder must not be operated without clamping the tool adapter.

The tool adapter must only be used in the base position.

# INDEX TRAUB CAPTO

Stationary tools

## Cleaning the face contact surface

- Ensure absolute cleanliness when changing the tool.
- All functional surfaces must be cleaned before the clamping process.

## Inserting the tool adapter in base position

- When delivered, the tool clamp is open.
- The clamping actuator is in the base position.
- The tool adapter can be inserted in this position.
- An integrated latching function locks the tool adapter in the tool holder.

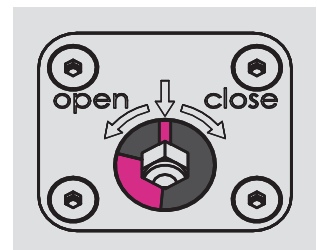

## Clamping the tool adapter

- The clamping mechanism is actuated by a rotation in the clockwise direction.
- For the torque, see the Technical Data table.

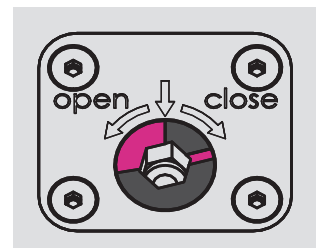

### Self-locking range

- From a rotation of 75°, the clamp enters the self-locking range and the tool adapter is clamped.
- With increasing angle of rotation, the clamping force is increased.

### Maximum torque

- The specified maximum torques for maximum clamping force are achieved from a rotation angle of approximately 105°.
- For the forces and torques, see the Technical Data table (page 6).

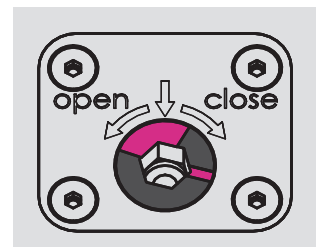

# INDEX TRAUB CAPTO

Stationary tools

## Releasing the tool adapter

- To release the tool adapter, rotate it counterclockwise to the base position.

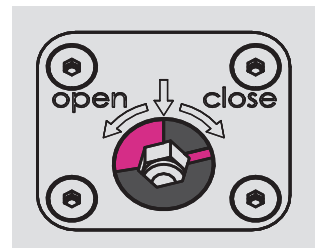
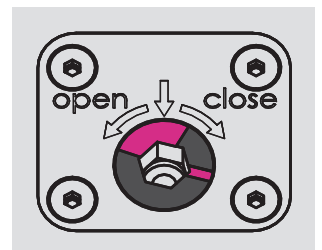

- Ejecting the tool adapter briefly requires an increased release torque shortly before reaching the base position.
- To release the adapter, see the specification in the Technical Data table (page 6).

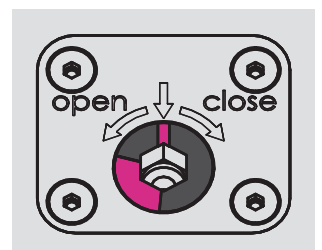

# INDEX TRAUB CAPTO

Stationary tools

## Technical data

	<b>C3</b>	<b>C4</b>	<b>C5</b>
Latching function	20 N	30 N	40 N
Force max.	16 kN	22 kN	27 kN
Torque max.	35 Nm	50 Nm	70 Nm
Release force	8 kN	10 kN	13 kN
Release torque	17 Nm	25 Nm	35 Nm

# INDEX TRAUB CAPTO

Stationary tools

## Charts

The German Industrial Standard (DIN) defines for this system a minimum tensile force, which is achieved by the torques shown in the chart.

In the rotating range, a torque according to ISO 26623-2 is required.

If high cutting forces occur in the static range, the maximum tensile forces at the maximum torque can be achieved as indicated in the charts.

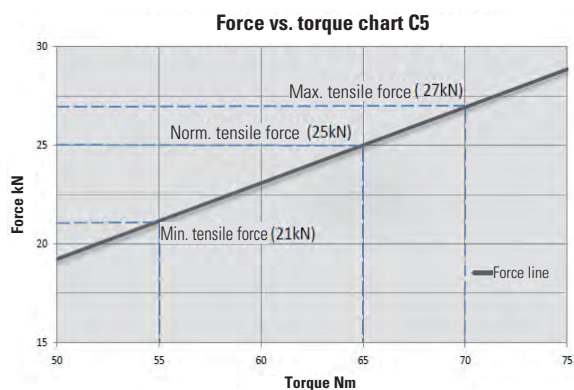
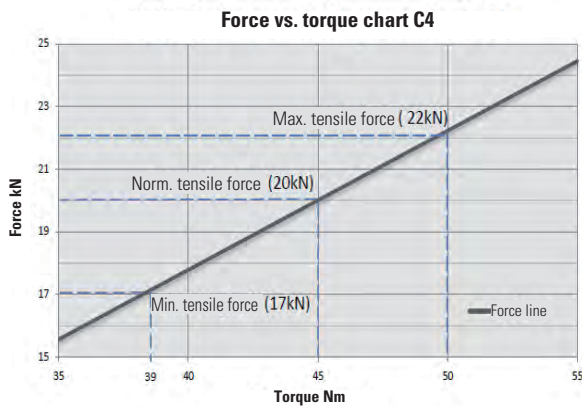
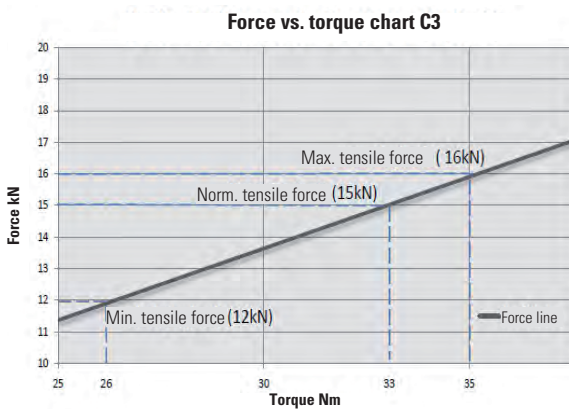

**Product note**

INDEX TRAUB CAPTO, stationary tools  
W9800011EN-11.04.2012

# INDEX



## **INDEX-Werke GmbH & Co. KG**

### **Hahn & Tessky**

Plochinger Strasse 92  
D-73730 Esslingen, Germany  
[www.index-werke.de](http://www.index-werke.de)

### **TECHNICAL ADVICE**

Phone +49 (0) 711 3191-9854  
Fax +49 (0) 711 90129-343  
[werkzeughalter@index-werke.de](mailto:werkzeughalter@index-werke.de)

### **SPARE PARTS SALES**

Phone +49 (0) 711 3191-600  
Fax +49 (0) 711 3191-790  
[ersatzteile@index-werke.de](mailto:ersatzteile@index-werke.de)

## **TRAUB-Drehmaschinen**

### **GmbH & Co. KG**

Hauffstrasse 4  
D-73262 Reichenbach, Germany  
[www.traub.de](http://www.traub.de)

### **TECHNICAL ADVICE**

Phone +49 (0) 7153 502-9854  
Fax +49 (0) 711 90129-343  
[werkzeughalter@traub.de](mailto:werkzeughalter@traub.de)

### **SPARE PARTS SALES**

Phone +49 (0) 7153 502-600  
Fax +49 (0) 7153 502-685  
[ersatzteile@traub.de](mailto:ersatzteile@traub.de)

# Product note

## **Gear cutting unit, adjustable angle**

Face contact cupped

## **Disclaimer**

The illustrations in this documents may deviate from the delivered product. We reserve the right to make changes due to errors or based on technical advances.

## **A word on copyright**

This document is proprietary and was originally written in German. Its reproduction and distribution in whole or in individual parts without permission of the copyright owner is prohibited and will be prosecuted under criminal or civil law. All rights reserved, including for translation.

© Copyright by INDEX-Werke GmbH & Co. KG Esslingen 2013

© Copyright by TRAUB Drehmaschinen GmbH & Co. KG Reichenbach 2013



## Gear cutting unit, adjustable angle

Face contact cupped

### Presetting

- Presetting is done outside the tool holder, to achieve a play-free fit in the bearings
- Assemble ring (A), taper (B) and clamping sleeves (C)
- Use cylinder head screw (D) to tighten the mounting arbor (E)
- Adjust the required outside diameter  $17\text{mm}+0.004$  by grinding the ring (A)
- Disassemble again for installation in the gear cutting unit

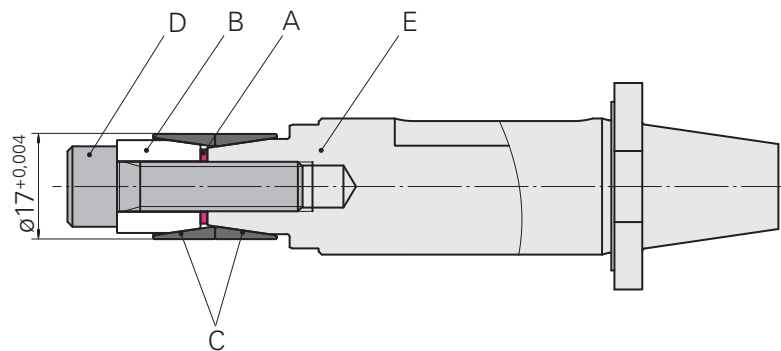

#### Product note

Gear cutting unit, adjustable angle - Face contact cupped  
W9800013EN-13.09.2013

# Gear cutting unit, adjustable angle

Face contact cupped

## Installation

- Tighten mounting arbor (E) and inserted gear cutter (Y) with cylinder head screw (Z) to 14 Nm
- Assemble cover (F) and housing (G)
- Insert into gear cutting unit (H)
- Observe face contact (I) of the housing (G) during installation
- Tighten cylinder head screw (D)
- Tighten cylinder head screws (J)

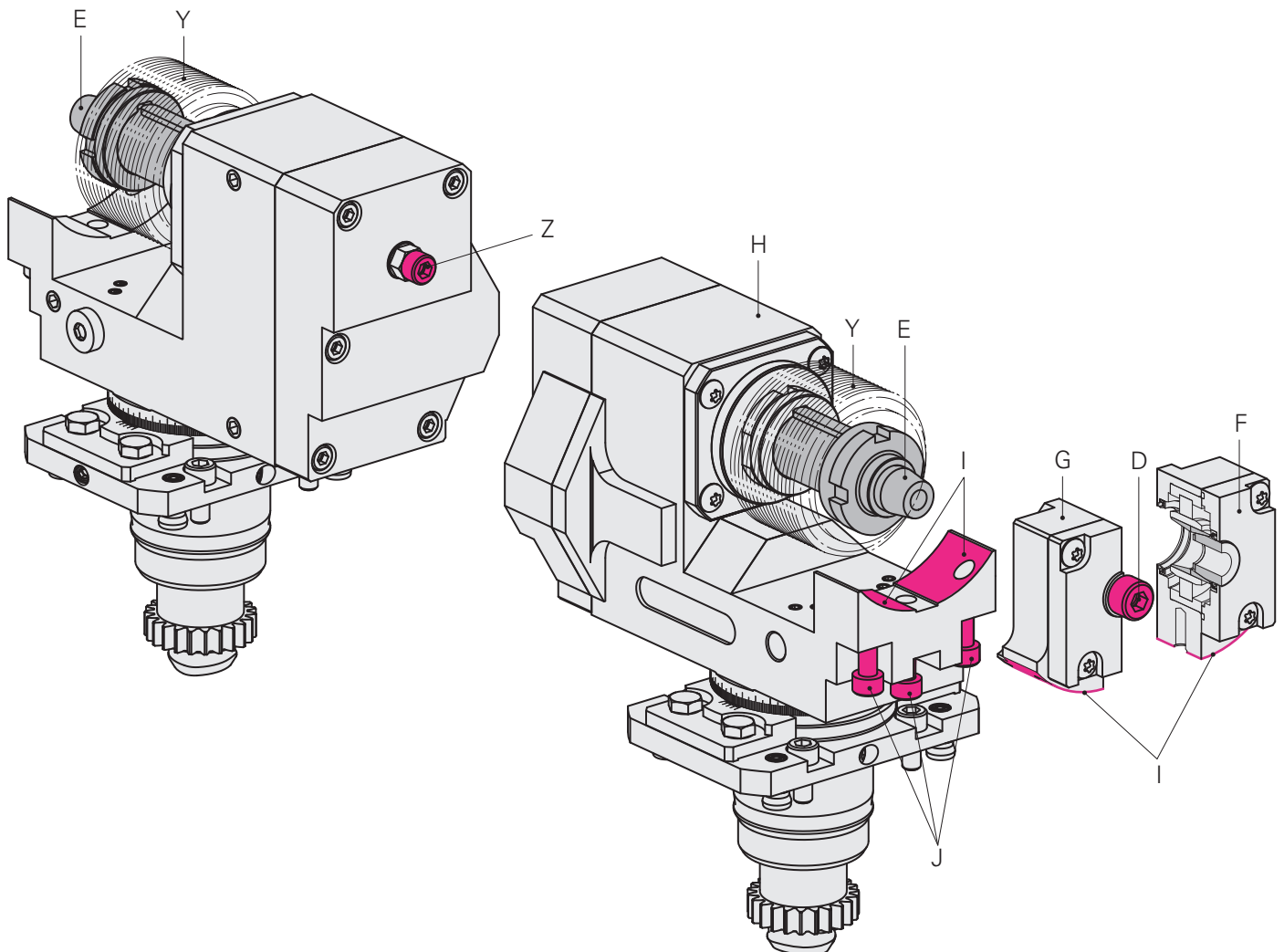

## Gear cutting unit, adjustable angle

Face contact cupped

### Angle adjustment

- Adjust the angle and speed as instructed by the manufacturer of the gear cutters
- Angular scale (W) is used for coarse adjustment
- Angle is adjusted when installed in the machine on the ground measuring surface (M)

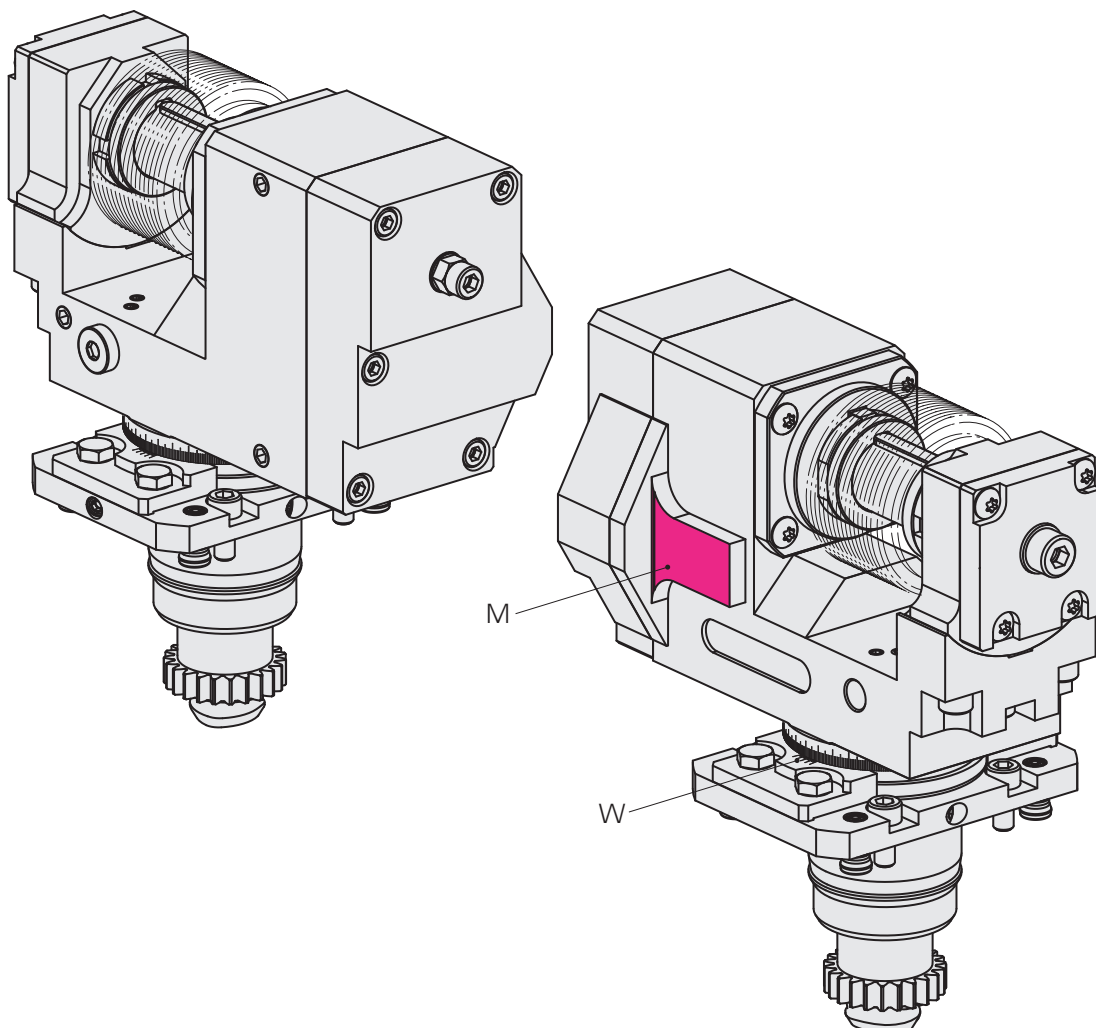

**Product note**

Gear cutting unit, adjustable angle - Face contact cupped  
W9800013EN-13.09.2013



**Product note**

Gear cutting unit, adjustable angle - Face contact cupped  
W9800013EN-13.09.2013

# INDEX

**INDEX-Werke GmbH & Co. KG****Hahn & Tessky**

Plochinger Strasse 92  
D-73730 Esslingen, Germany  
[www.index-werke.de](http://www.index-werke.de)

**TRAUB-Drehmaschinen****GmbH & Co. KG**

Hauffstrasse 4  
D-73262 Reichenbach, Germany  
[www.traub.de](http://www.traub.de)

**TECHNICAL ADVICE**

Phone +49 (0) 711 3191-9854  
Fax +49 (0) 711 90129-343  
[werkzeughalter@index-werke.de](mailto:werkzeughalter@index-werke.de)

**TECHNICAL ADVICE**

Phone +49 (0) 7153 502-9854  
Fax +49 (0) 711 90129-343  
[werkzeughalter@traub.de](mailto:werkzeughalter@traub.de)

**SPARE PARTS SALES**

Phone +49 (0) 711 3191-600  
Fax +49 (0) 711 3191-790  
[ersatzteile@index-werke.de](mailto:ersatzteile@index-werke.de)

**SPARE PARTS SALES**

Phone +49 (0) 7153 502-600  
Fax +49 (0) 7153 502-685  
[ersatzteile@traub.de](mailto:ersatzteile@traub.de)

# Product note

## Cooling lubricant supply

External cooling lubricant supply

Internal cooling lubricant supply with internal transfer, set screw

Normal pressure up to 80 bar

High pressure above 80 bar

Pressure distribution

## **Disclaimer**

The illustrations in this documents may deviate from the delivered product. We reserve the right to make changes due to errors or based on technical advances.

## **A word on copyright**

This document is proprietary and was originally written in German. Its reproduction and distribution in whole or in individual parts without permission of the copyright owner is prohibited and will be prosecuted under criminal or civil law. All rights reserved, including for translation.

© Copyright by INDEX-Werke GmbH & Co. KG Esslingen 2014

© Copyright by TRAUB Drehmaschinen GmbH & Co. KG Reichenbach 2014



**External cooling lubricant supply**

Delivery condition..... 5

**Internal cooling lubricant supply**

Normal pressure up to 80 bar..... 6

High pressure above 80 bar ..... 7

Pressure distribution on both sides, same pressure  
Mounting options ..... 8

Pressure distribution on both sides, different pressure  
Mounting without internal cooling lubricant supply..... 9  
Mounting without internal cooling lubricant supply..... 10  
Mounting with internal cooling lubricant supply..... 11

**Product note**



## External cooling lubricant supply

### Delivery condition

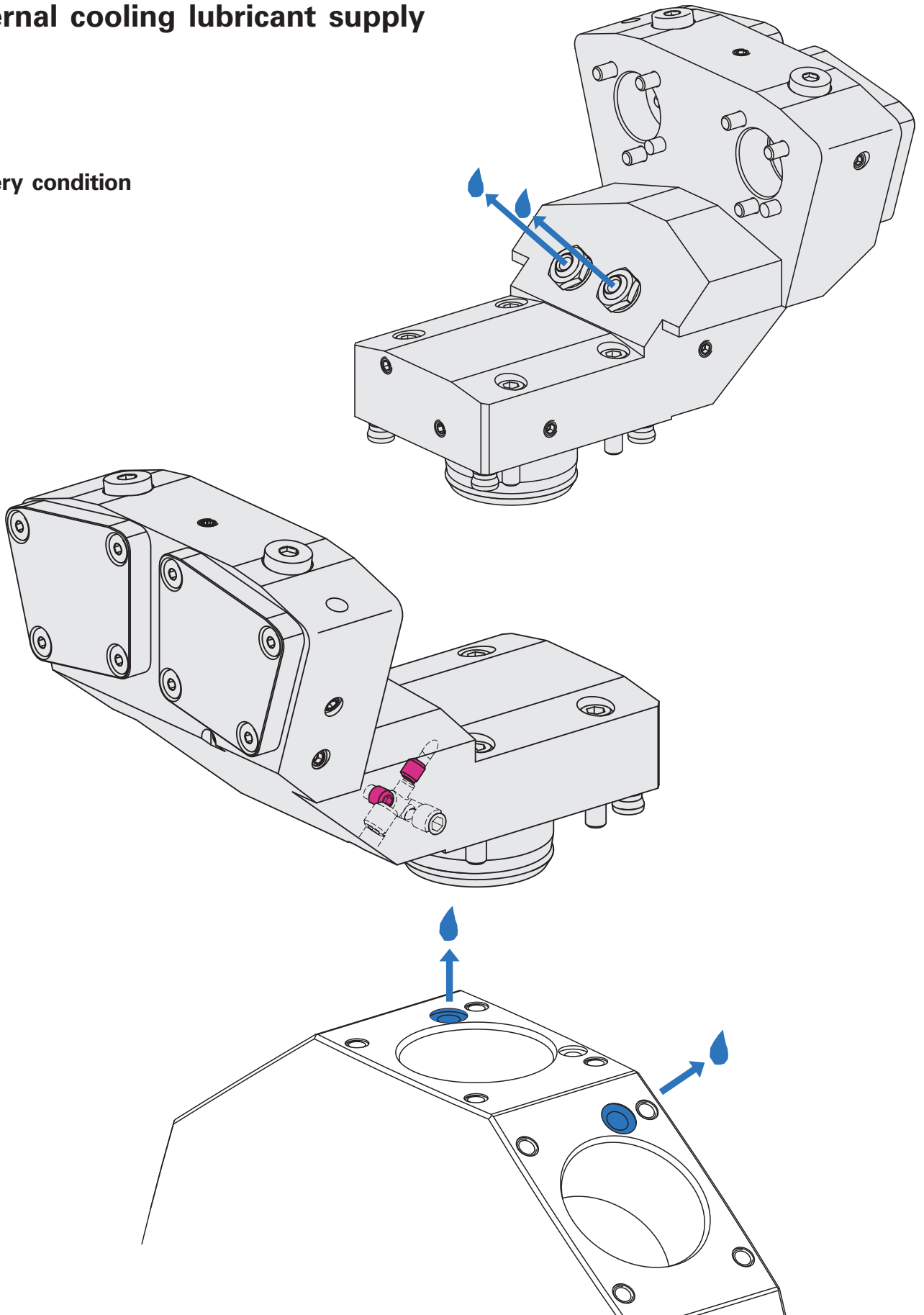

#### Product note

Cooling lubricant supply, Internal cooling lubricant supply with internal transfer, set screw  
W9800015EN-29.04.2014

## Internal cooling lubricant supply

### Normal pressure up to 80 bar

- Ball spray nozzles must be closed (set screws not included)

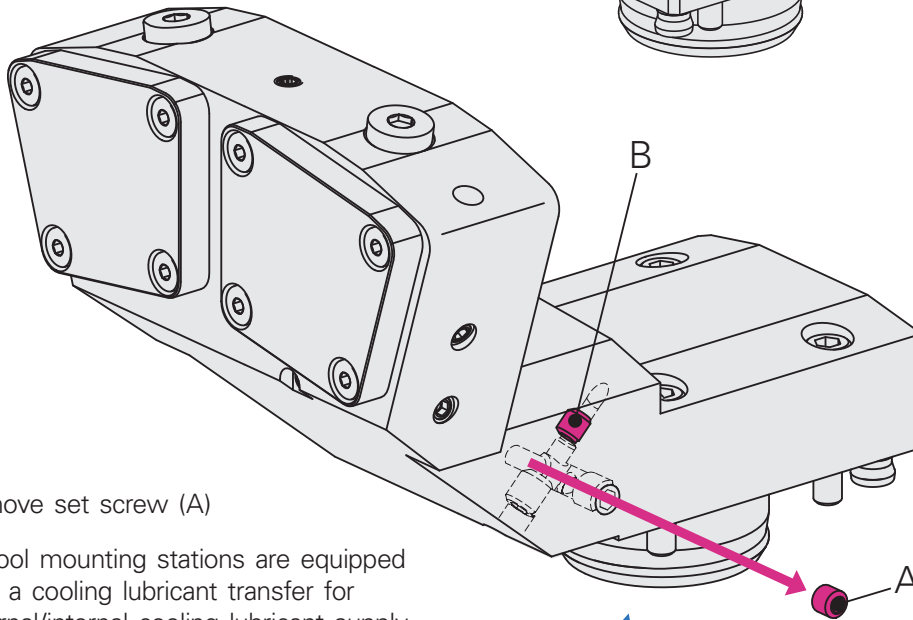
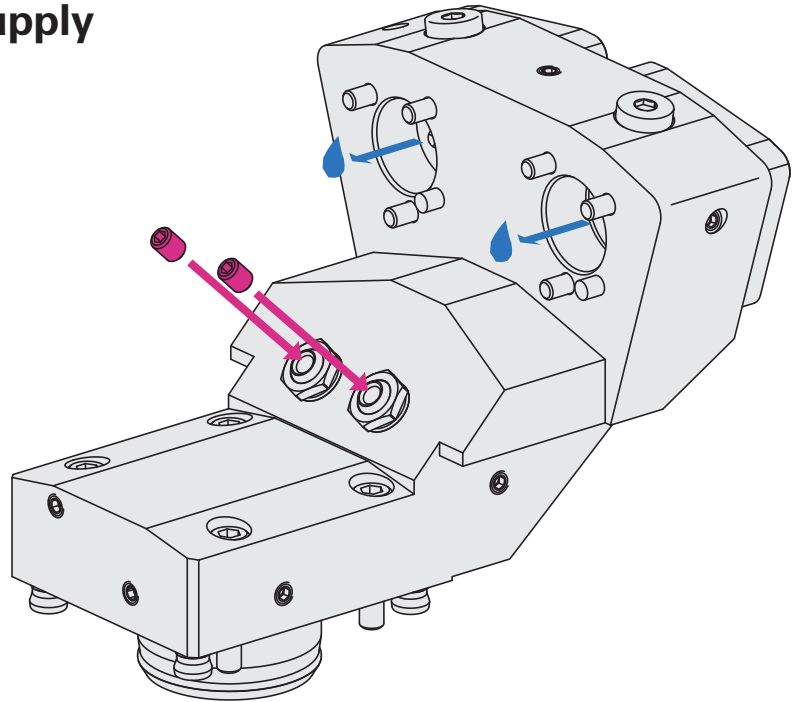

- Remove set screw (A)
- All tool mounting stations are equipped with a cooling lubricant transfer for external/internal cooling lubricant supply up to 80 bar

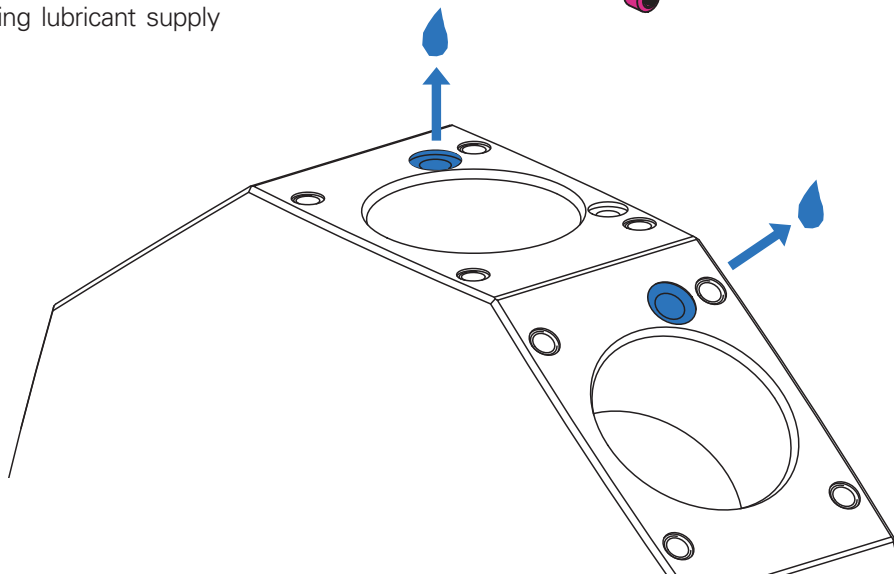

## Internal cooling lubricant supply

### High pressure above 80 bar

- Ball spray nozzles open, simultaneous exterior cooling lubricant supply up to 80 bar possible
- Ball spray nozzles can be closed (set screws not included)

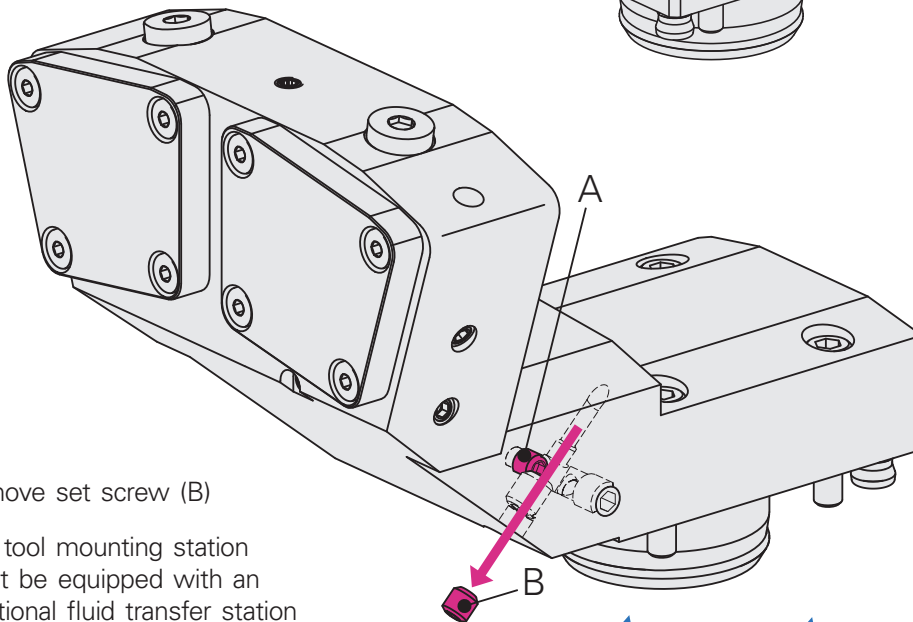
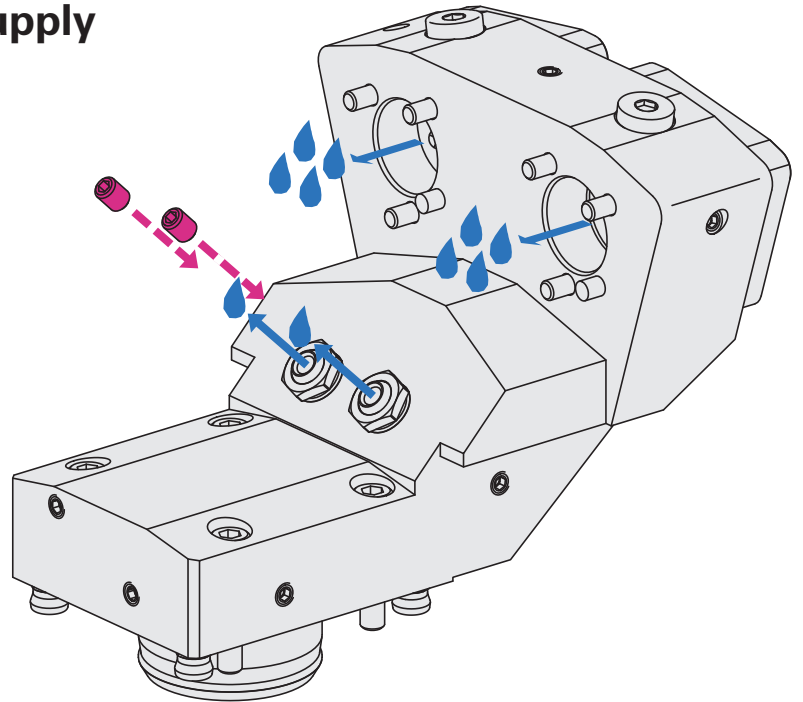

- Remove set screw (B)
- The tool mounting station must be equipped with an additional fluid transfer station
- This can be used as a sealing air port or as a high pressure air port
- The corresponding attachments must be present on the machine

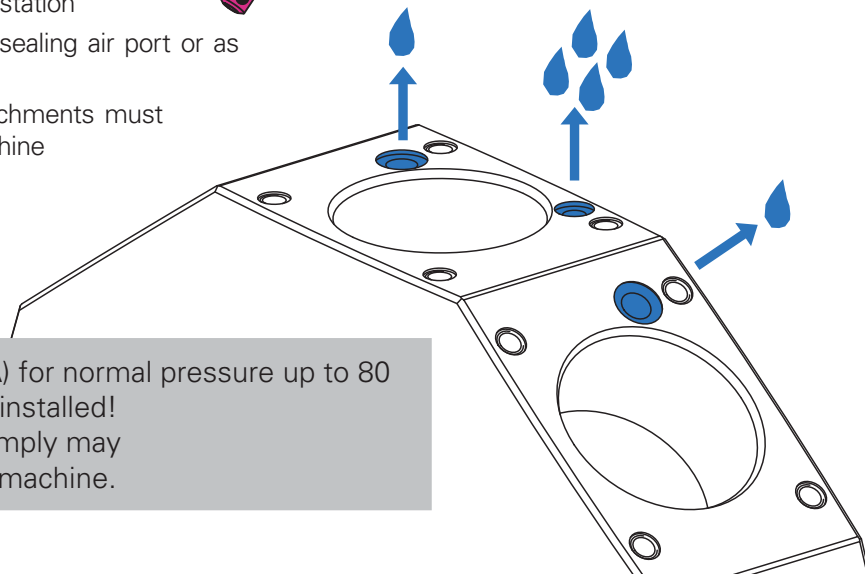

Set screw (A) for normal pressure up to 80 bar must be installed! Failure to comply may damage the machine.

**Product note**

Cooling lubricant supply, Internal cooling lubricant supply with internal transfer, set screw  
W9800015EN-29.04.2014

## Internal cooling lubricant supply

Pressure distribution on both sides, same pressure

Mounting options

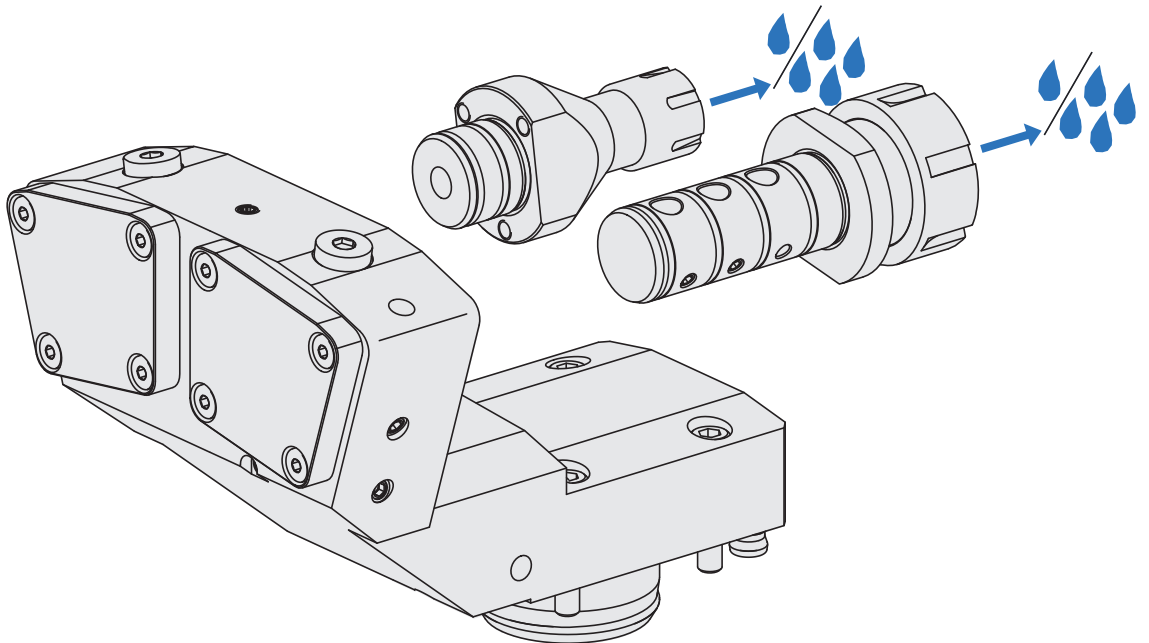

## Internal cooling lubricant supply

### Pressure distribution on both sides, different pressure

#### Mounting without internal cooling lubricant supply

- Close mounting (1) with set screw (2) before installation (set screw (2) not included)
- Insert mounting (1) and tighten with screws (3)
- Tighten cover (4) with screws (5)

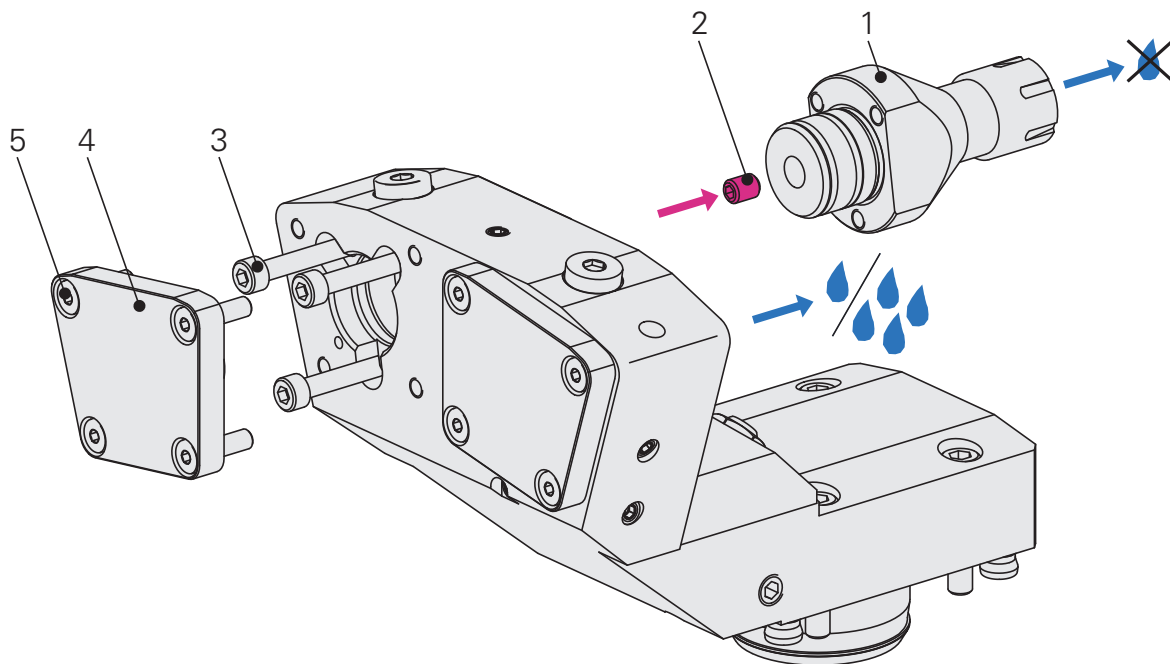

**Product note**

Cooling lubricant supply, Internal cooling lubricant supply with internal transfer, set screw  
W9800015EN-29.04.2014

## Internal cooling lubricant supply

### Pressure distribution on both sides, different pressure

#### Mounting without internal cooling lubricant supply

- Remove cover (11) and screws (10, 12)
- Remove blanking plug (9)
- Insert mounting (6), **closing** the desired coolant transfer hole (8) with a set screw (7)
- Install set screw (7) into the tool holder and tighten

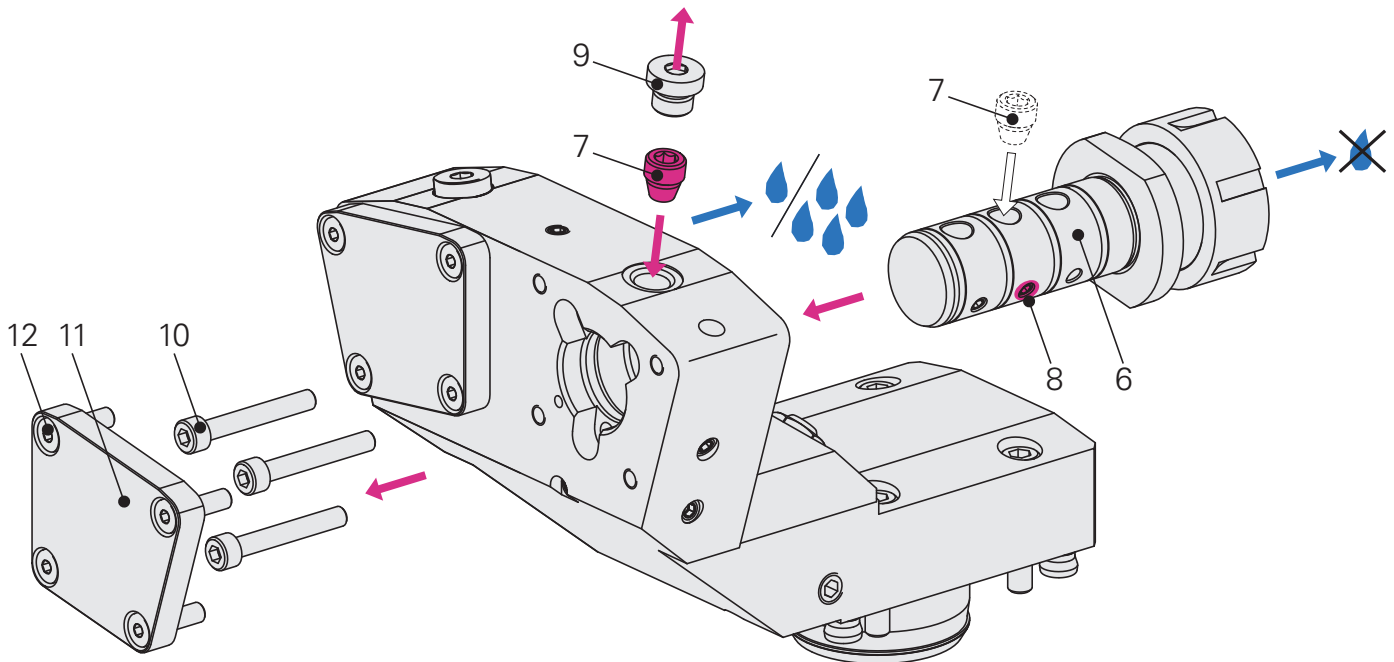



## Internal cooling lubricant supply

### Pressure distribution on both sides, different pressure

#### Mounting with internal cooling lubricant supply

- Remove cover (11) and screws (10, 12)
- Remove blanking plug (9)
- Insert mounting (6), making sure the desired coolant transfer hole (8) is **unobstructed**, modify set screw if necessary
- Install set screw (7) into the tool holder and tighten

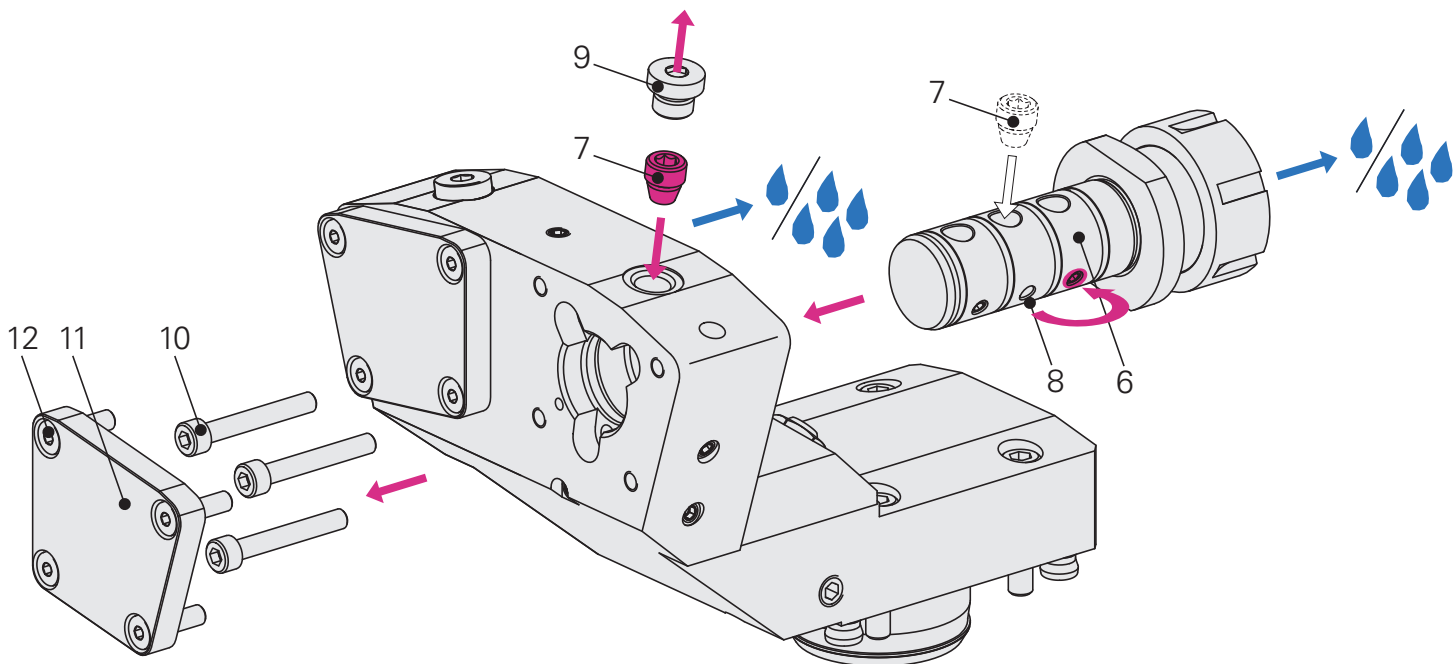

**Product note**

Cooling lubricant supply, Internal cooling lubricant supply with internal transfer, set screw  
W9800015EN-29.04.2014

# INDEX

**INDEX-Werke GmbH & Co. KG****Hahn & Tessky**

Plochinger Strasse 92  
D-73730 Esslingen, Germany  
[www.index-werke.de](http://www.index-werke.de)

**TRAUB-Drehmaschinen****GmbH & Co. KG**

Hauffstrasse 4  
D-73262 Reichenbach, Germany  
[www.traub.de](http://www.traub.de)

**TECHNICAL SUPPORT**

Phone +49 711 3191-9854  
Fax +49 711 90129-343  
[werkzeughalter@index-werke.de](mailto:werkzeughalter@index-werke.de)

**TECHNICAL SUPPORT**

Phone +49 7153 502-9854  
Fax +49 711 90129-343  
[werkzeughalter@traub.de](mailto:werkzeughalter@traub.de)

**SPARE PARTS SALE**

Phone +49 711 3191-600  
Fax +49 711 3191-790  
[ersatzteile@index-werke.de](mailto:ersatzteile@index-werke.de)

**SPARE PARTS SALE**

Phone +49 7153 502-600  
Fax +49 7153 502-685  
[ersatzteile@traub.de](mailto:ersatzteile@traub.de)

# Product note

## Cooling lubricant supply

External cooling lubricant supply

Internal cooling lubricant supply with internal transfer, blanking plug  
Normal pressure up to 80 bar  
High pressure above 80 bar

## **Disclaimer**

The illustrations in this documents may deviate from the delivered product. We reserve the right to make changes due to errors or based on technical advances.

## **A word on copyright**

This document is proprietary and was originally written in German. Its reproduction and distribution in whole or in individual parts without permission of the copyright owner is prohibited and will be prosecuted under criminal or civil law. All rights reserved, including for translation.

© Copyright by INDEX-Werke GmbH & Co. KG Esslingen 2014

© Copyright by TRAUB Drehmaschinen GmbH & Co. KG Reichenbach 2014

**External cooling lubricant supply**

Delivery condition .....	5
--------------------------	---

**Internal cooling lubricant supply**

Normal pressure up to 80 bar .....	6
High pressure above 80 bar.....	7

**Product note**

Cooling lubricant supply, internal cooling lubricant supply with internal transfer, blanking plug  
W9800024EN-29.04.2014



## External cooling lubricant supply

### Delivery condition

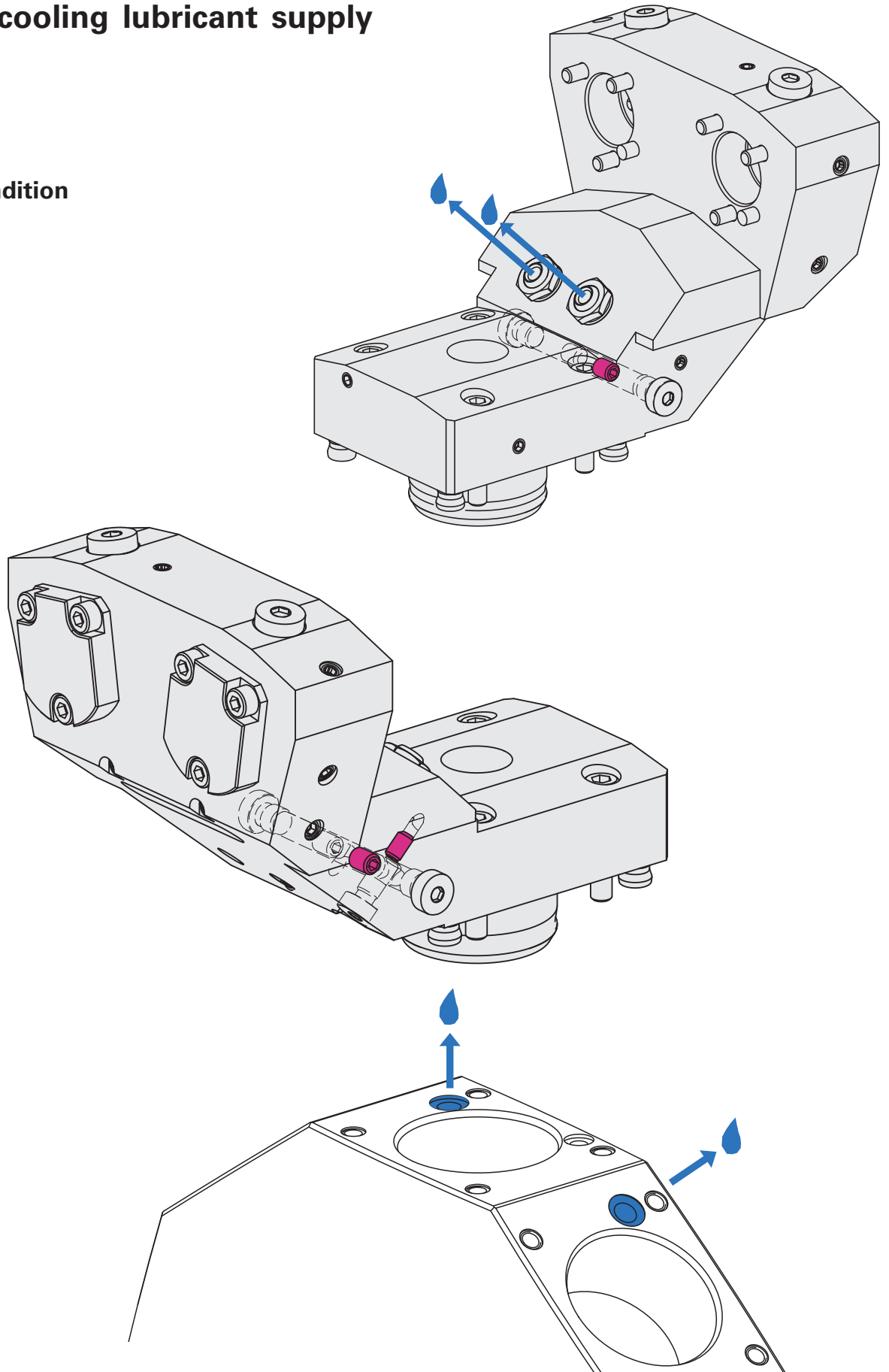

**Product note**

Cooling lubricant supply, internal cooling lubricant supply with internal transfer, blanking plug  
W9800024EN-29.04.2014

# Internal cooling lubricant supply

**Normal pressure up to 80 bar possible at both tool-mounting stations**

- Ball spray nozzles must be closed (M6 set screws (1) not included)
- Remove blanking plug (2)
- Remove set screw (3)
- Reinstall blanking plug (2)

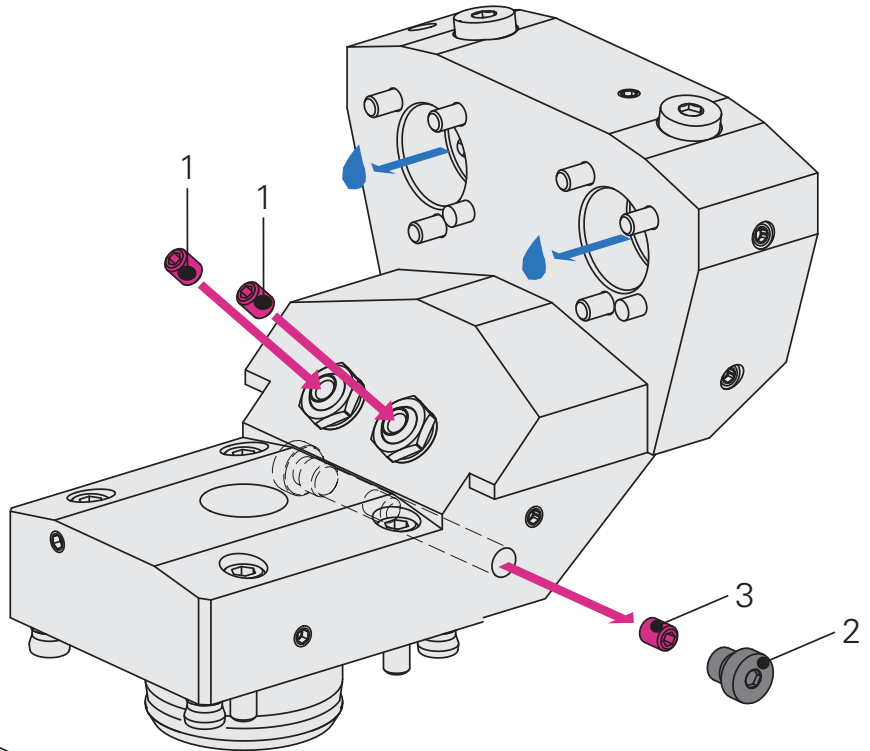

- Remove blanking plug (4)
- Remove set screw (5)
- Reinstall blanking plug (4)
- All tool mounting stations are equipped with a cooling lubricant transfer for external/internal cooling lubricant supply up to 80 bar

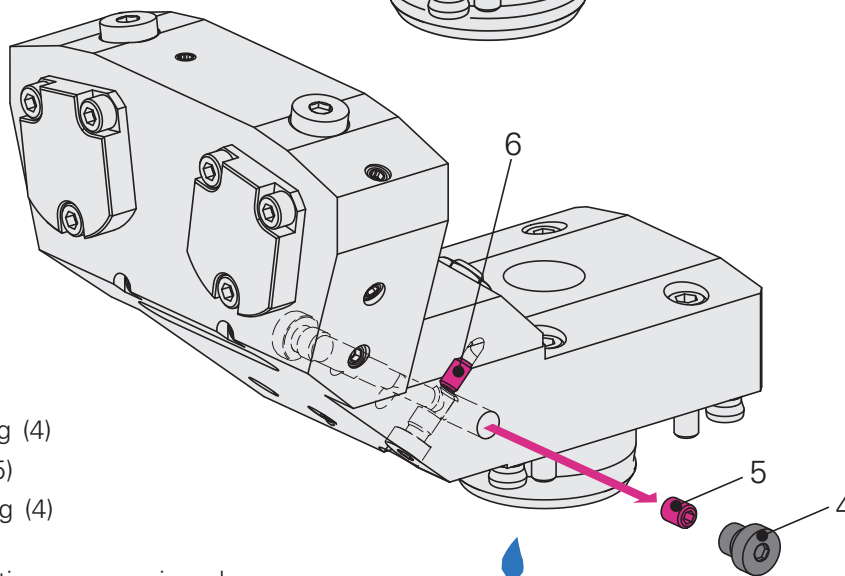

Set screw (6) must be installed in bore!  
Failure to comply may cause damage to the machine.

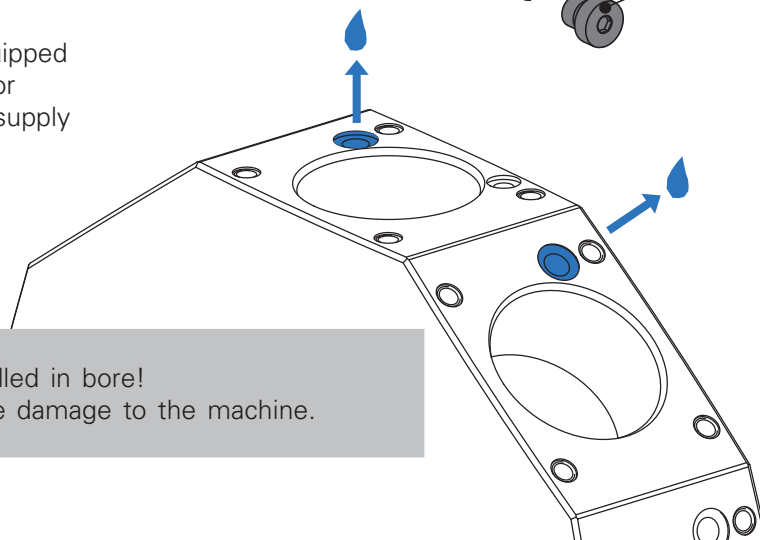



# Internal cooling lubricant supply

## High pressure above 80 bar

possible only at one tool mounting station

second tool mounting station optionally with external cooling lubricant supply or internal cooling lubricant supply, normal pressure

- Ball spray nozzles open, simultaneous external cooling lubricant supply up to 80 bar possible
- Ball spray nozzles can be closed

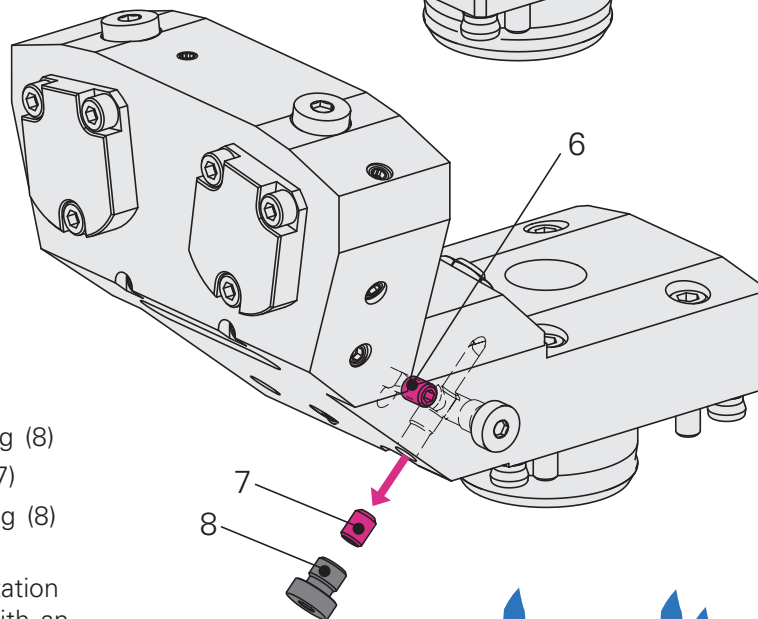
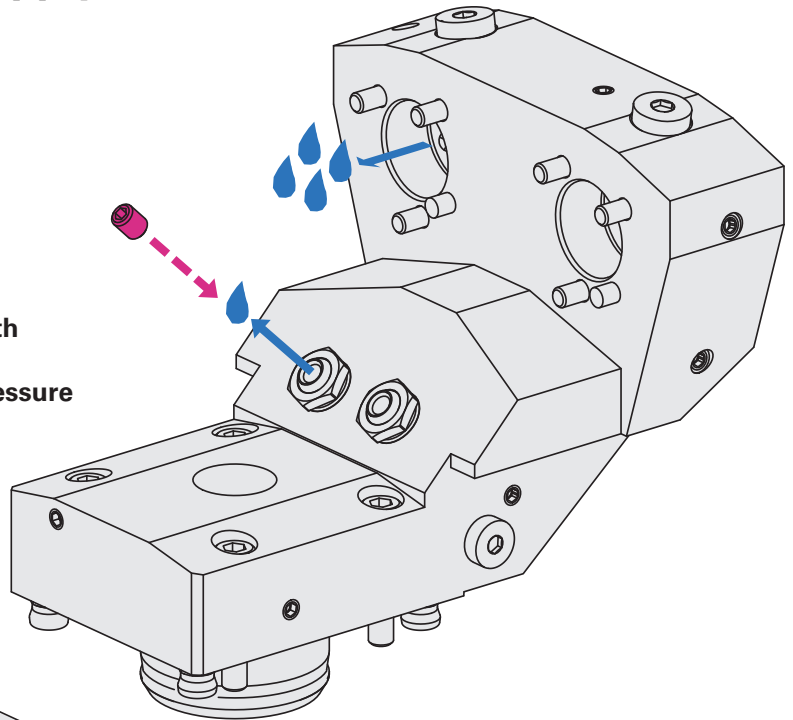

- Remove blanking plug (8)
- Remove set screw (7)
- Reinstall blanking plug (8)
- The tool mounting station must be equipped with an additional fluid transfer station
- This can be used as a sealing air port or as a high pressure air port
- The corresponding attachments must be present on the machine

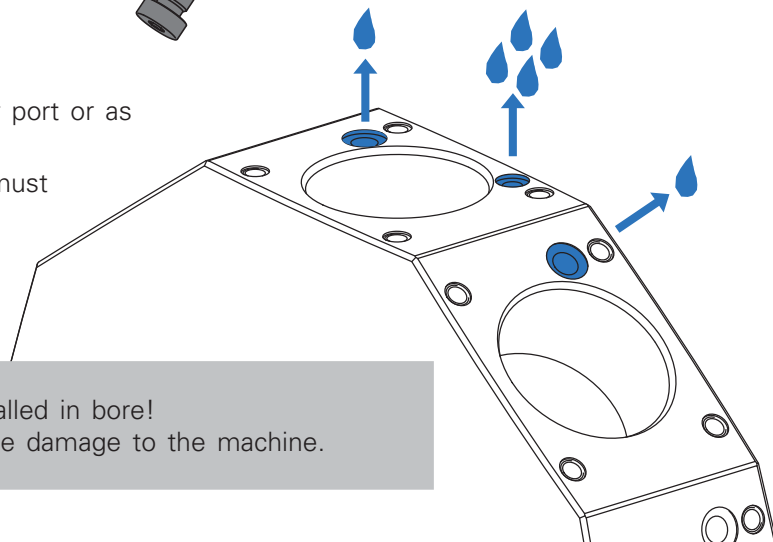

Set screw (6) must be installed in bore!  
Failure to comply may cause damage to the machine.

# INDEX

**INDEX-Werke GmbH & Co. KG****Hahn & Tessky**

Plochinger Strasse 92  
D-73730 Esslingen, Germany  
[www.index-werke.de](http://www.index-werke.de)

**TRAUB-Drehmaschinen****GmbH & Co. KG**

Hauffstrasse 4  
D-73262 Reichenbach, Germany  
[www.traub.de](http://www.traub.de)

**TECHNICAL SUPPORT**

Phone +49 (0) 711 3191-9854  
Fax +49 (0) 711 90129-343  
[werkzeughalter@index-werke.de](mailto:werkzeughalter@index-werke.de)

**TECHNICAL SUPPORT**

Phone +49 (0) 7153 502-9854  
Fax +49 (0) 711 90129-343  
[werkzeughalter@traub.de](mailto:werkzeughalter@traub.de)

**SPARE PARTS SALE**

Phone +49 (0) 711 3191-600  
Fax +49 (0) 711 3191-790  
[ersatzteile@index-werke.de](mailto:ersatzteile@index-werke.de)

**SPARE PARTS SALE**

Phone +49 (0) 7153 502-600  
Fax +49 (0) 7153 502-685  
[ersatzteile@traub.de](mailto:ersatzteile@traub.de)

# Product note

## Cooling lubricant supply

External cooling lubricant supply

Internal cooling lubricant supply with external transfer  
Normal pressure up to 80 bar  
High pressure above 80 bar

## **Disclaimer**

The illustrations in this documents may deviate from the delivered product. We reserve the right to make changes due to errors or based on technical advances.

## **A word on copyright**

This document is proprietary and was originally written in German. Its reproduction and distribution in whole or in individual parts without permission of the copyright owner is prohibited and will be prosecuted under criminal or civil law. All rights reserved, including for translation.

© Copyright by INDEX-Werke GmbH & Co. KG Esslingen 2014

© Copyright by TRAUB Drehmaschinen GmbH & Co. KG Reichenbach 2014

**Delivery condition**

Pressure distribution ..... 4

**Use with external cooling lubricant supply**..... 5

**Use with internal cooling lubricant supply, external transfer**

Normal pressure up to 80 bar ..... 6

High pressure above 80 bar..... 7

## Delivery condition

## Pressure distribution

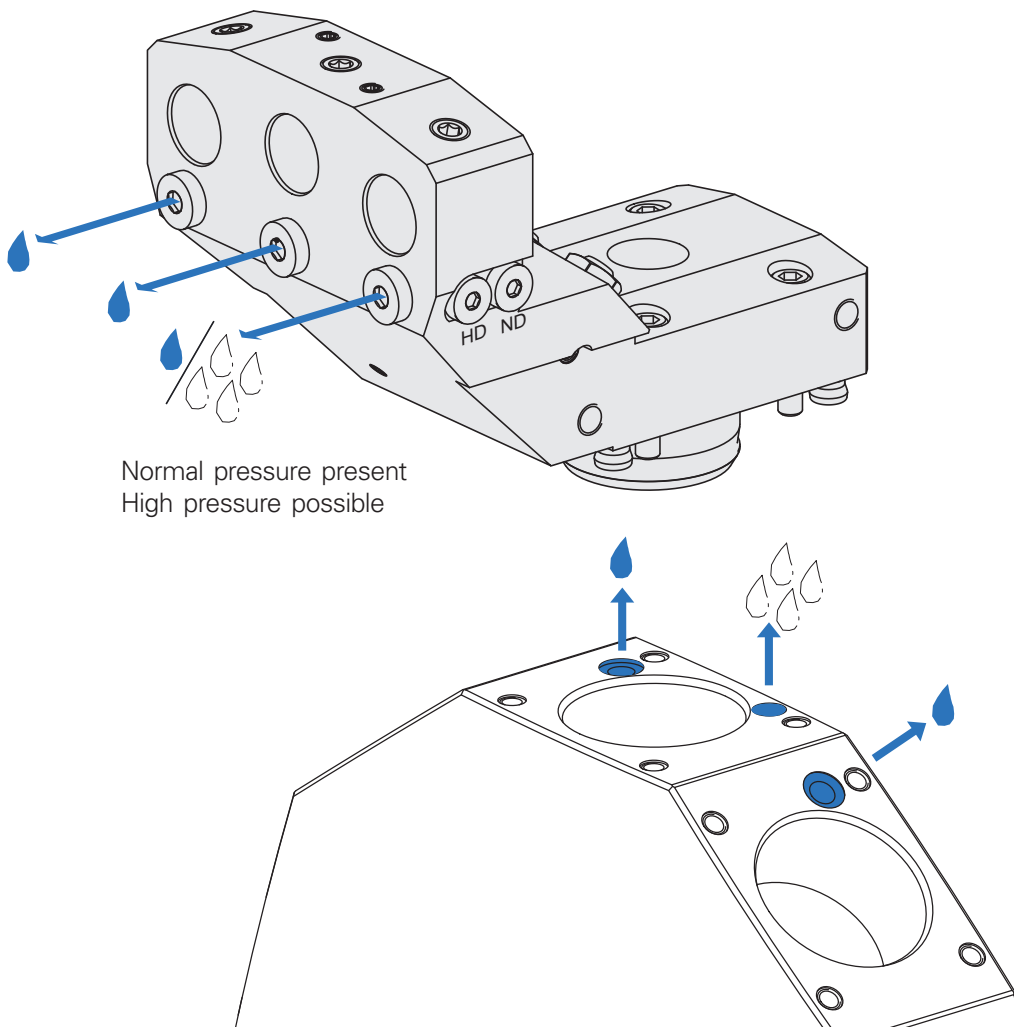

## Use with external cooling lubricant supply

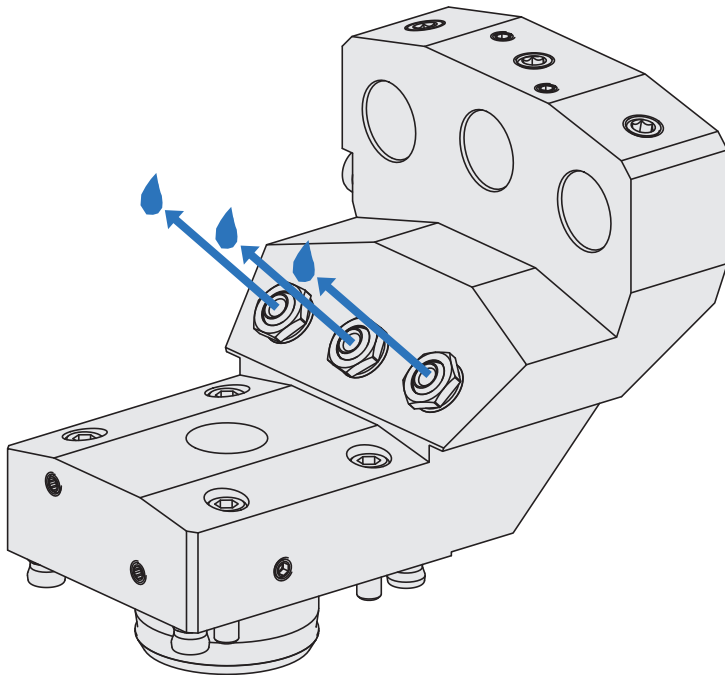

**Product note**

Cooling lubricant supply, Internal cooling lubricant supply with external transfer  
W9800023EN-15.01.2014

**Use with  
internal cooling lubricant supply  
external transfer**

**Normal pressure up to 80 bar**

- Ball spray nozzles must be closed (set screws M6 (1) not included)

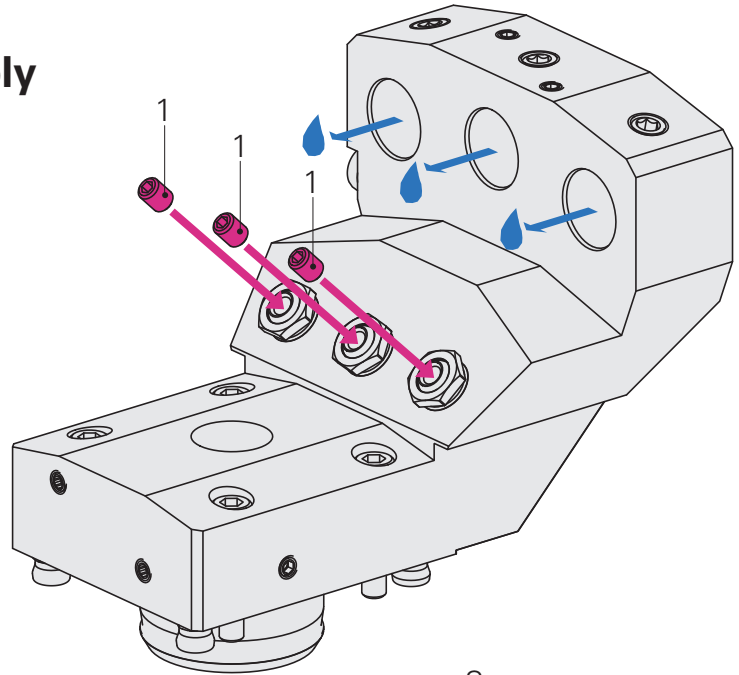

- Remove blanking plugs (2)
- Insert set screw (3) in hole HD
- Reinstall blanking plugs (2)
- Remove blanking plug (4)
- Insert screw connection (5)
- Remove blanking plug (7)
- Introduce mounting (8)
- Insert screw connection (6)

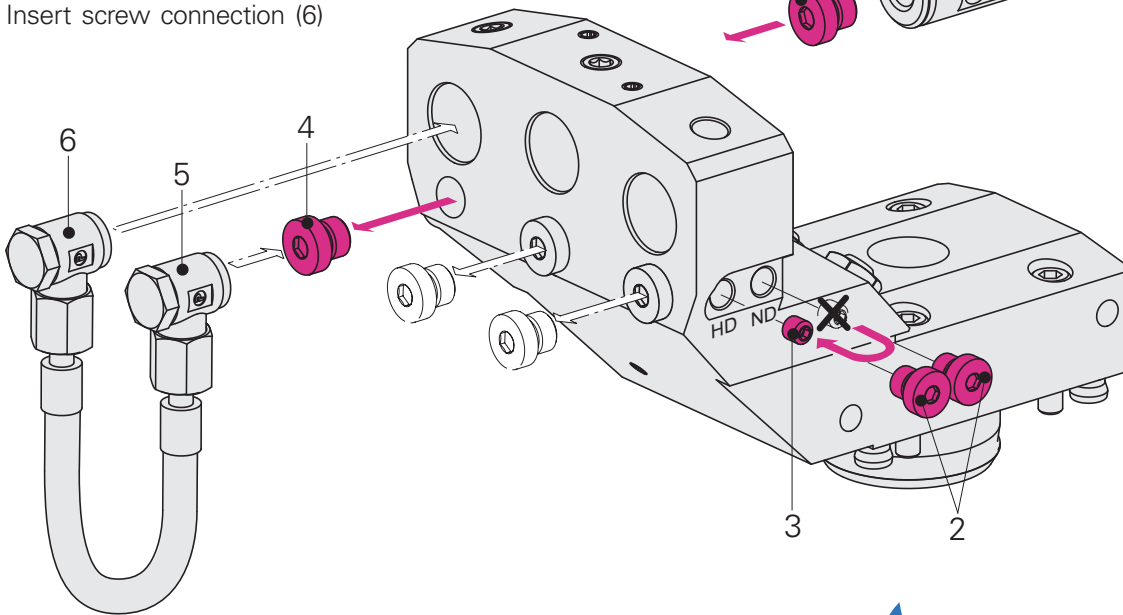
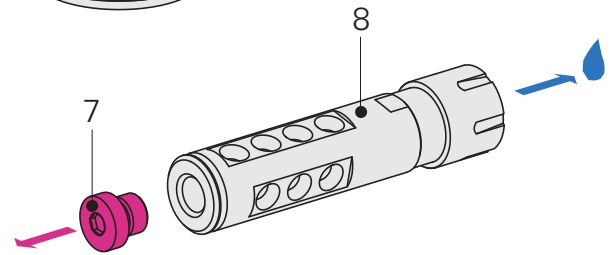

- All tool stations on the turret head are equipped with a cooling lubricant transfer up to 80 bar

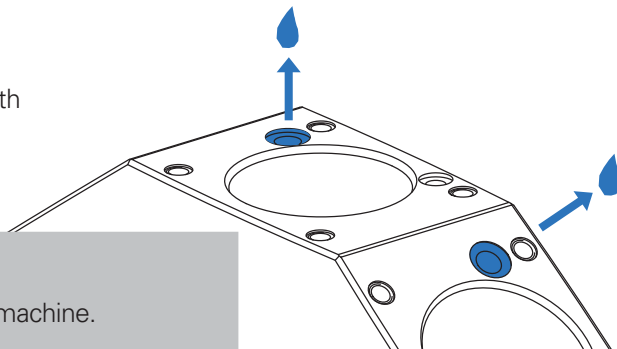

Set screw (3) must be mounted in hole HD!  
Failure to comply may cause damage to the machine.



## Use with internal cooling lubricant supply external transfer

### High pressure above 80 bar

- Ball spray nozzles open, simultaneous exterior cooling lubricant supply up to 80 bar possible
- Ball spray nozzles can be closed (set screw M6 (1) not included)
- Remove blanking plugs (2)
- Insert set screw (3) in hole ND
- Reinstall blanking plugs (2)
- Remove blanking plug (4)
- Insert screw connection (5)
- Remove blanking plug (7)
- Introduce mounting (8)
- Insert screw connection (6)

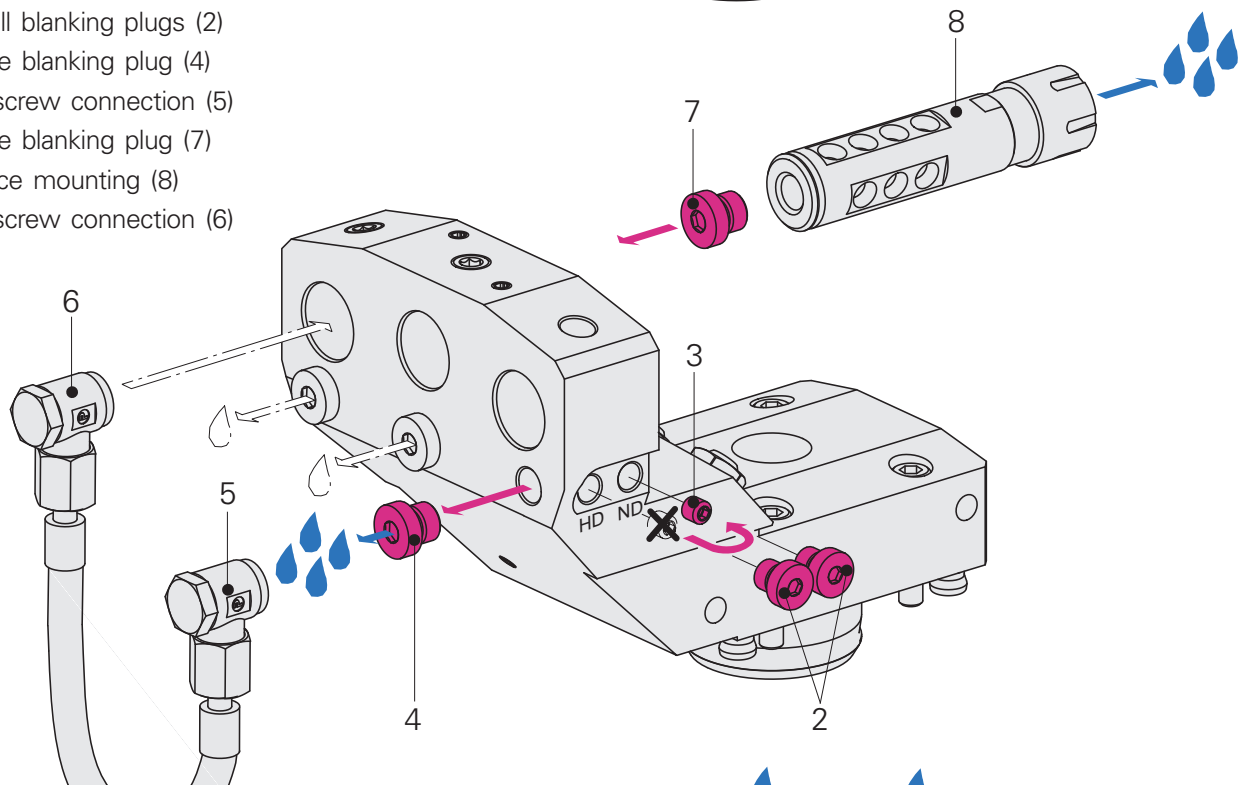
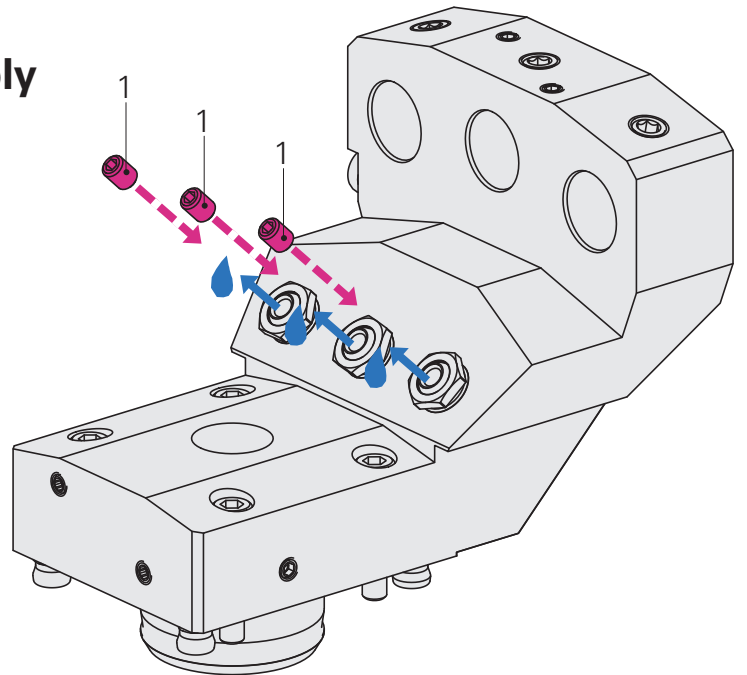

- The tool station must be equipped with an additional fluid transfer station. This can be used as a sealing air port or as a high pressure air port.
- The corresponding attachments must be present on the machine.

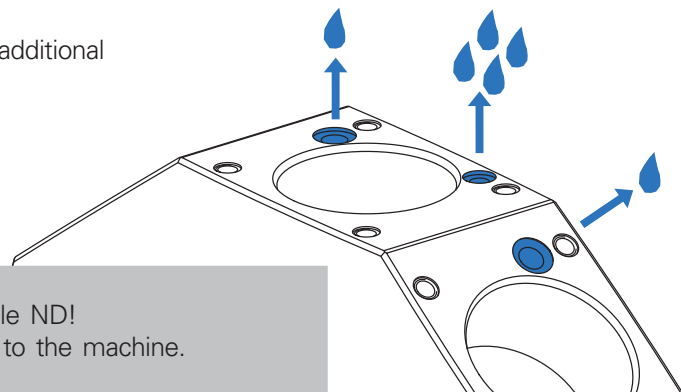

Set screw (3) must be mounted in hole ND!  
Failure to comply may cause damage to the machine.

**Product note**

Cooling lubricant supply, Internal cooling lubricant supply with external transfer  
W9800023EN-15.01.2014

# INDEX



## **INDEX-Werke GmbH & Co. KG**

### **Hahn & Tessky**

Plochinger Strasse 92  
D-73730 Esslingen, Germany  
[www.index-werke.de](http://www.index-werke.de)

### **TECHNICAL SUPPORT**

Phone +49 711 3191-9854  
Fax +49 711 90129-343  
[werkzeughalter@index-werke.de](mailto:werkzeughalter@index-werke.de)

### **SPARE PARTS SALE**

Phone +49 711 3191-600  
Fax +49 711 3191-790  
[ersatzteile@index-werke.de](mailto:ersatzteile@index-werke.de)

## **TRAUB-Drehmaschinen**

### **GmbH & Co. KG**

Hauffstrasse 4  
D-73262 Reichenbach, Germany  
[www.traub.de](http://www.traub.de)

### **TECHNICAL SUPPORT**

Phone +49 7153 502-9854  
Fax +49 711 90129-343  
[werkzeughalter@traub.de](mailto:werkzeughalter@traub.de)

### **SPARE PARTS SALE**

Phone +49 7153 502-600  
Fax +49 7153 502-685  
[ersatzteile@traub.de](mailto:ersatzteile@traub.de)



# INDEX



**INDEX-Werke GmbH & Co. KG  
Hahn & Tessky**  
Plochinger Straße 92  
D-73730 Esslingen, Germany  
[www.index-werke.de](http://www.index-werke.de)

**TRAUB-Drehmaschinen  
GmbH & Co. KG**  
Hauffstraße 4  
D-73262 Reichenbach, Germany  
[www.traub.de](http://www.traub.de)

**TECHNICAL ADVICE**  
Phone +49 (0) 711 3191-9854  
Fax +49 (0) 711 90129-343  
[werkzeughalter@traub.de](mailto:werkzeughalter@traub.de)

**TECHNICAL ADVICE**  
Phone +49 (0) 7153 502-9854  
Fax +49 (0) 711 90129-343  
[werkzeughalter@traub.de](mailto:werkzeughalter@traub.de)

**SPARE PARTS SALE**  
Phone +49 (0) 711 3191-600  
Fax +49 (0) 711 3191-790  
[ersatzteile@index-werke.de](mailto:ersatzteile@index-werke.de)

**SPARE PARTS SALE**  
Phone +49 (0) 7153 502-600  
Fax +49 (0) 7153 502-685  
[ersatzteile@traub.de](mailto:ersatzteile@traub.de)