

Straight tool holders with internal cooling

NEW GENERATION

Straight tool holders with internal cooling - New generation

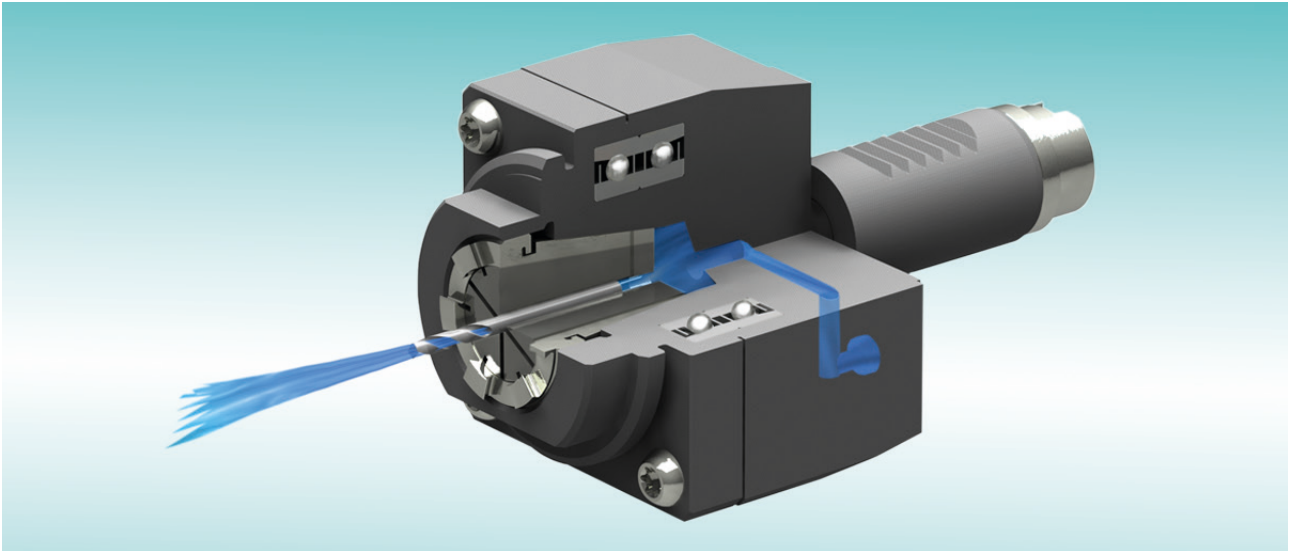

The internal coolant supply on straight live tool holders, which has been tried and tested for years, has been optimized and replaced by a successor variant.

The new solution is now even more powerful with a shorter design.

The main advantages are:

- short, space-saving design
- up to 15 mm shorter compared to currently available products
- maximum speed is possible at maximum pressure (80 bar)
- low-wear coated sealing surfaces
- seal is suitable for dry running

The optimized internal cooling of tool holders enables an increase in the service life of cutting tools of up to 30% compared to tool holders with external cooling.

This tool life extension makes these tool holders significantly more productive and thus also more economical.

In our iXshop, you will find the matching sealing washers and sealed collets in the *tool holders and accessories* section.

Please feel free to contact us if you have any further questions +49 711 3191-9854 or visit us online: ixshop.ixworld.com

INDEX

INDEX-Werke GmbH & Co. KG Hahn & Tessky

Plochinger Straße 92
D-73730 Esslingen

Fon +49 711 3191-0
Fax +49 711 3191-587

info@index-werke.de
www.index-werke.de