

## **Multi-spindle indexing turret for stationary / live tools**

## Multi-spindle indexing turret for stationary / live tools

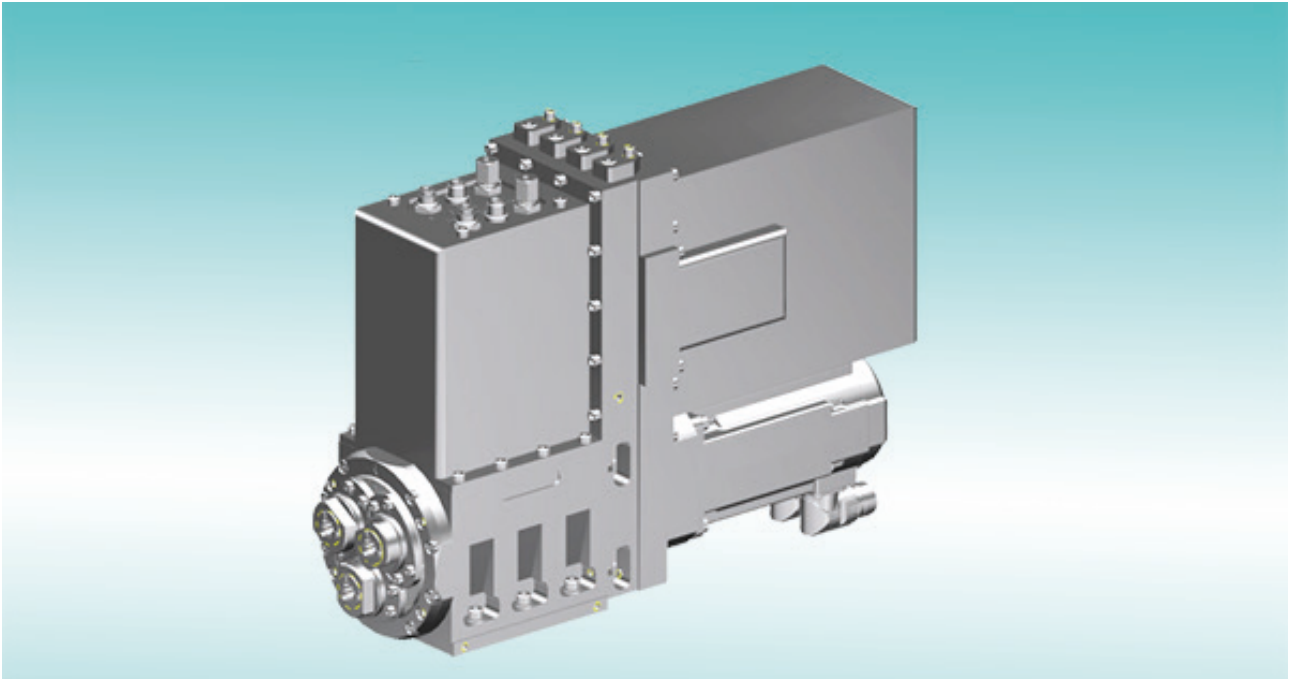

With the new indexing turrets for INDEX multi-spindle machines, you can use up to three different tools at one position.

This provides many advantages for you:

- Reducing cycle times by very short turret indexing times, e.g., in drilling and tapping at one position
- Low setup effort in the production of part families
- More available tool locations in the machine

Changing tools is particularly easy and fast by using a quick exchange system. And the tools can be preset outside the machine, reducing the setup time.

The indexing turret can be used only if the machine is equipped with the necessary options!

If you have further questions, don't hesitate to call us at +49 711 3191-9854 or send us an email to [werkzeughalter@index-werke.de](mailto:werkzeughalter@index-werke.de).

Part number

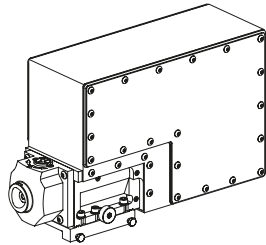

**Multi-spindle indexing turret**  
**Slide system** MS16/MS22  
 Mounting INDEX TRAUB CAPTO C4  
 Speed ratio –  
 X / Y / Z 23.9 / – / 50.3 mm

10072866



**Multi-spindle indexing turret**  
**Slide system** MS32/MS40  
 Mounting INDEX TRAUB CAPTO C4  
 Speed ratio –  
 X / Y / Z 23.5 / – / 54.3 mm

10599456

**Multi-spindle indexing turret**  
**Slide system** MS52  
 Mounting INDEX TRAUB CAPTO C4  
 Speed ratio –  
 X / Y / Z 7.9 / – / 54.3 mm

10367187

**Turning tool holder for 3 turning tools**  
 INDEX TRAUB CAPTO C4

10421705

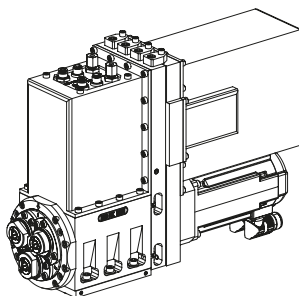

**Multi-spindle indexing turret, direct drive**  
**Slide system** MS16/MS22  
 Mounting ER 16  
 Transmission ratio 1:1.06 (0.944)  
 X / Y / Z 29.8 / – / 37 mm

11063174

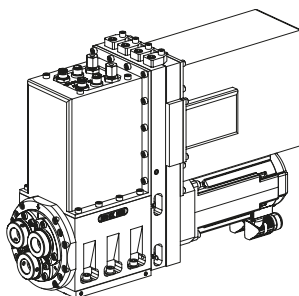

**Multi-spindle indexing turret, direct drive**  
**Slide system** MS32/MS40  
 Mounting ER 16  
 Transmission ratio 1:1.06 (0.944)  
 X / Y / Z 22.5 / – / 39 mm

10839861

**Multi-spindle indexing turret, direct drive**  
**Slide system** MS52  
 Mounting ER 16  
 Transmission ratio 1:1.06 (0.944)  
 X / Y / Z 34.3 / – / 39 mm

10434708

**Multi-spindle indexing turret, direct drive**  
**Slide system** MS16/MS22  
 Mounting WFB 20-12  
 Transmission ratio 1:1.06 (0.944)  
 X / Y / Z 29.8 / – / 37 mm

10567831

**Multi-spindle indexing turret, direct drive**  
**Slide system** MS32/MS40  
 Mounting WFB 20-12  
 Transmission ratio 1:1.06 (0.944)  
 X / Y / Z 22.5 / – / 39 mm

10234745

**Multi-spindle indexing turret, direct drive**  
**Slide system** MS52  
 Mounting WFB 20-12  
 Transmission ratio 1:1.06 (0.944)  
 X / Y / Z 34.3 / – / 39 mm

10587848

# INDEX

## **INDEX-Werke GmbH & Co. KG Hahn & Tessky**

Plochinger Straße 92  
D-73730 Esslingen

Fon +49 711 3191-0  
Fax +49 711 3191-587

[info@index-werke.de](mailto:info@index-werke.de)  
[www.index-werke.de](http://www.index-werke.de)