



INDEX B400

from machine No. 12010119

TRAUB TNA400.2

from machine No. 12020123

Tool holder

Technical Information

Note on applicability

Illustrations in this publication may deviate from the product supplied. Errors and omissions due to technical progress expected.

A word on copyright

This document is protected by copyright and was originally compiled in German. The duplication and distribution of this document or parts thereof is prohibited without prior consent of the copyright owner, and any violators will be prosecuted. All rights, including the right to translate, are reserved.

© Copyright by INDEX-Werke GmbH & Co. KG

Technical information	5
Tool holder selection	5
Warranty	5
Information on wear parts	5
Inspection of live tool holders	5
Tool holders with cooling lubricant supply	6
Cooling lubricant filtering	6
Cleaning live tool holders	6
Speed ratio specifications on tool holders	6
Direction of rotation specification	7
Tightening torque	8
Coolant supply	8
Replacement seals for tool shank	8
Sealing air port	8
Tool holders with fixation	9
High-pressure unit	9
Load limits of live tools	9
Live tool holders	10
Radial turret	10
Disk-type turret	11
Weight distribution on turret head	12
Collision	12
Tool change on live tool holders	12
Notes on how to use the diagram when using tool holders	13
 Usage information	 15
Modular system of INDEX B400, TRAUB TNA400.2	15
Work area	
INDEX B400 from machine No. 12010119, TRAUB TNA400.2 from machine No. 12020123	16
Radial turret VDI30, NC tailstock	16
Radial turret VDI30, Counter spindle	18
Radial turret VDI40, NC tailstock	20
Radial turret VDI40, Counter spindle	22
Disk-type turret VDI40, NC tailstock	24
Swivel range INDEX B400, TRAUB TNA400.2	26
Radial turret with tooling system VDI30	26
Radial turret with tooling system VDI40	27
Disk-type turret with tooling system VDI40	28
Performance diagram valid for INDEX B400	30
Live tools VDI30, Radial turret	30
Live tools VDI40, Radial turret and Disk-type turret	31
Performance diagram valid for TRAUB TNA400.2	32
Live tools VDI30, Radial turret	32
Live tools VDI40, Radial turret and Disk-type turret	33

Tool holder selection



For more information, please visit our iXshop at ixshop.index-traub.com

We will be happy to send you an individual offer. Just call us at +49 711 3191-9854 or send us an email to werkzeughalter@index-werke.de.

Warranty



When using tool holders that are not adjusted, tested and marked as such by INDEX TRAUB, the warranty for the tool drive is void.

Information on wear parts

Tool holders are wear parts requiring correct handling. In order to ensure a long service life, compressed air or coolant must not enter the gap seals of the holders.

Inspection of live tool holders



Tool holders must be inspected at regular intervals (at least twice a year) for smooth running and play.



The drive pinion and drive clutch of the live tool holders must be subjected to a visual inspection for damage or wear.

If one of the above-mentioned defects is detected during the inspection of the tool holders, they must be returned immediately for preventive maintenance or repair to the following address:

INDEX-Werke GmbH & Co. KG
Plochinger Straße 92
D-73730 Esslingen
Fon +49 711 3191-554
werkzeughalter@index-werke.de

Tool holders with cooling lubricant supply



Tool holders marked with this symbol must be operated with cooling lubricant (no dry running permitted).



Tool holders marked with this symbol can be converted from external cooling lubricant supply to internal cooling lubricant supply. Observe dry running capability of IC attachment!

Cooling lubricant filtering

When using live tool holders with internal cooling lubricant supply, it is necessary to use a cooling lubricant filter system with a retained particle size $\leq 50 \mu\text{m}$.

Cleaning live tool holders

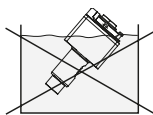

Live tool holders must never be immersed in cleaning fluid since mixing the cleaning fluid with the bearing grease will reduce the service life of the tool holders.

Speed ratio specifications on tool holders

The value to be programmed is specified in the documentation and on the live tool holders (= the input in the NC program).

$$n_{\text{prog}} = n_{\text{tool}} \times i$$

n_{tool} = speed at the cutting tool edge

n_{PROG} = speed to be programmed

i = speed ratio in the tool holder

This means the speed increase or speed reduction is not specified as a fraction but as **a number**.

This gives speed **increase** ratios as numbers **less than 1**.

Example: $i = 0.333$ (corresponds to $i = 1:3$)
 $i = 0.676$ (corresponds to $i = 1:1.48$)

Speed reduction ratios are numbers greater than 1.

Example: $i = 2$ (corresponds to $i = 2:1$)
 $i = 1.333$ (corresponds to $i = 4:3$)

Direction of rotation specification

Definition of the viewing direction.

Viewing direction for determining the direction of rotation is always from behind (that is, from the drive direction) toward the shaft.

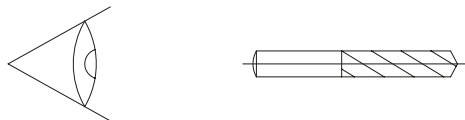

On the machine side, the direction of rotation has been set by parameters such that M03 always denotes clockwise rotation and M04 counter-clockwise rotation at the interface of the drive pinion of the tool holder.

The direction of rotation given on the holder therefore refers to a “change in direction within the holder”. M03 and M04 are machine functions to be programmed. The ↻ and ↺ arrows indicate the direction of rotation of the cutting edges.

This means:



No reversal of direction of rotation

When the holder drive shaft has the **same** direction of rotation as the tool cutting edge, the clockwise direction of run must be specified by M03 (clockwise rotation). Accordingly, counter-clockwise rotation must be specified by M04.



Reversal of direction of rotation

When the holder drive shaft has the **opposite** direction of rotation as the tool cutting edge, the clockwise direction of rotation must be specified by M04. Accordingly, counter-clockwise rotation must be specified by M03.

Example

No reversal of direction of rotation

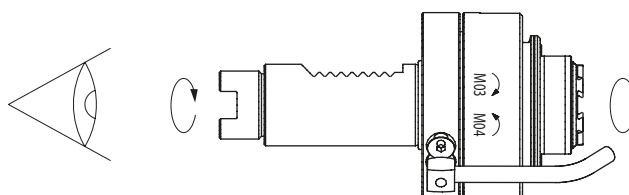

Tightening torque

The tightening torques of the clamping pieces to the tool holder mounting depends on the shank diameter of the tool holder.

Shank size	Tightening torque
∅ 20mm	8 Nm
∅ 25mm	20 Nm
∅ 30mm	25 Nm
∅ 40mm	40 Nm

Coolant supply

For tools with W-serration and double clamping serration, the 2nd hole for coolant supply must be closed by the end plug and the seal.

The gaskets on the tool shank and the coolant bushing must be regularly checked for damages.

Replacement seals for tool shank

The gaskets on the tool shank and the cooling lubricant bushing must be regularly checked for damages.

O-ring	Material number	Installation location
∅ 18.77 x 1.78	10763730	Shank ∅ 20mm
∅ 23.52 x 1.78	10823023	Shank ∅ 25mm
∅ 28.3 x 1.78	10777976	Shank ∅ 30mm
∅ 37.77 x 2.62	10066870	Shank ∅ 40mm
∅ 9.75 x 1.78	10046965	Cooling lubricant adapter
∅ 12.42 x 1.78	10824672	Cooling lubricant adapter

Sealing air port

It must be ensured on all machines with sealing air ports that the sealing air ports in the tool carrier and in the tool holders are sealed/closed with M5x6 mm set screws.

Tool holders with fixation



Except for very few cases, all tool holders have been pre-adjusted with high precision and sealed with the INDEX V bar / TRAUB adjusting bar / W-serration.

This setting must not be changed.

The INDEX V bar / TRAUB adjusting bar / W-serration ensures positional accuracy of the tool when re-inserted.

The tool holders are fixed around the shank axis by pins (DIN 69880).

DIN holders can be used.

Double serration of the tool holders allows several uses.

High-pressure unit



The cooling lubricant up to 80 bar (e.g., for deep-hole drilling) is supplied through the standard cooling lubricant line.

Load limits of live tools

The drive power and torques are indicated in the performance charts. These values represent the upper limit of the calculated theoretical performance values (average values). In case of interrupted cuts, e.g., for milling, the load peaks occurring when the cutting edge enters the material may be much higher than the theoretical torque according to the performance chart.



The cutter should be selected so that a cutting edge is constantly being used for cutting during the machining process.

Live tool holders

Only the tool located in the working position is live.

The live tool holders are inserted into the mounting bores in the tool carriers just like non-live tool holders.

Each turret station can accept one live tool.

The motor drives the tool that is exclusively in working position. In addition, the index drive is actuated by switching using the same motor.

Radial turret



The sealing washer (1) must be removed first.

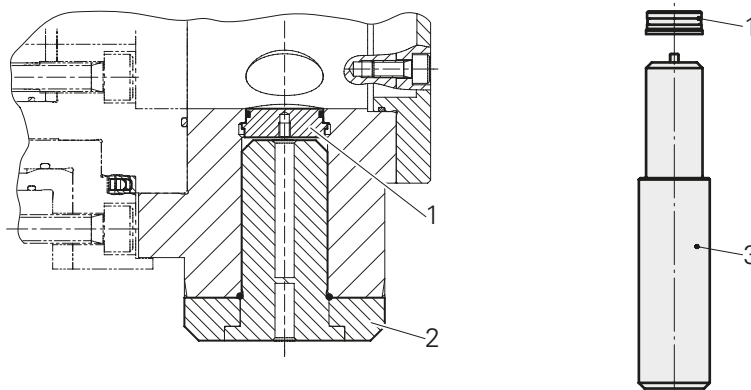

- | | | |
|---|----------------|---------------------------------|
| 1 | Sealing washer | VDI30 10346973 / VDI40 12014790 |
| 2 | Blanking plug | VDI30 10581081 / VDI40 10911003 |
| 3 | Mounting pin | VDI30 10066228 / VDI40 10682808 |



Before using the machine, make sure that all mounting bores without a tool have been closed with a sealing washer and that the gasket on all tool holders is not damaged.



Any mounting bores not used must be closed with blanking plugs during machining processes.

Disk-type turret

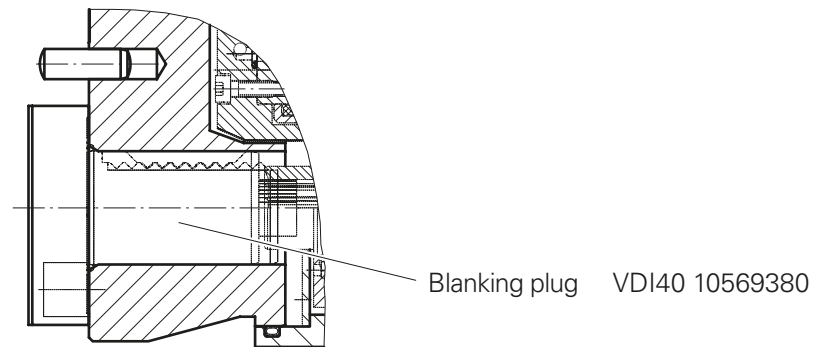

Any mounting bores not used must be closed with blanking plugs during machining processes.

Weight distribution on turret head



Tool holders may have considerably different weights depending on their function and equipment. Therefore, be sure to balance the tool holders evenly around the turret head when tooling.

Collision



After a collision has occurred, check whether the tool carrier has been displaced. If this is the case, the tool carrier must be realigned to ensure that the drive and tool holder gears accurately engage with each other.

Tool change on live tool holders

To avoid damaging or changing the adjustment of the drive train in the turret, tools must **not** be changed on the live tool holders inserted in the turret.

Tools in live tool holders must be changed outside the machine.

Radial turret:

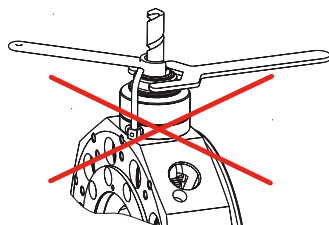

Disk-type turret:

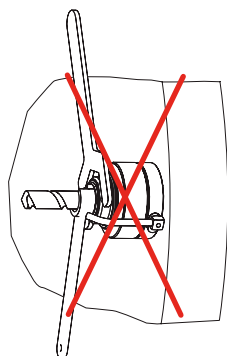

Notes on how to use the diagram when using tool holders

The diagram relates to the output speed **n** of the tool unit. The tool speed can be read directly from the diagram only if the internal speed ratio **i** in the tool holder is 1:1.

For tool holders with an internal speed ratio $i \neq 1$, the output speed **n** of the tool unit to be programmed must be calculated from the required tool speed and the speed ratio **i**. Afterwards, the actual powers or torques can be read off or determined.

Example (at 100% duty cycle):

live tool unit, tool speed $n_{Tool} = 1000$ rpm	
Internal speed ratio i of the tool holder	$i = 4$
Programmed speed n_{prog} for the drive of the unit	$n_{prog} = n_{Tool} * i = 1000 \text{ rpm} * 4 = 4000 \text{ rpm}$
Torque M_{Tool} at the output of the tool holder	Read-out M_d at speed $n_{prog} = 4000 \text{ rpm} = 1.6 \text{ Nm}$ $M_d = M_{Tool} : i$ Formula changed: $M_{Tool} = M_d * i = 1.6 \text{ Nm} * 4 = 6.4 \text{ Nm}$
Power P at the output of the tool holder ≈ Power P at the output of the setup	Read-out at 4000 rpm → $P = 0.67 \text{ kW}$ calculated: $P = 2 * \pi * n_{prog} * M_d$ $P = \frac{2 * \pi * 4000 * 1.6 \text{ Nm}}{60 * 1000} = 0.67 \text{ kW}$

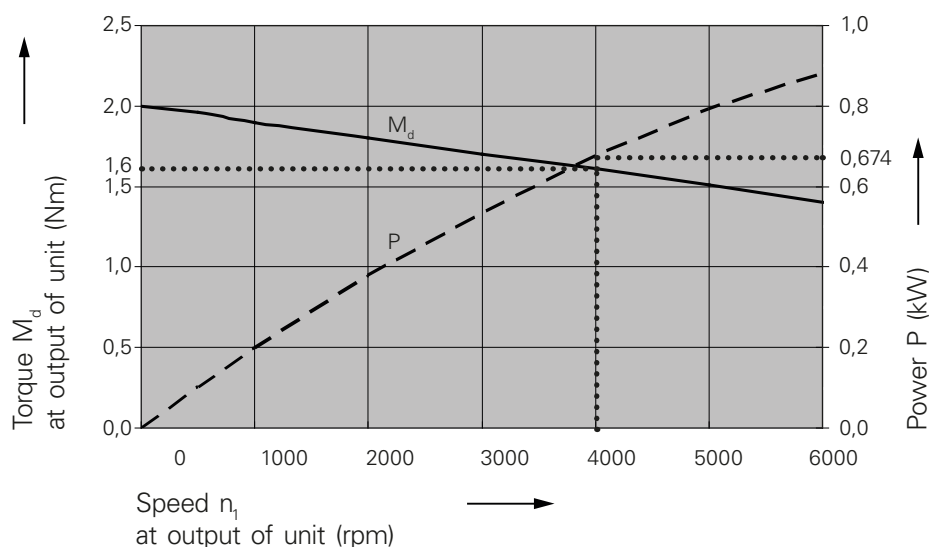

The transmission ratio and the technical data of each tool holder are available in our iXshop at ixshop.index-traub.com

Modular system of INDEX B400, TRAUB TNA400.2

Tool mounting VDI30, Radial turret, 12 stations with W-slots

Tool mounting VDI40, Radial turret, 12 stations with W-slots

Tool mounting VDI40, Disk-type turret, 12 stations

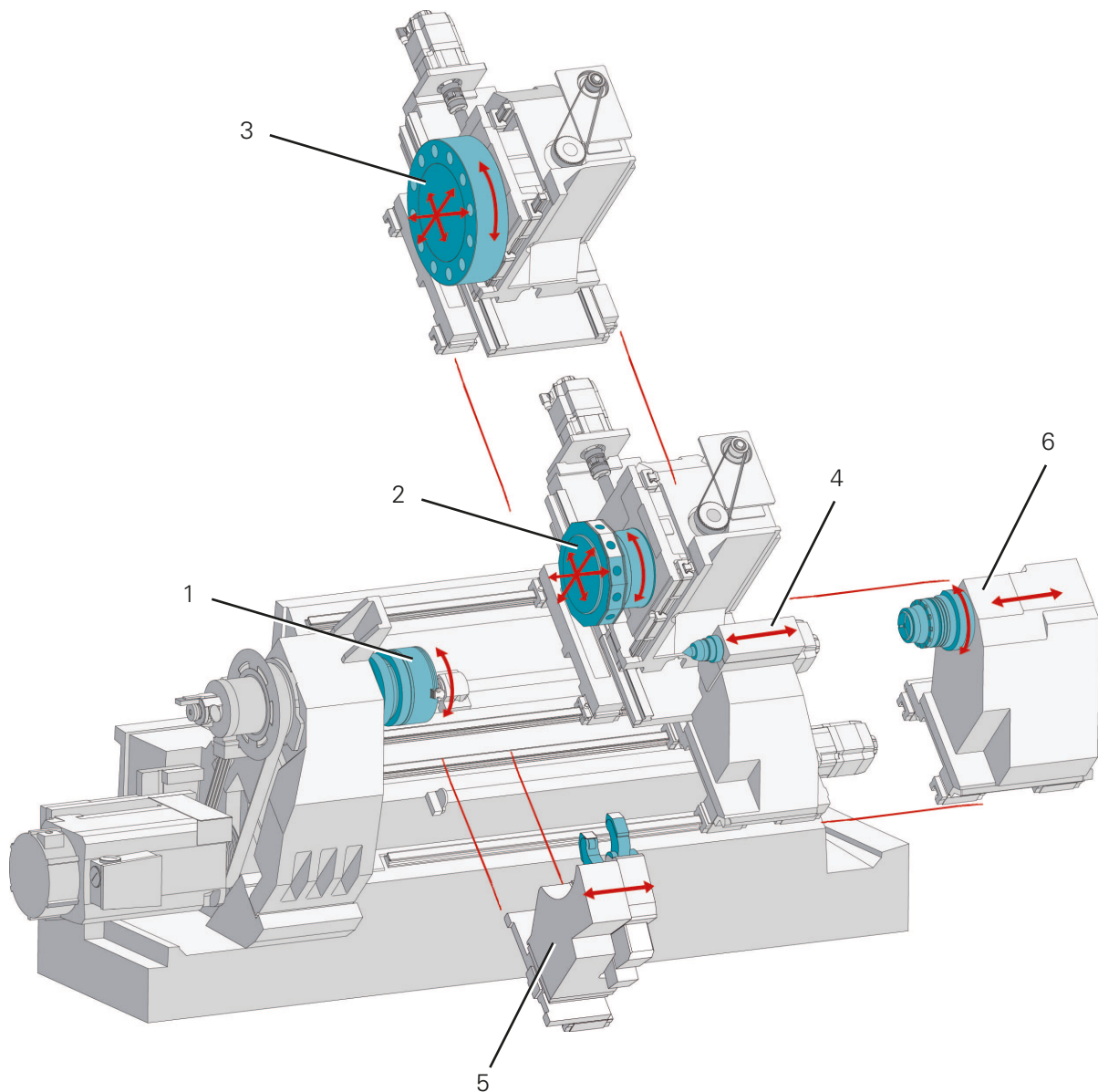

- 1 Main spindle
- 2 Radial turret - XZY
- 3 Disk-type turret - XYZ
- 4 NC tailstock
- 5 Steady rest (option)
- 6 Counter spindle

Work area

INDEX B400 from machine No. 12010119, **TRAUB TNA400.2** from machine No. 12020123

Radial turret VDI30, NC tailstock

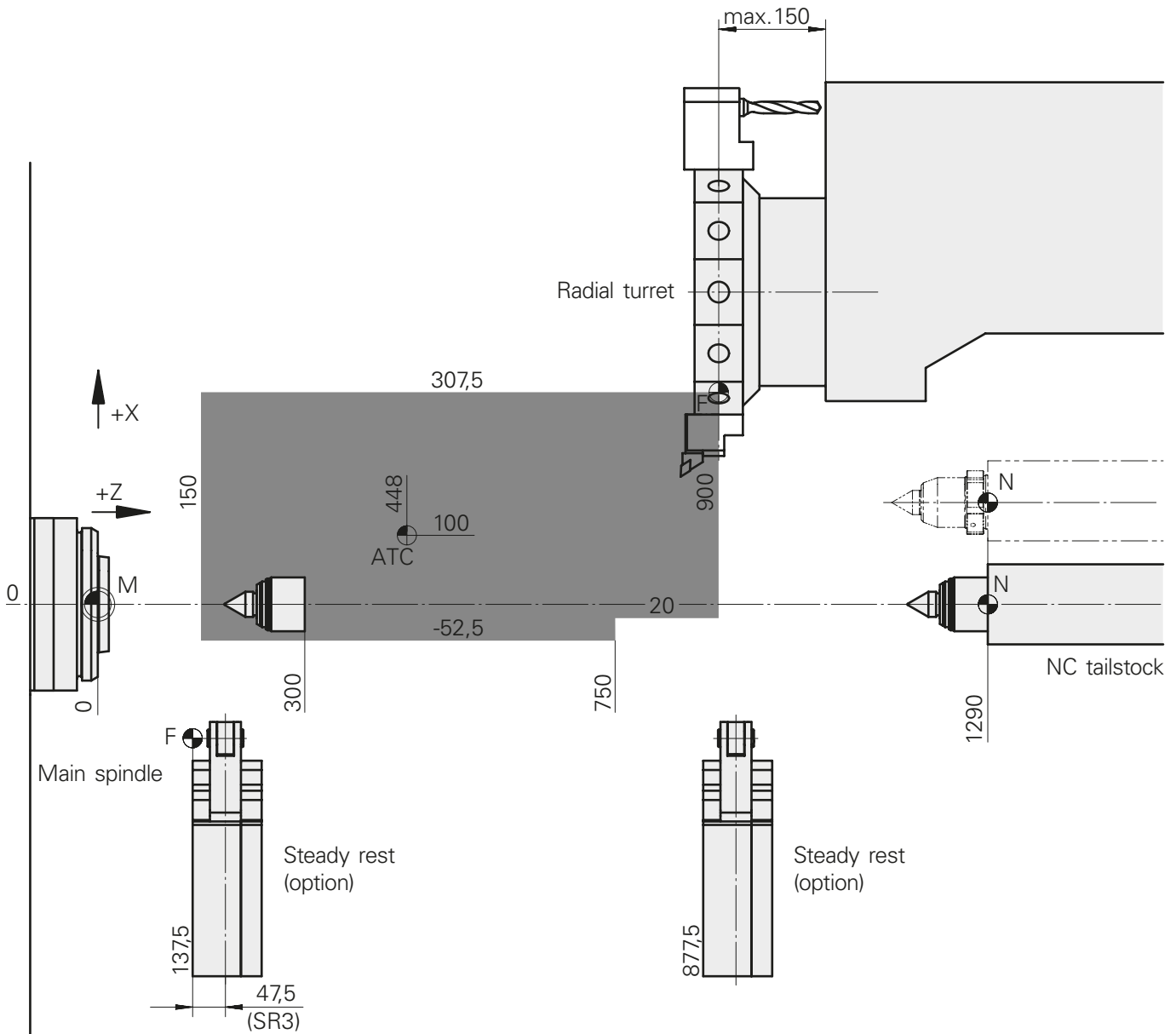

Work area

INDEX B400 from machine No. 12010119, **TRAUB TNA400.2** from machine No. 12020123

Radial turret VDI30, NC tailstock

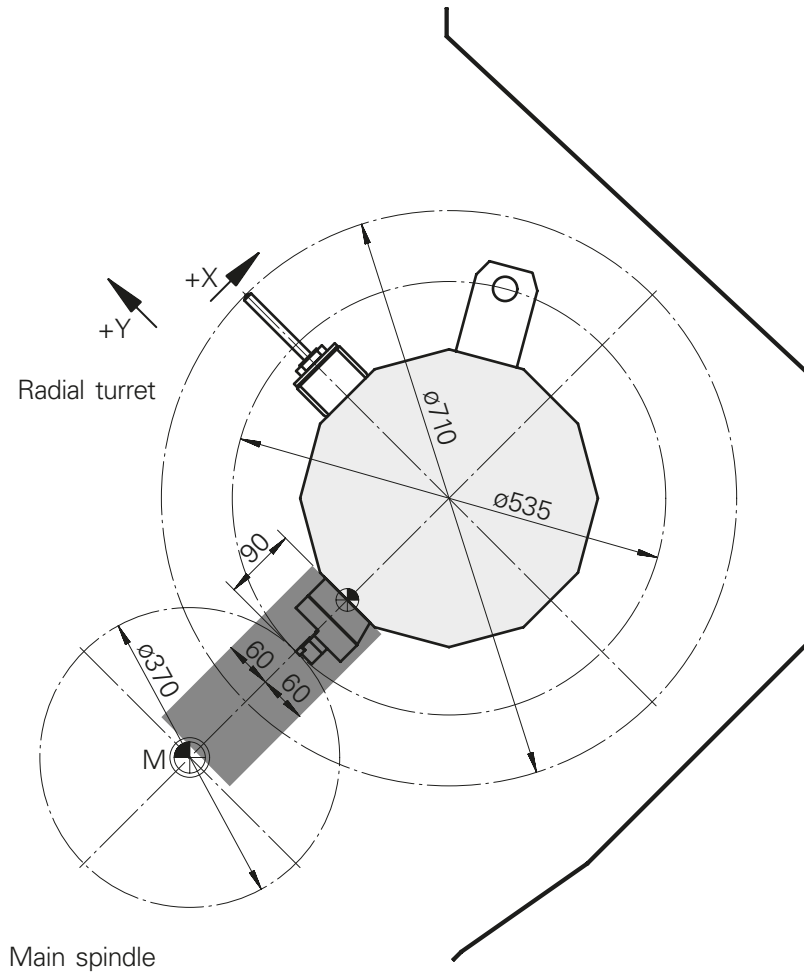

Work area

INDEX B400 from machine No. 12010119, **TRAUB TNA400.2** from machine No. 12020123

Radial turret VDI30, Counter spindle

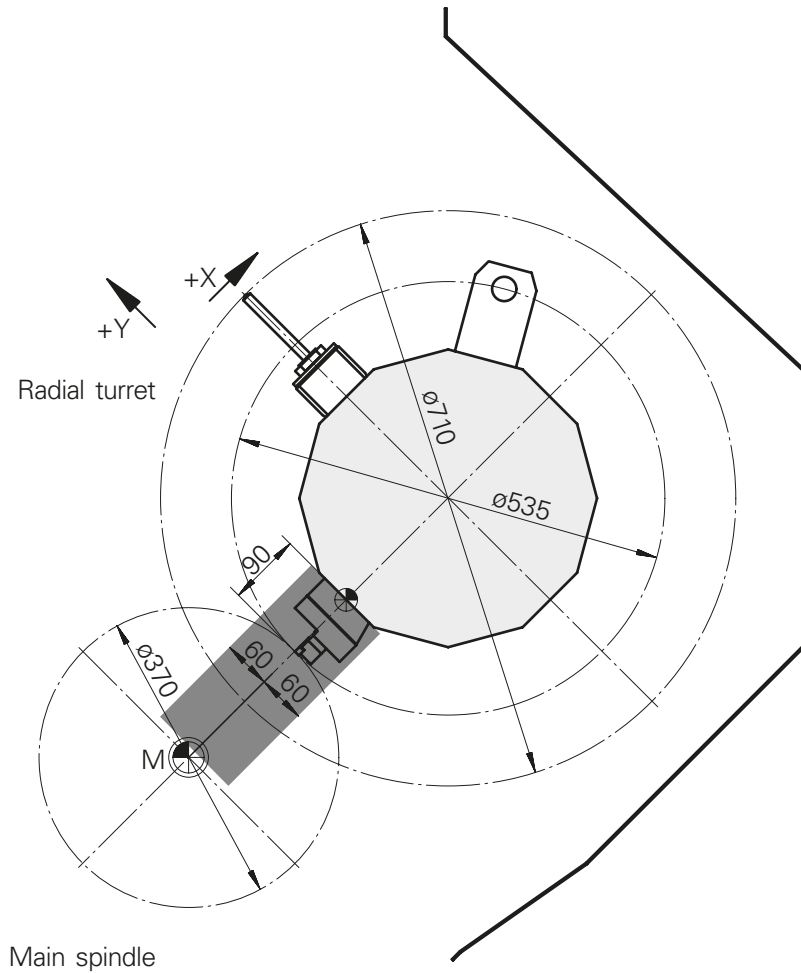

Work area

INDEX B400 from machine No. 12010119, **TRAUB TNA400.2** from machine No. 12020123

Radial turret VDI40, NC tailstock

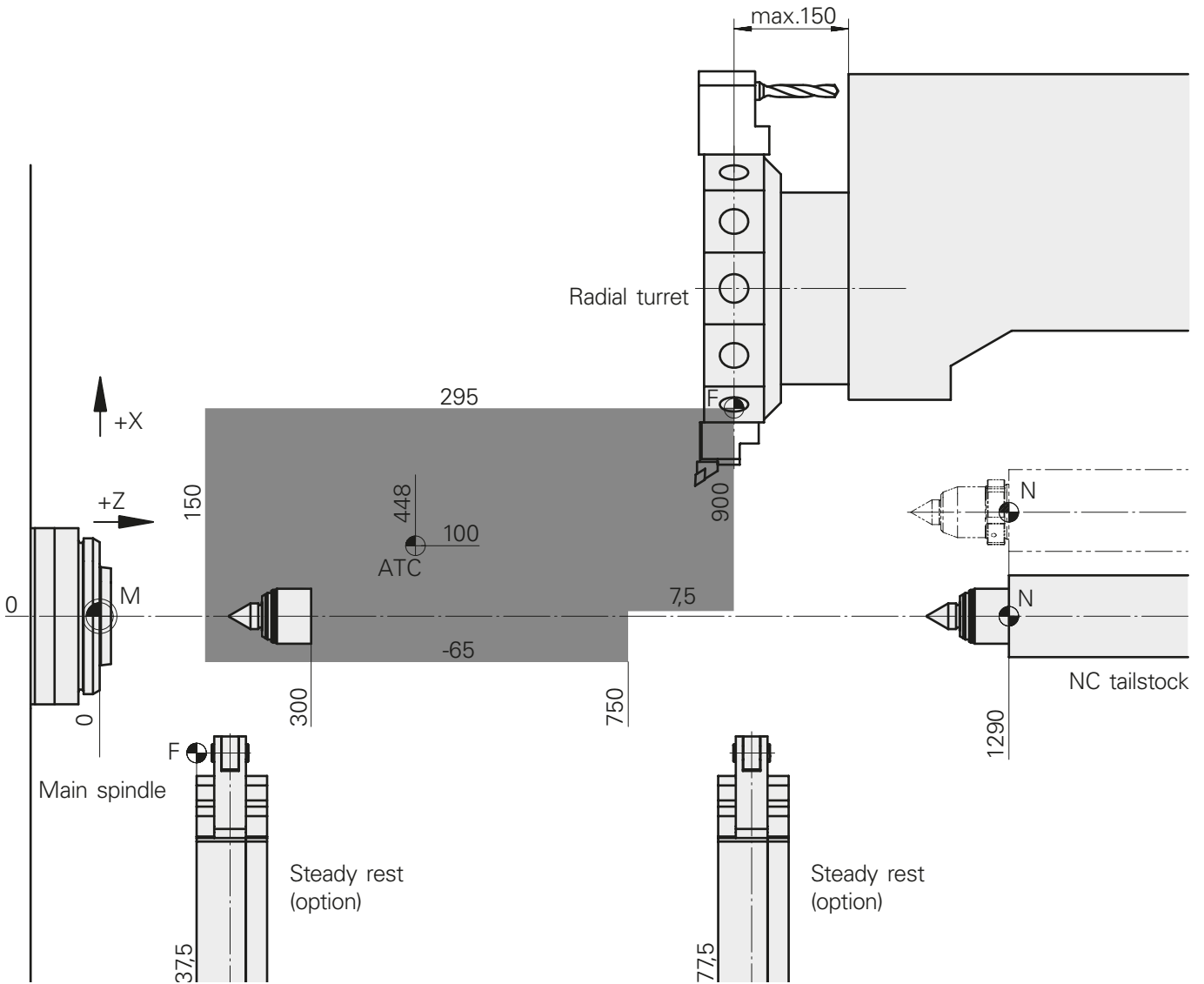

Work area

INDEX B400 from machine No. 12010119, **TRAUB TNA400.2** from machine No. 12020123

Radial turret VDI40, NC tailstock

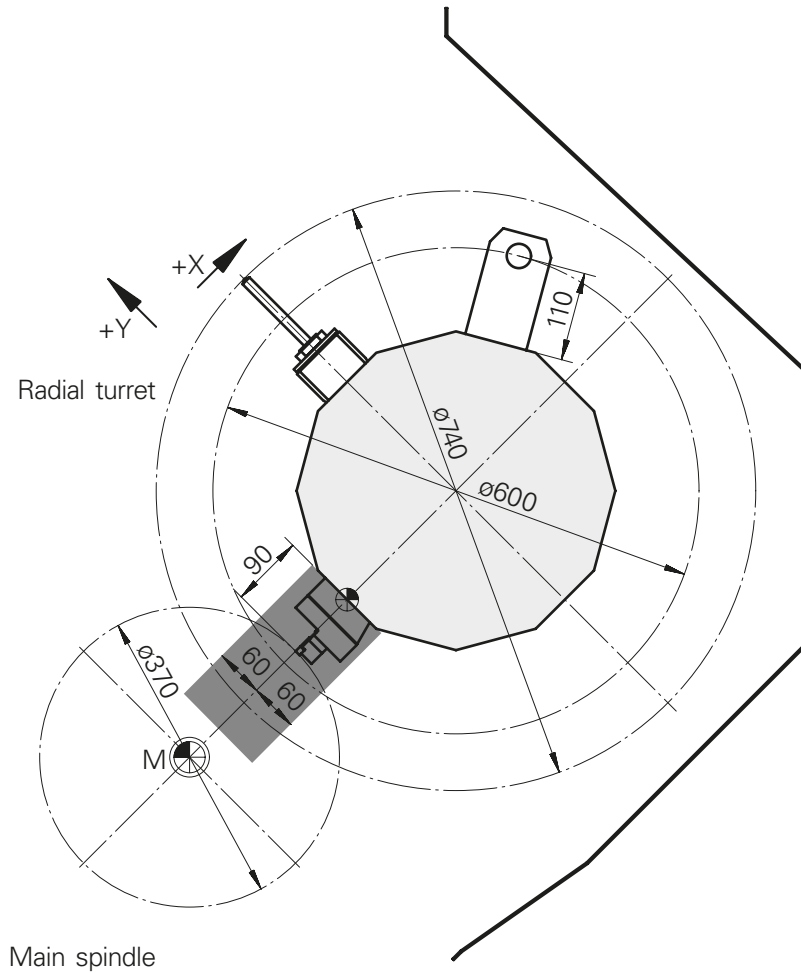

Work area

INDEX B400 from machine No. 12010119, **TRAUB TNA400.2** from machine No. 12020123

Radial turret VDI40, Counter spindle

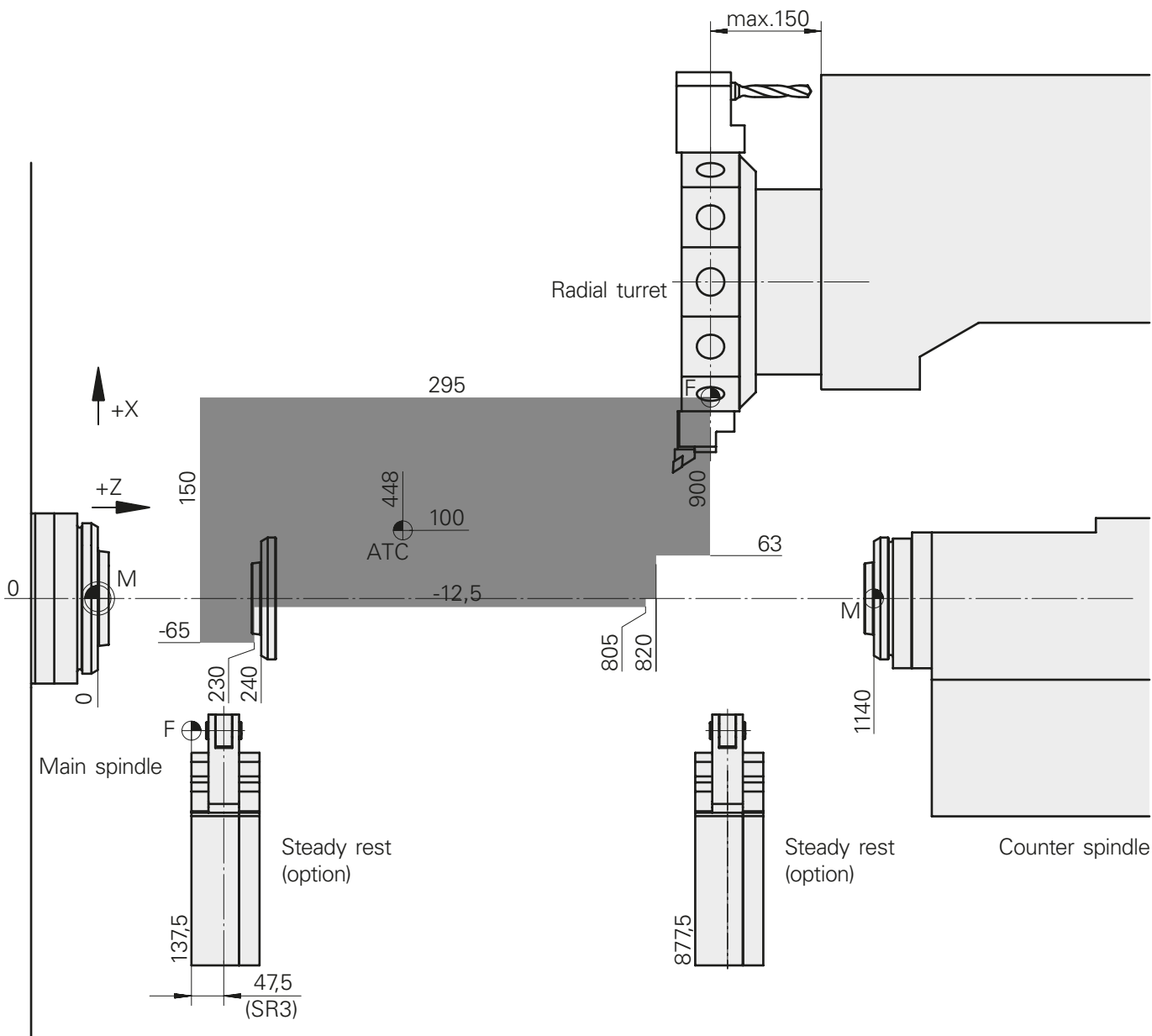

Work area

INDEX B400 from machine No. 12010119, **TRAUB TNA400.2** from machine No. 12020123

Radial turret VDI40, Counter spindle

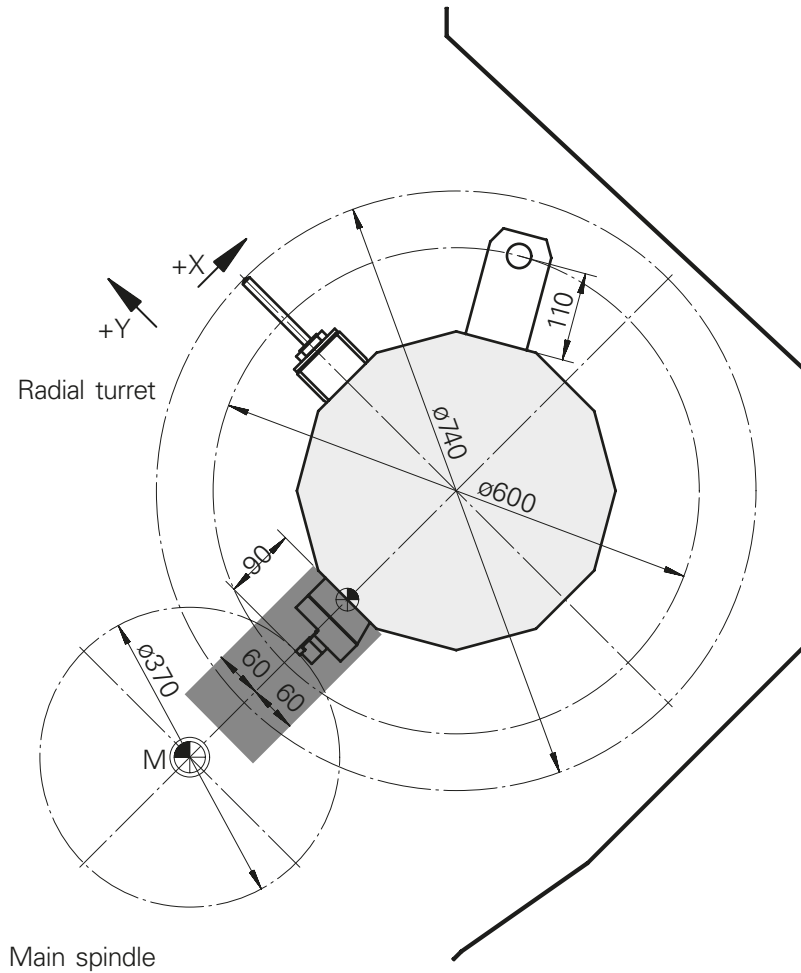

Work area

INDEX B400 from machine No. 12010119, **TRAUB TNA400.2** from machine No. 12020123

Disk-type turret VDI40, NC tailstock

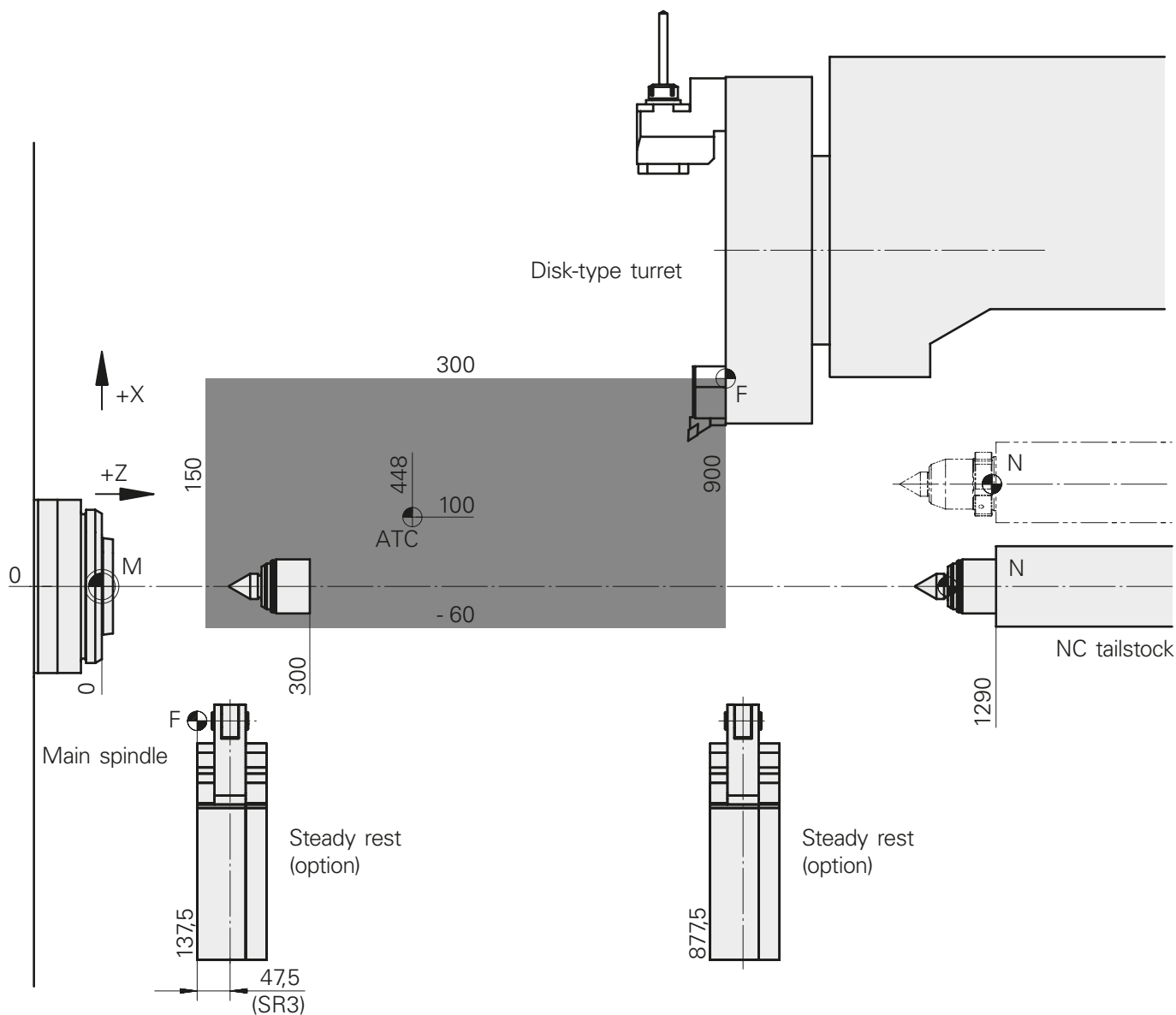

Work area

INDEX B400 from machine No. 12010119, **TRAUB TNA400.2** from machine No. 12020123

Disk-type turret VDI40, NC tailstock

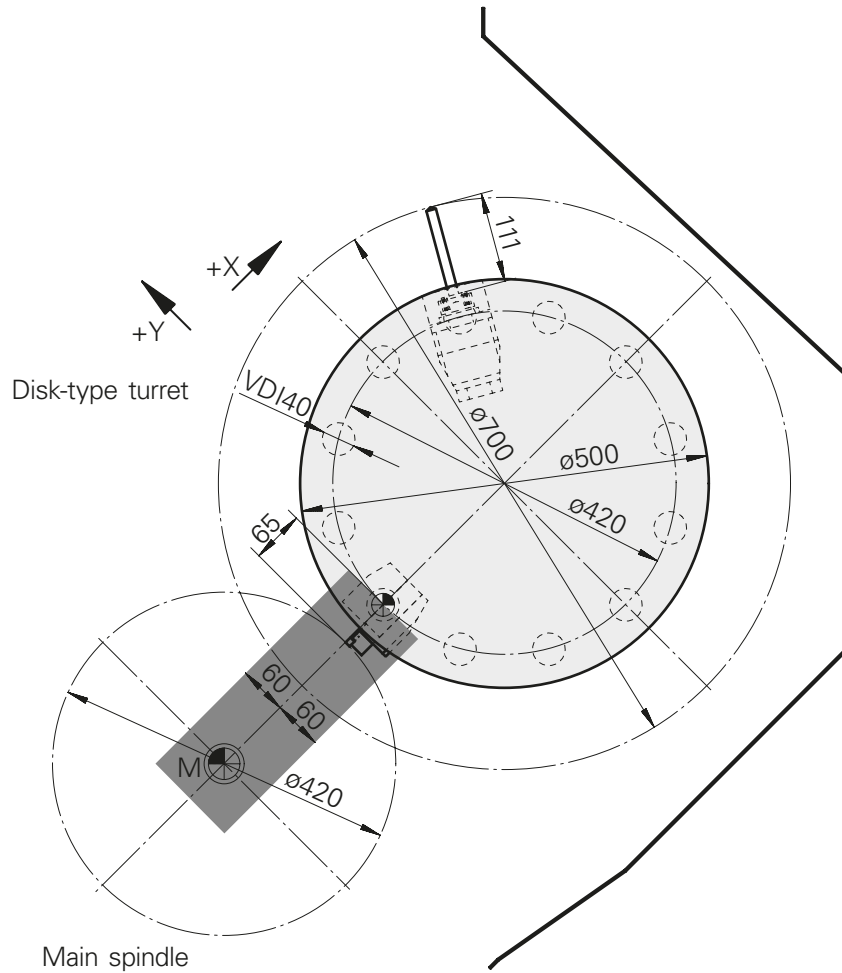

Swivel range INDEX B400, TRAUB TNA400.2

Radial turret with tooling system VDI30

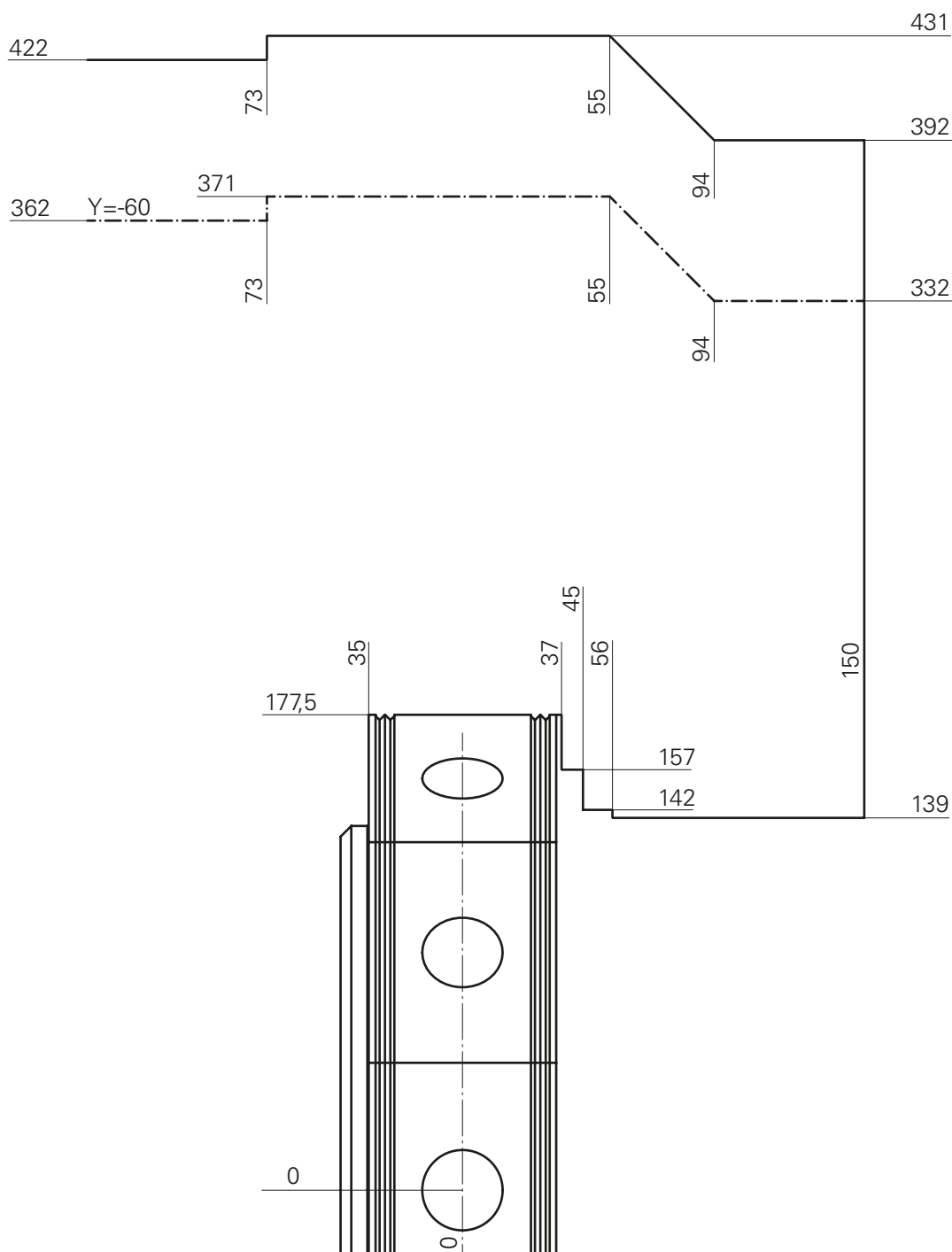

Swivel range INDEX B400, TRAUB TNA400.2

Radial turret with tooling system VDI40

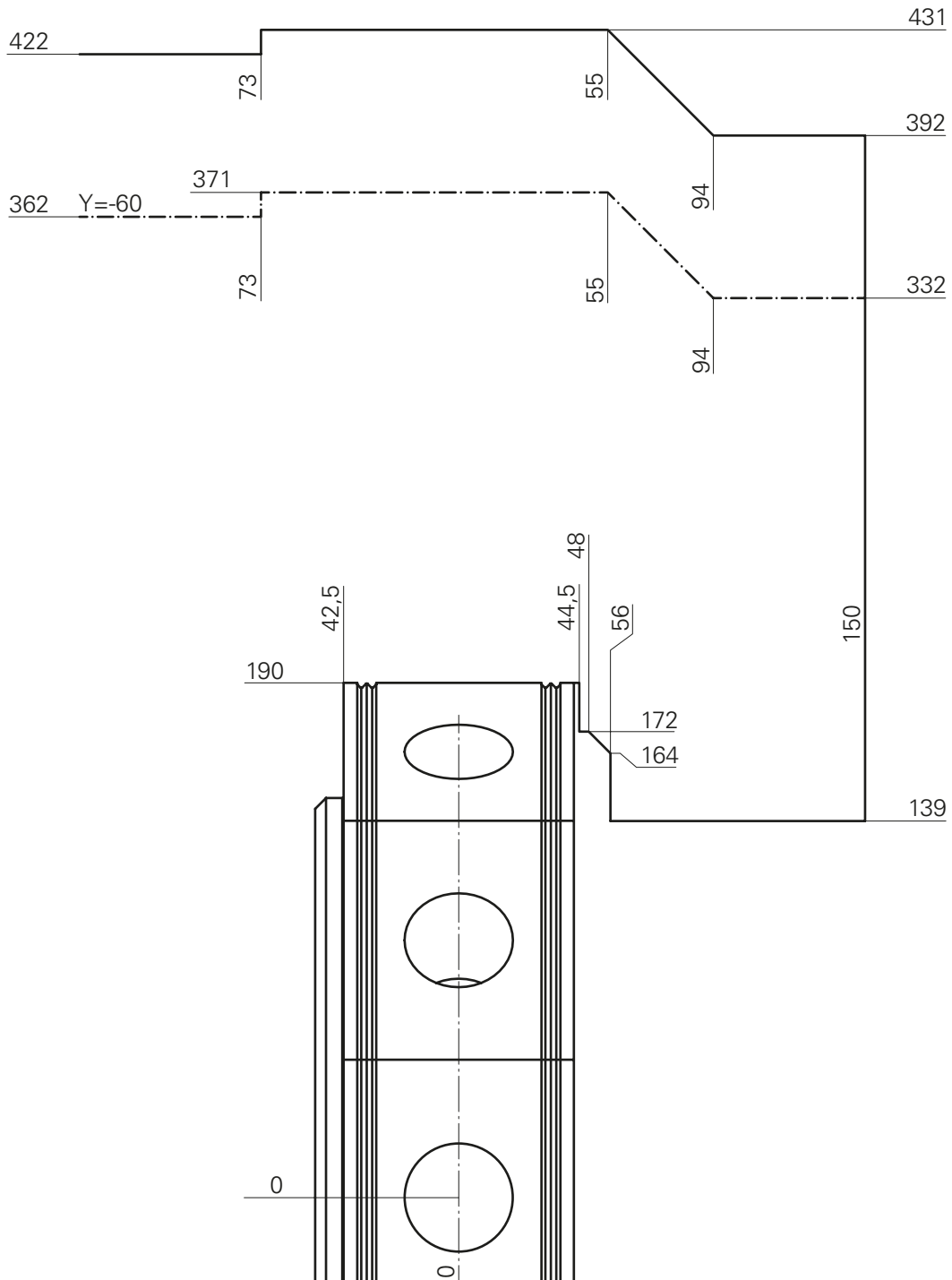

Swivel range INDEX B400, TRAUB TNA400.2

Disk-type turret with tooling system VDI40

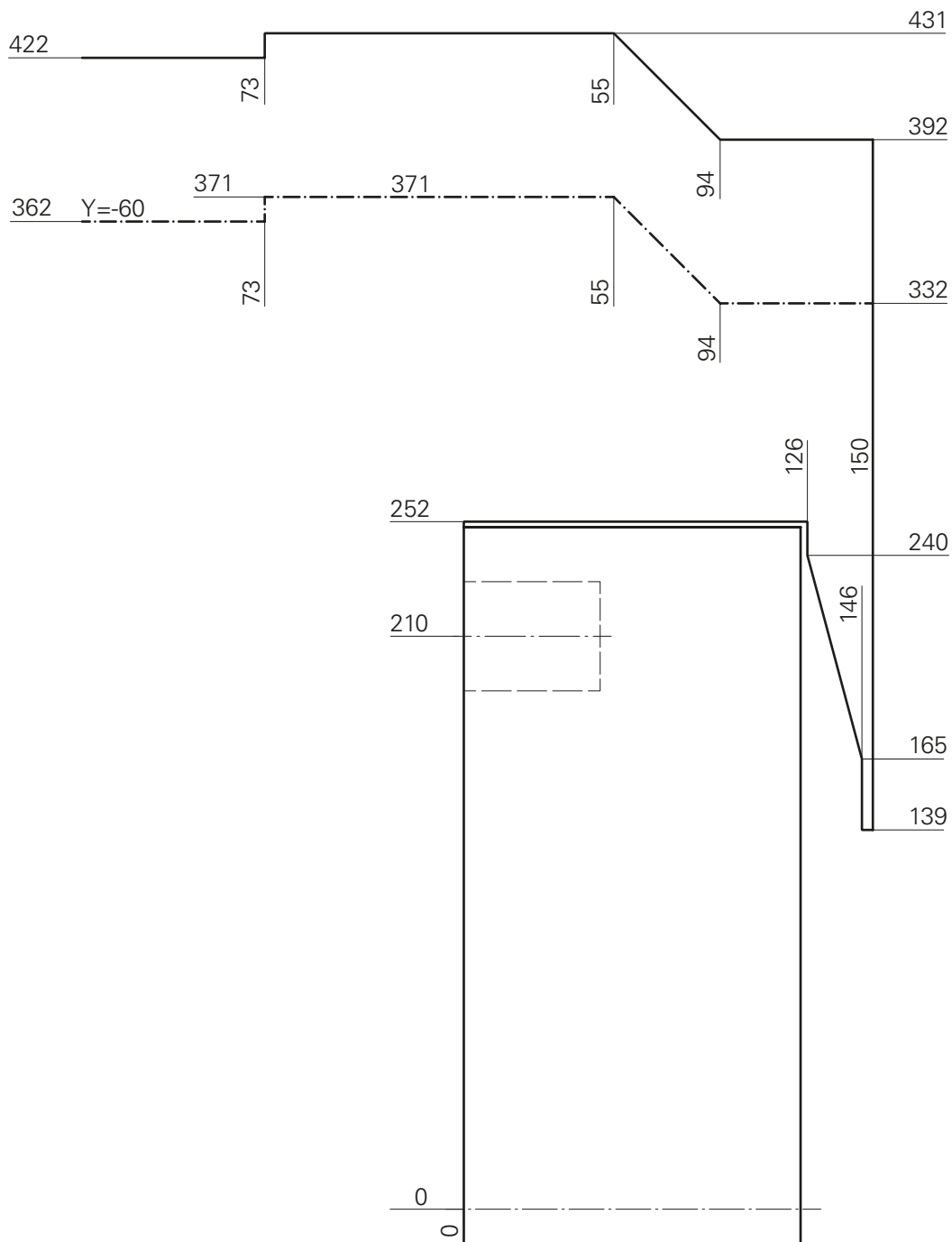

Performance diagram valid for INDEX B400

Live tools VDI30, Radial turret

Speed range 0-6000rpm

i For information on how to use the diagram, see Chapter "Technical Information".

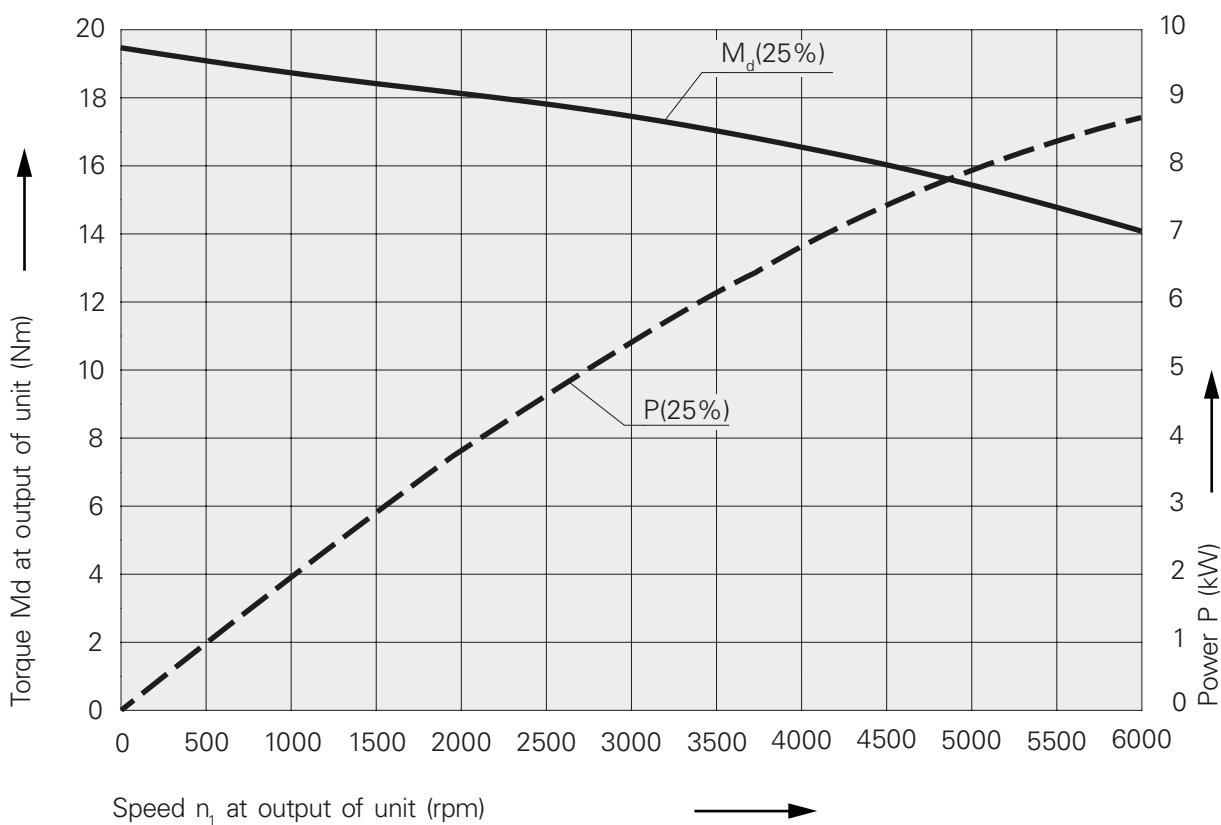

Performance diagram valid for INDEX B400

Live tools VDI40, Radial turret and Disk-type turret

Speed range 0-5400rpm

i For information on how to use the diagram, see Chapter "Technical Information".

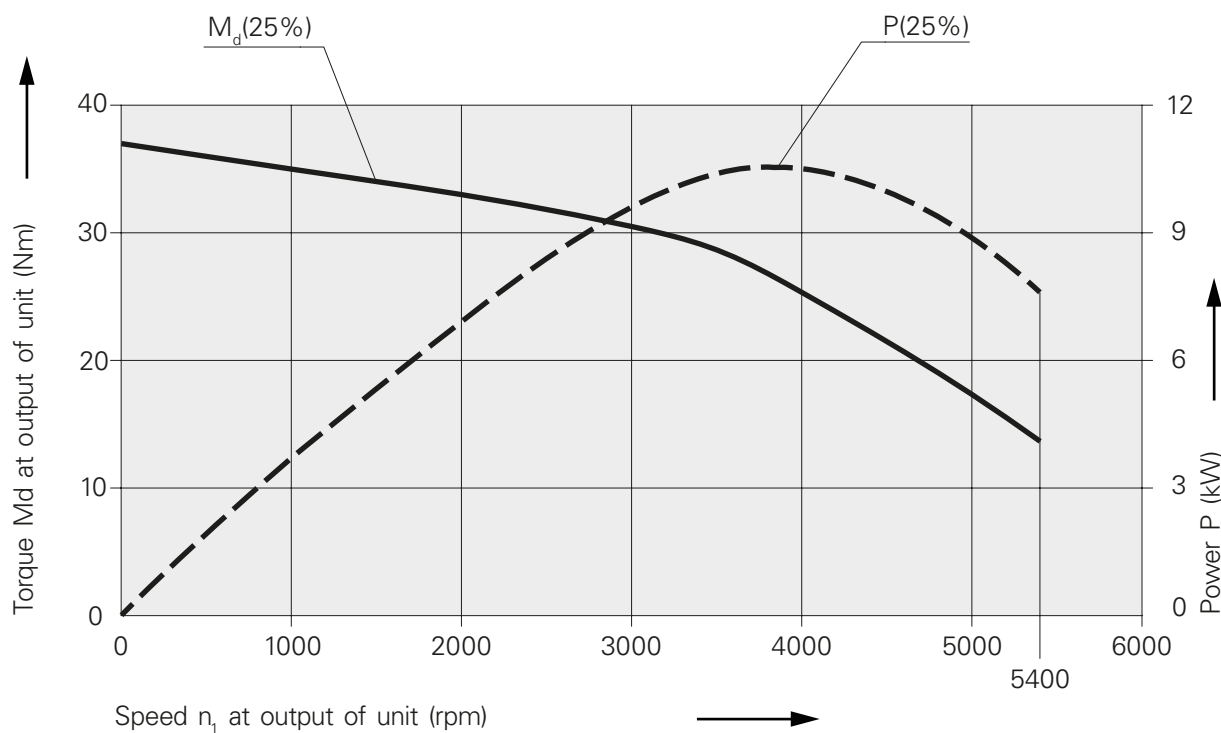

Performance diagram valid for TRAUB TNA400.2

Live tools VDI30, Radial turret

Speed range 0-6000rpm

i For information on how to use the diagram, see Chapter "Technical Information".

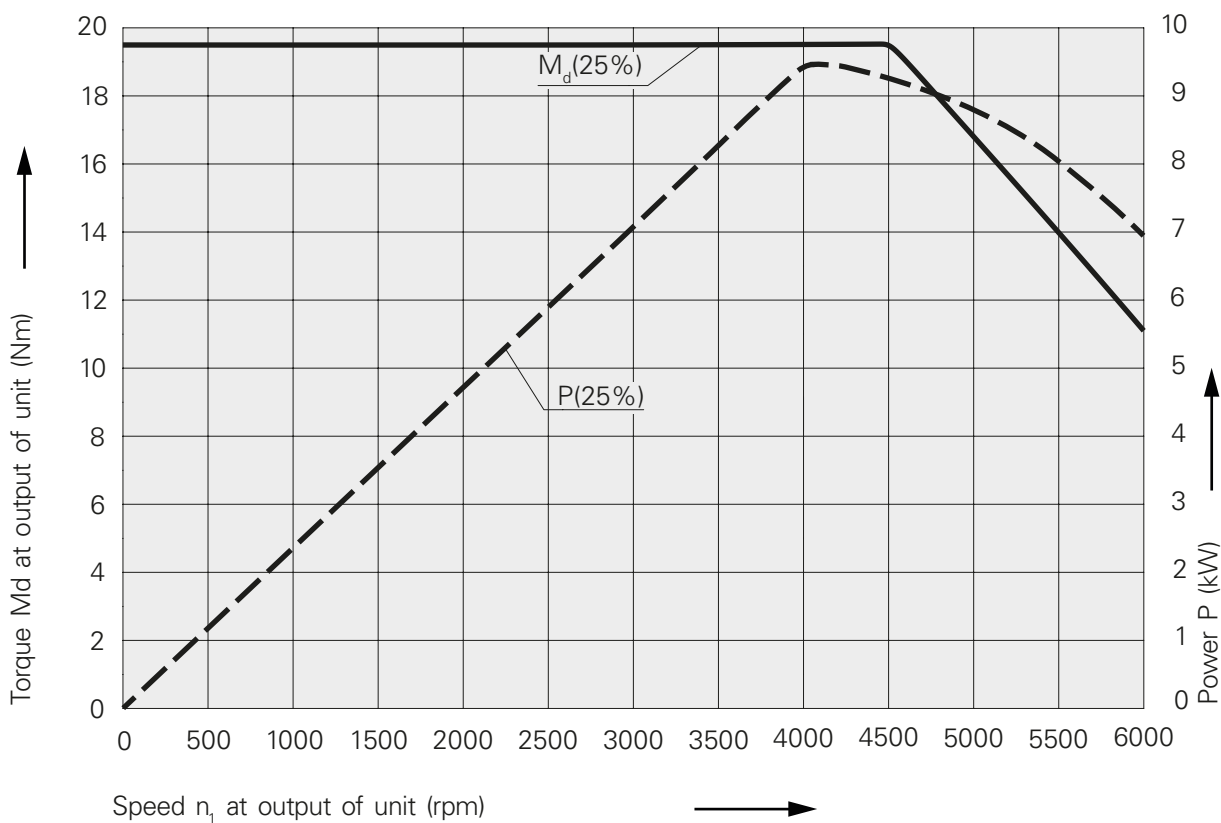

Performance diagram valid for TRAUB TNA400.2

Live tools VDI40, Radial turret and Disk-type turret

Speed range 0-6000rpm

i For information on how to use the diagram, see Chapter "Technical Information".

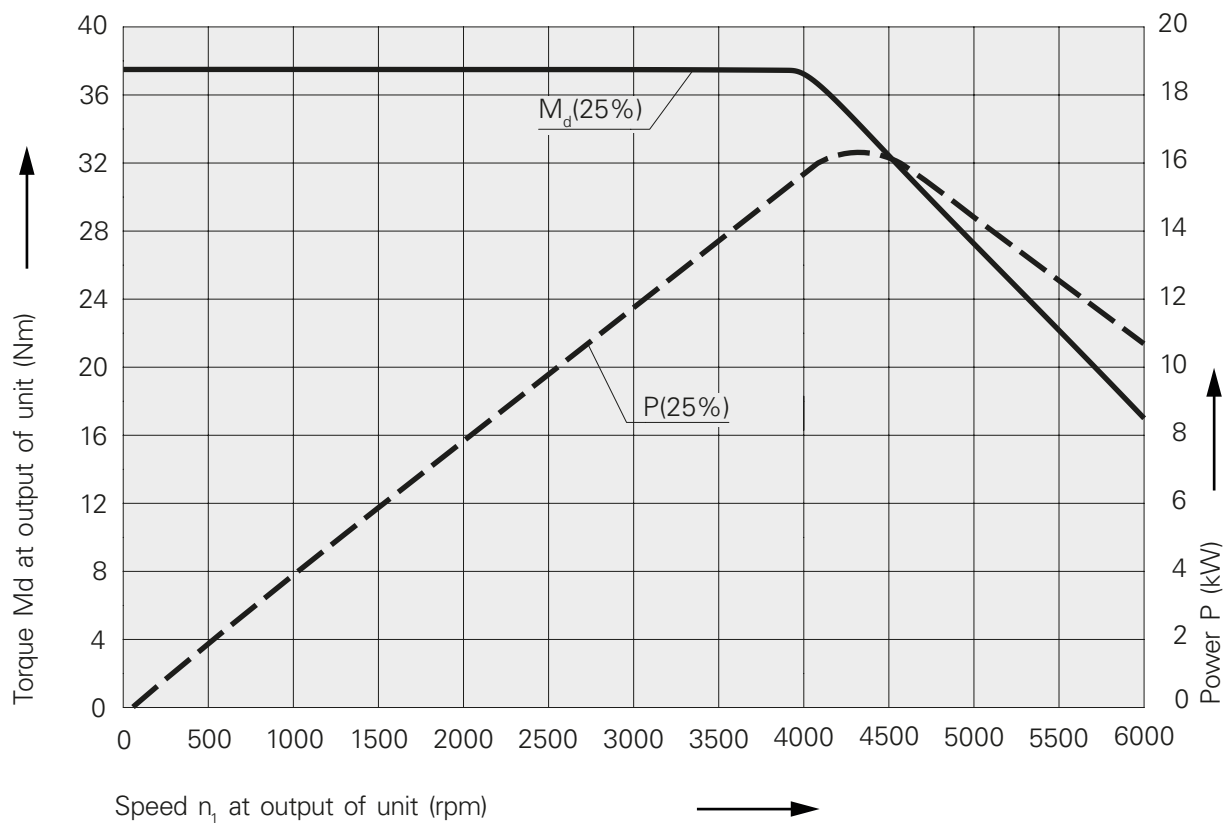



**INDEX-Werke GmbH & Co. KG
Hahn & Tessky**

Plochinger Straße 92
D-73730 Esslingen

Fon +49 711 3191-0
Fax +49 711 3191-587

info@index-werke.de
www.index-werke.de