

Grooving tool and stop holder MS32/MS40

Technical data

Slide system MS	MS32/MS40
Drive	not live
Fixation MS	Dovetail
Cooling	external
Pressure	20 bar
Direction	right-handed run
Mounting	Trapezoid 32x8
X [mm]	65.5 (2.58")
Y [mm]	–
Z [mm]	14.5 (0.57)
INDEX TRAUB products	MS32C • MS32-6.2 • MS40-6 • MS32-6.3

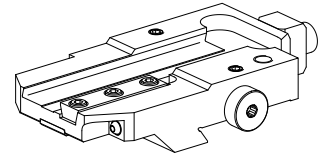

Note

When there is rear end machining with 3 fixed tool holders, mounting occurs in position 6.2!

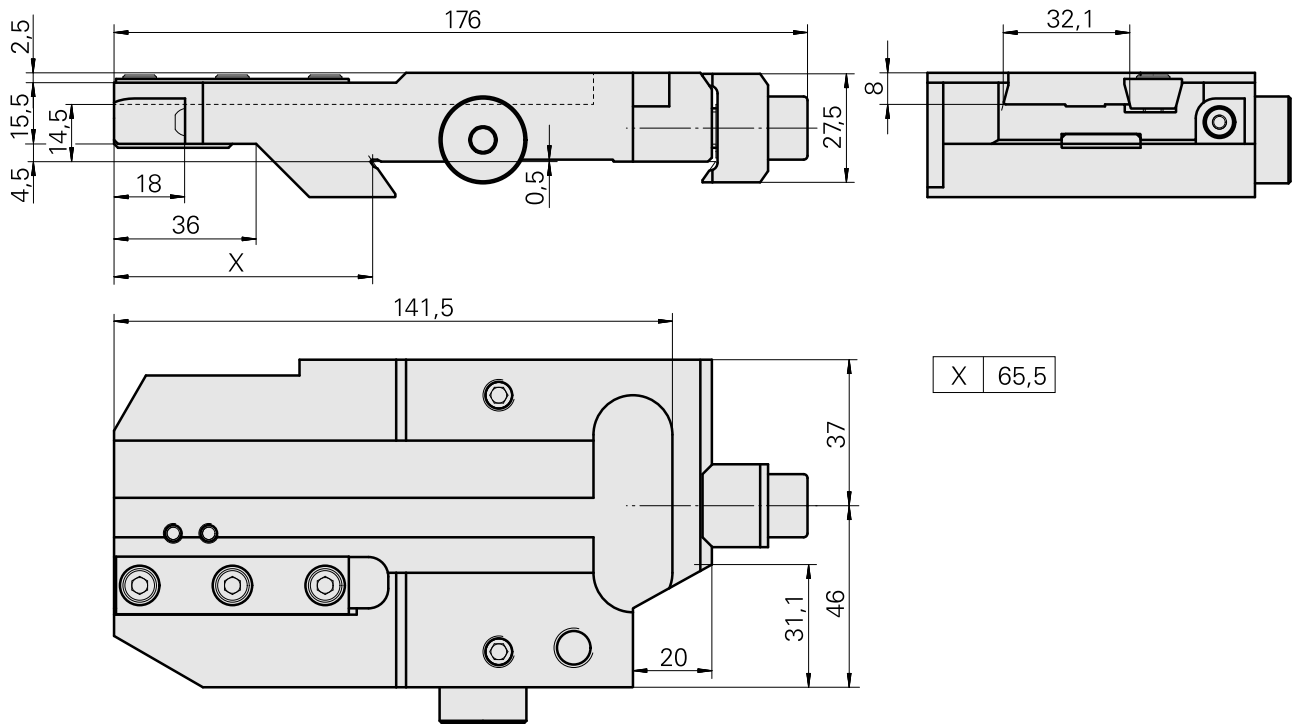

Documents

No downloads available for this product

Accessories

Required for operation

[Ball nozzle 8D/M3,5](#)

Product ID : 10174644

Previous product ID : 474550.0071

Optional accessories

Other accessories

[Stop plate](#)

Product ID : 10217059

Previous product ID : W00019.0064

[Countersunk screw M 4x 8/T20 verzinkt 402314 8](#)

Product ID : 10586100

Previous product ID : 410362.0408
