

Basic holder MS16 cutoff slide, adjustable in Y direction

Technical data

Slide system MS	MS16 cutoff slide
Drive	not live
Fixation MS	W serration
X [mm]	61.9 (2.44")
Y [mm]	–
Z [mm]	52 (2.05)
INDEX TRAUB products	MS16-6 • MS16-6 Plus

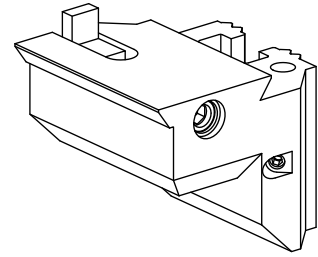

Note

Can be used only in positions 5.0 and 6.0!

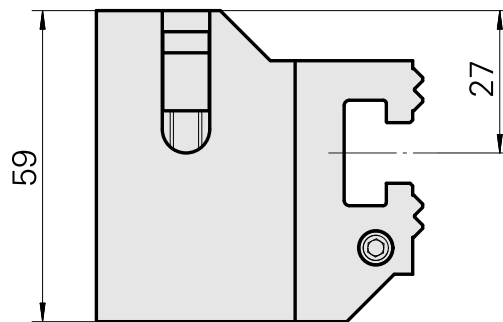
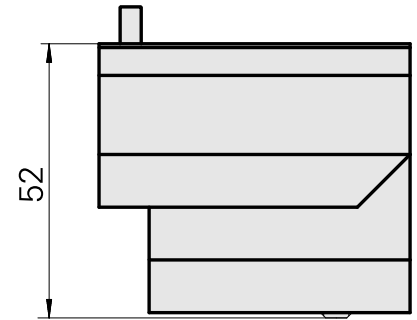
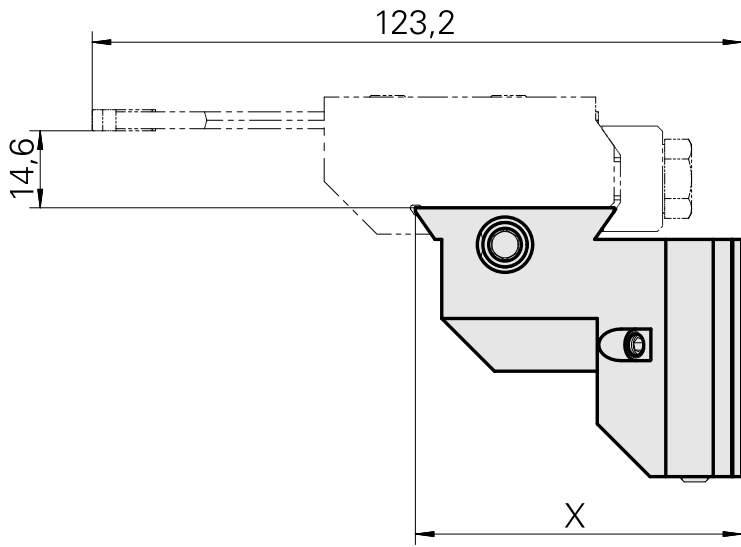

X	61,9
---	------

Documents

No downloads available for this product

Accessories

Optional accessories

MS tool holders

[Grooving tool holding block Trapezoid 26](#)

Product ID : 10099347

Previous product ID : W9991146

Drive not live	Direction left-handed run	Mounting Trapezoid 26x4	X [mm] 55 (2.17")
Y [mm] -	Z [mm] 21 (0.83)	INDEX TRAUB products MS16-6 • MS16-6 Plus	

[Grooving tool holding block 26x4](#)

Product ID : 10972410

Previous product ID : W9991145

Drive not live	Direction right-handed run	Mounting Trapezoid 26x4	X [mm] 55 (2.17")
Y [mm] -	Z [mm] 21 (0.83)	INDEX TRAUB products MS16-6 • MS16-6 Plus	