

## Boring head for DN.. 1506..

### Technical data

<b>Mounting</b>	for DN.. 1506..
<b>Cooling</b>	internal
<b>Pressure</b>	50 bar
<b>X [mm]</b>	45 (1.77")
<b>Z [mm]</b>	22 (0.87)
<b>INDEX TRAUB products</b>	G220.3 • R200 • TNX65/42 • TNX220.3

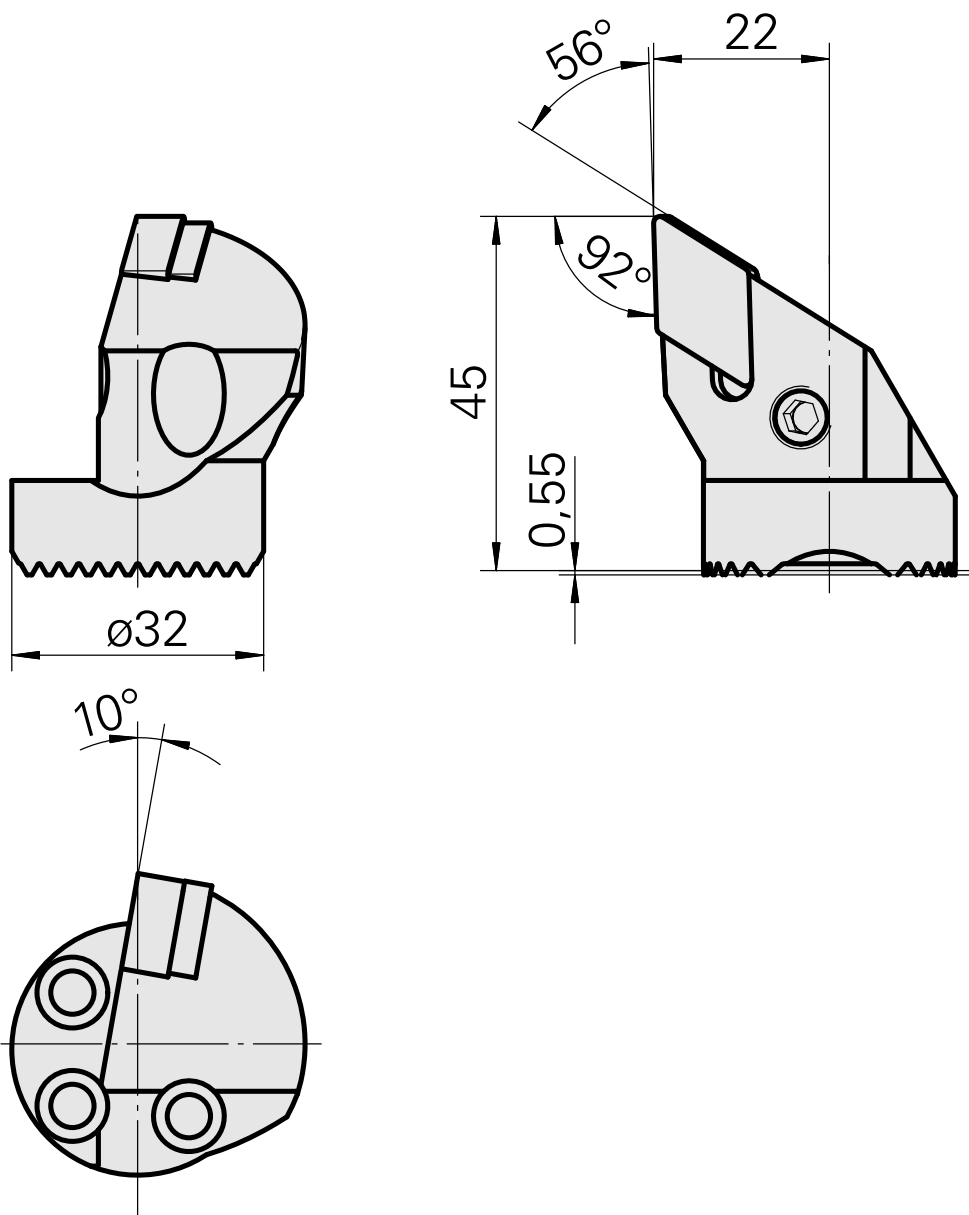

10684981  
W9990283

**INDEX**

---

## Documents

No downloads available for this product

## Accessories

Required for operation

[Chucking parts 315004](#)

Product ID : 10023015

Previous product ID : W00014.0022

---