

Knurling tool holding block D6 (0.24 ")

Technical data

Drive	not live
Fixation VDI	none
Mounting	D6
X [mm]	38 (1.50")
Y [mm]	-
Z [mm]	20 (0.79)
INDEX TRAUB products	G160 • G300 • ABC • C100 • C200 • G200 • G200.2 • G220 • G250 • ABC.2

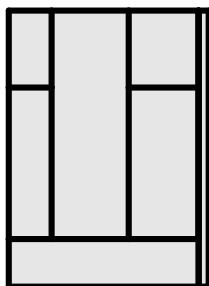
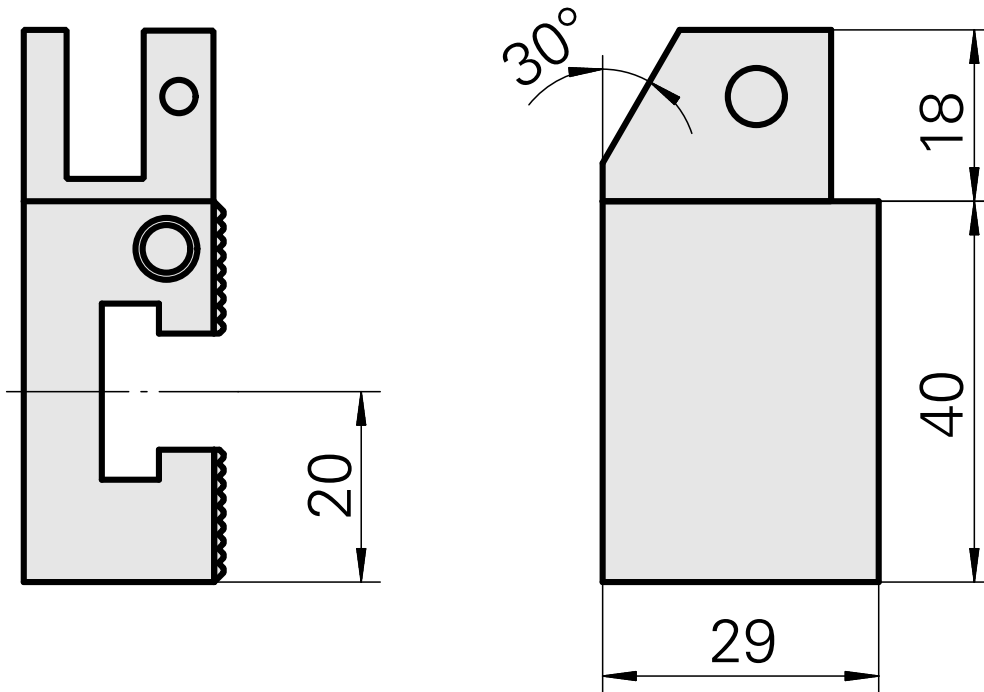
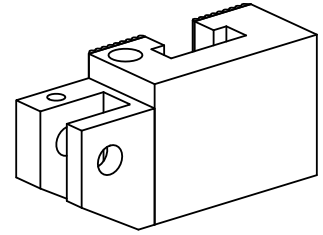

10442459
W9990154

INDEX

Documents

No downloads available for this product