

镗刀头

技术特点

冷却

内冷

压力

50 bar

X [mm]

26

Z [mm]

35

INDEX TRAUB产品

G220 · G420 · G520 · G320.2 ·
G220.3 · TNX220.3

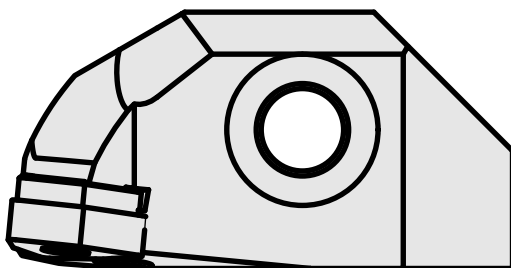
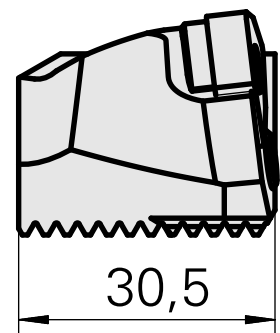
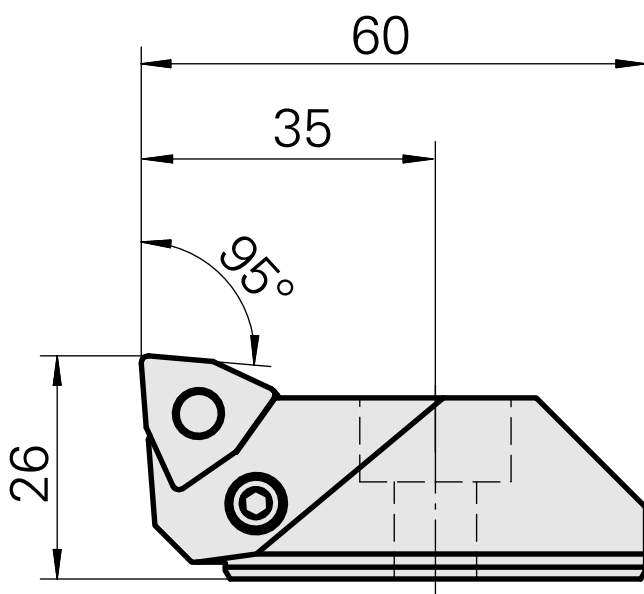
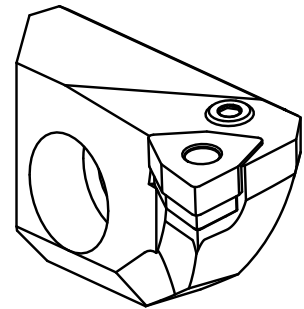

文件

没有针对此产品的任何下载