

## 铣刀架 HSK 25 C 铣削轴 D10

### 技术特点

刀柄 <b>HSK</b>	HSK 25
类型 <b>HSK</b>	C
夹具	铣削轴 D10
冷却	内冷
压力	40 bar
<b>X [mm]</b>	19
<b>INDEX TRAUB</b> 产品	MS22-6 • MS22-8 • MS16-6

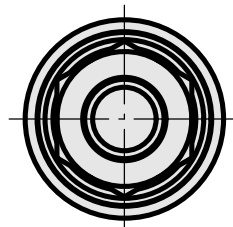
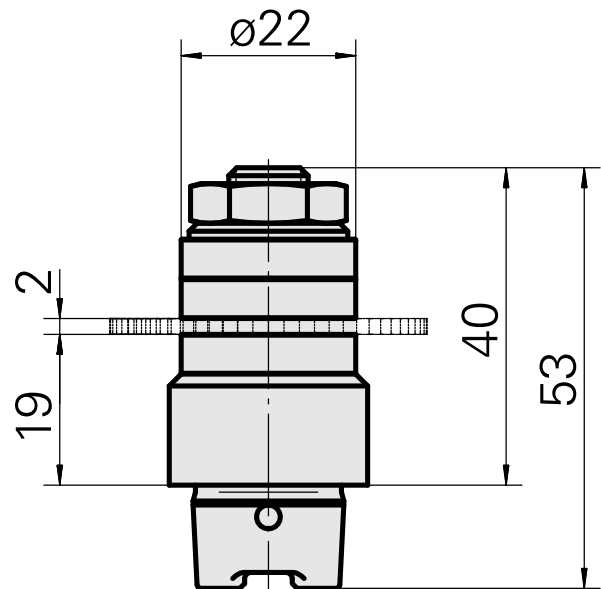
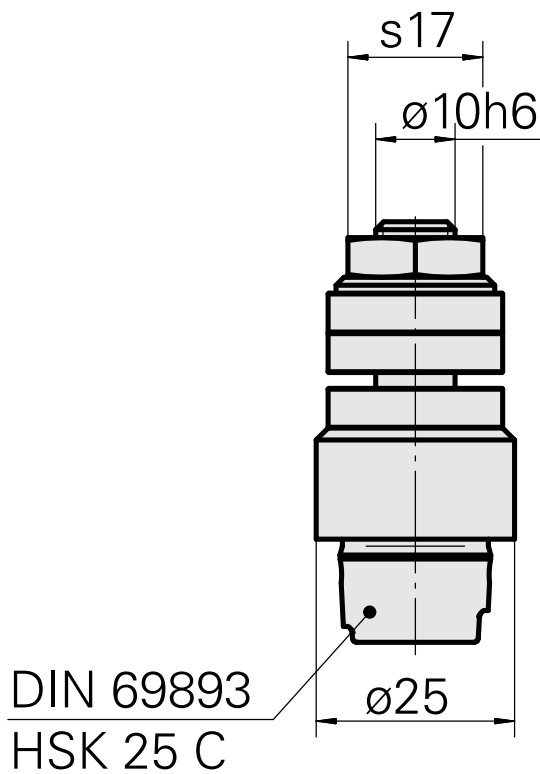
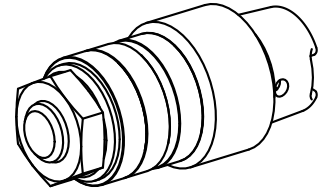

## 文件

没有针对此产品的任何下载