

## Bar stop VDI 20, live

### Technical data

Shank VDI	VDI 20
Drive	not live
Fixation VDI	none
reversible 180°	yes
Data carrier	check tool station bore
X [mm]	64 (2.52")
Y [mm]	–
Z [mm]	0 ()
INDEX TRAUB products	C100

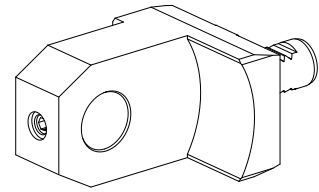

### Note

Bar stop D58 10900227 or D85 10452051 must be ordered separately.

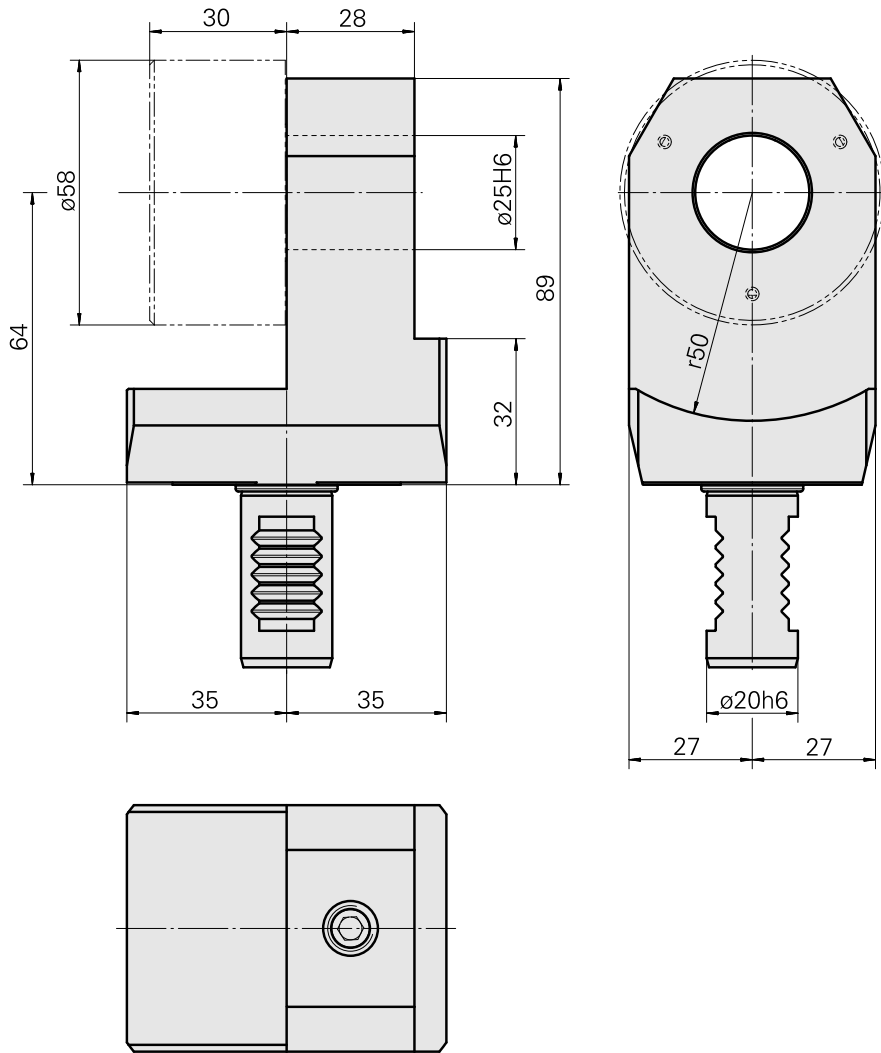

## Documents

No downloads available for this product

## Accessories

### Optional accessories

#### Tool holders with VDI shank

#### [Bar stop D58 \(2.28 "\), live](#)

Product ID : 10900227

Previous product ID : W9990159

Drive not live	Mounting D58	X [mm] -	Y [mm] -
Z [mm] 30 (1.18)	INDEX TRAUB products C42/65 • G160 • ABC • B400 • C100 • C200 • G200 • G200.2 • G220 • TNX65/42 • TNA400.2 • G420 • B500 • TNA500.2 • G400.2 • G500 • G520 • ABC.2 • G300.2 • G320.2 • G200.3 • G220.3 • TNX200.3 • TNX220.3 • B400.3 • B500.3 • TNA400.3 • TNA500.3		

Bar stop D85 (3.35 "), live

Product ID : 10452051

Previous product ID : W9990160

Drive	Mounting	X [mm]	Y [mm]
not live	D85	-	-
Z [mm] 30 (1.18)	INDEX TRAUB products C42/65 • G160 • ABC • B400 • C100 • C200 • G200 • G200.2 • G220 • G250 • TNX65/42 • TNA400.2 • B500 • TNA500.2 • G420 • G400.2 • G500 • G520 • ABC.2 • G300.2 • G320.2 • B400.3 • B500.3 • TNA400.3 • TNA500.3		